

MWI 122.2 X

12NC: F102857

GTIN (EAN) code: 8050147028575

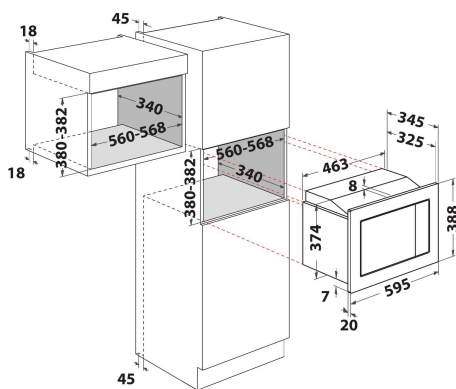

MAIN FEATURES

Product group	Microwave
Commercial code	MWI 122.2 X
Main colour of product	ИНОКС
Type of micro-wave oven	MW+Grill function
Construction type	Built-in
Type of control	Electronic
Type of control settings	Digit
Additional cooking method Grill	Yes
Хрупкаво	No
Steam	No
Additional cooking method Fan cooking	No
Clock	Yes
Automatic programmes	Yes
Height of the product	388
Width of the product	594
Depth of the product	344
Minimum niche height	378
Minimum niche width	560
Niche depth	340
Net weight (kg)	15
Cavity capacity (l)	20
Turntable	Yes
Turntable diameter (mm)	245
Integrated Cleaning system	No

TECHNICAL FEATURES

Current (A)	16
Voltage (V)	230
Frequency (Hz)	50
Length of Electrical Supply Cord (cm)	100
Plug type	Schuko
Timer	Yes
Grill power (W)	1000
Type of grill	Heating element
Cavity material	Stainless steel
Interior light	Yes
Additional cooking method Grill	Yes
Position of interior lights of the cavity	Ceiling

ENERGY LABEL

6th Sense / Dynamic Intelligence	No
Number of power levels	5
Maximum micro-wave power (W)	800
Размразяване на хляб	No
Размразяване	No
Старт	No