

W9 MD260 BSS

12NC: 859991569230

GTIN (EAN) code: 8003437396311

Whirlpool

SENSING THE DIFFERENCE

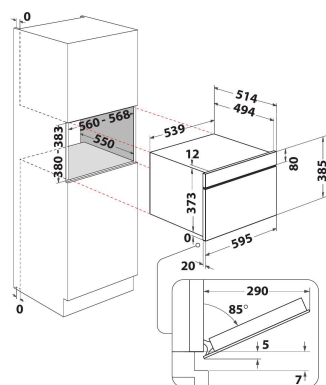

MAIN FEATURES

Product group	Mikrovalna pećnica
Commercial code	W9 MD260 BSS
Main colour of product	Black Steel
Type of micro-wave oven	MW-Combi
Construction type	Ugradbeni
Type of control	Electronic
Type of control settings	LCD
Additional cooking method Grill	Yes
Funkcija Crisp	Yes
Steam	Yes
Additional cooking method Fan cooking	Yes
Clock	Yes
Automatic programmes	Yes
Height of the product	385
Width of the product	595
Depth of the product	514
Minimum niche height	380
Minimum niche width	556
Niche depth	550
Net weight (kg)	27
Ljubičasta sa bisernim odsjajem	31
Turntable	Yes
Turntable diameter (mm)	325
Integrated Cleaning system	Ne

TECHNICAL FEATURES

Current (A)	10
Voltage (V)	230
Frequency (Hz)	50
Length of Electrical Supply Cord (cm)	135
Plug type	Schuko
Timer	Yes
Grill power (W)	800
Type of grill	Quartz
Funkcija Crisp	Stainless steel
Interior light	Yes
Additional cooking method Grill	Yes
Position of interior lights of the cavity	-

ENERGY LABEL

6th Sense / Dynamic Intelligence	Tehnologija 6.ČULO
Number of power levels	7
Maximum micro-wave power (W)	1000
Funkcija Bread defrost	Yes
Funkcija Jet defrost	Yes
Funkcija Jet Start	Yes