

AKT 8210/NE

12NC: 859991015400

GTIN (EAN) code: 8003437829550

Whirlpool

SENSING THE DIFFERENCE

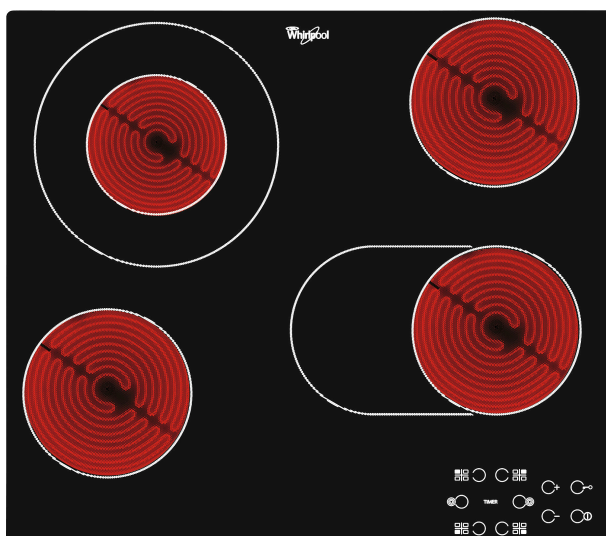

Whirlpool hob - AKT 8210/NE

This Whirlpool Hob features: electric power supply.

Front Controls

Complete control over your cooking. Easily accessible and genuinely intuitive, the controls are conveniently positioned on the front panel of your hob, providing a frictionless cooking experience.

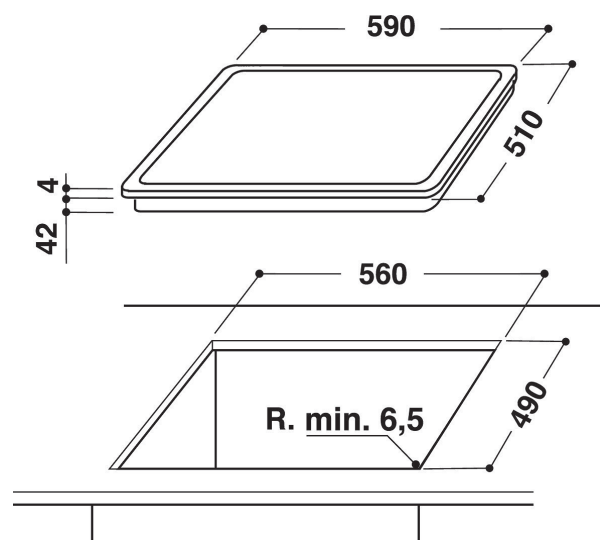

- Residual heat indicator
- Child lock
- On/Off Switch
- 60 cm hob
- Timer
- Black Glass Hob
- 4 Radiant cooking zones
- 4 Plate on Indicator
- Power on indicator
- 4 Cooking zones: 1 Radiant 1200 W, 1 Radiant 750/2100 W, 1 Radiant 1200 W, and 1 Radiant 1000/1800 W
- Frameless
- Dimensions HxWxD: 46x580x510 mm
- Niche dimensions HxWxD: 42x560x490 mm
- Electrical Connection Rating: 6300 W
- Voltage: 230 V
- Front left zone: 145 mm \varnothing , 1200 W

AKT 8210/NE

12NC: 859991015400

GTIN (EAN) code: 8003437829550

Whirlpool

SENSING THE DIFFERENCE

MAIN FEATURES

Product group	Hob
Construction type	Built-in
Type of control	Electronic
Type of control settings	-
Number of gas burners	0
Number of electric cooking zones	4
Number of electric plates	0
Number of radiant plates	4
Number of halogen plates	0
Number of induction plates	0
Number of electric warming zones	0
Location of control panel	Front
Basic surface material	Glass
Main colour of product	Black
Electrical connection rating (W)	6300
Gas connection rating (W)	0
Current (A)	27,8
Voltage (V)	230
Frequency (Hz)	50/60
Length of Electrical Supply Cord (cm)	0
Plug type	No
Gas connection	N/A
Width of the product	580
Height of the product	46
Depth of the product	510
Minimum niche height	42
Minimum niche width	560
Niche depth	490
Net weight (kg)	8.5
Automatic programmes	No

TECHNICAL FEATURES

Power on indicator	Yes
Number of indicators	4
Type of regulation	Temperature regulated
Type of lid	Without
Residual heat indicator	Separate
Main on/off switch	Yes
Safety device	-
Timer	Yes

PERFORMANCES

Energy input	Electric
--------------	----------