

# DIO 3C24 AC E

12NC: 869991586820

GTIN (EAN) code: 8050147586822

**INDESIT**  
Life proof.

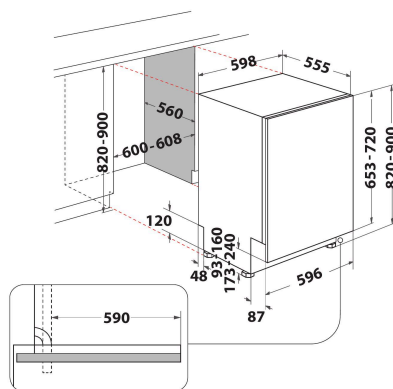

## MAIN FEATURES

Construction type	Vstavaná
Installation type	Plne vstavaná
Type of control	Electronic
Type of control settings	Digit
Removable work top	Nie
Main colour of product	White
Electrical connection rating (W)	1900
Current (A)	10
Voltage (V)	220-240
Frequency (Hz)	50
Length of Electrical Supply Cord (cm)	130
Plug type	Schuko
Length inlet hose (cm)	155
Length outlet hose (cm)	150
Adjustable feet	Yes - all
Height of the product	820
Width of the product	598
Depth of the product	555
Minimum niche height	0
Maximum niche height	0
Minimum niche width	0
Maximum niche width	0
Niche depth	560
Net weight (kg)	35.5
Gross weight (kg)	37.5

## TECHNICAL FEATURES

Automatic programmes	Áno
Maximum temperature for water intake (°C)	60
Start delay options	Continuous
Start delay time max. (h)	12
Progress indicator	-
change to:	Nie
Salt light indicator	Áno
Rinse aid light indicator	Áno
Safety device	Nie
Adjustable upper basket	Áno
Largest loadable dish upper basket (cm)	0
Largest loadable dish lower basket (cm)	0
Maximum number of place settings (EU 2017/1369)	14
Column installation	Nie

## ENERGETICKÝ ŠTÍTK

Energy Efficiency Class (Regulation (EU) 2017/1369)	E
Energy Consumption for 100 cycles Eco Programme (EU 2017/1369)	95
Power consumption in standby mode (Psm) (EU 2017/1369)	0,50
Power consumption in off-mode (Po) (EU 2017/1369)	0,00
The water consumption of the eco programme in liters per cycle (EU 2017/1369)	9,5
Airborne acoustical noise emissions (EU 2017/1369)	44
Airborne acoustical noise emission class (EU 2017/1369)	B
Programme duration in HMM (EU 2017/1369)	3:10