

Product data sheet

KitchenAid

Control panel	4
Warming drawer	4
Operation	4
Temperature selection	5
Warming times	5
Load capacity	6
Keeping foods hot	7
Drawer removal	8

Control panel

1. Temperature knob
2. Luminous ON-OFF switch
3. ON-OFF Indicator

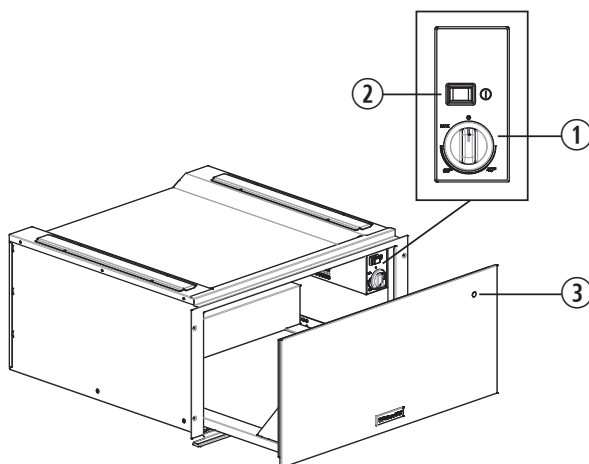

Warming drawer

The control elements are the temperature knob and the luminous **ON-OFF switch**.

With the switch pressed (position **1**), the drawer is on, whereas with the switch released (position **0**), the drawer is off.

These elements are only visible when the drawer is open.

When the drawer is closed, a control light located on the front of the appliance indicates if the drawer is on.

Operation

- Place the dishes in the drawer
- Set a temperature
- Turn the appliance on; the switch lights up
- Close the drawer, guiding it carefully
- Turn the appliance off before removing the warmed dishes.

Temperature selection

The temperature control knob allows adjustments up to approx. 75°C (max).

Turn the temperature knob clockwise until the stop which indicates maximum, and then anticlockwise.

Do not force it beyond the stop, otherwise the thermostat will become damaged.

Temperature adjustment	Instructions for use	
40°C	cups, glasses	Cups and glasses warmed at this temperature help delay the cooling time of the beverage subsequently added. The container can still be touched without any problems
60°C	plates	Plates warmed at this temperature help delay the cooling time of food subsequently placed on them. Depending on the individual sensitivity, the containers can be touched without any risk, otherwise use gloves or potholders.
MAX (approx. 75°C)	crockery	The thermostat is set to the maximum temperature. The containers can be touched ONLY with suitable gloves or potholders.

Warming times

The time required to warm dishes, glasses, etc. depends on various factors:

- Material and thickness of the dishes
- Load
- Arrangement of load
- Temperature setting

Therefore absolute indications cannot be given.

It is advisable to establish the optimum settings required, according to practical experience.

Load capacity

The load capacity depends on the height of the appliance and the size of the dishes.
Remember that the drawer can take a maximum weight of 25 kg.

12	plates	ø 24cm
12	broth cups	ø 10cm
1	tray	ø 19cm
1	tray	ø 17cm
2	meat plates	ø 32cm

Note: the quantities are purely indicative.

ATTENTION:

The glass surface of the heating zone will be hot.

The bottom side of the oven dish will be hotter than the top.

Keeping foods hot

Do not place hot dishes or pans on the glass surface of the heating drawer immediately after removing them from the hot cooktop. This could damage the glass surface. Do not over-fill oven dishes, to prevent food from spilling out.

Cover the food with a heat-resistant lid or aluminum foil. Do not keep foods hot for more than one hour. The appliance is designed to keep meat, poultry, fish, sauces, vegetables, side dishes and soups warm.

Procedure to follow

1. Place the oven dishes in the drawer.
2. Set the selector to max and preheat the appliance for 15 minutes.
3. Add the food to the preheated oven dishes.
4. Close the drawer.

The indicator light comes on: the appliance heats up.

Switching off the warming drawer.

Remove the food from the drawer using oven gloves or pot holders.

Uses

The table shows the possible uses of the heating drawer. Turn the function selector to the required setting. Preheat the plates as shown in the table.

Temperature adjustment	Type of food	Note
30/40°C	Delicate frozen foods, such as cream-based desserts, butter, sausages, cheese	Defrosting
30/40°C	Leavening dough	Cover
40/50°C	Frozen foods, such as meat, desserts, bread	Defrosting
40/50°C	Keeping eggs hot, such as boiled or scrambled eggs	Preheating plates, cover foods
40/50°C	Keeping bread hot	Preheating plates, cover foods
50/70°C	Keeping foods hot	Preheating plates, cover foods
50/70°C	Keeping beverages hot	Preheat plates, cover beverages
50/70°C	Heating flat dough foods, such as piadinas	Preheating plates, cover foods
50/70°C	Heating dry desserts, such as sweet pies	Preheating plates, cover foods
50/70°C	Melting chocolate and confectioner's chocolate	Preheat plates, chop foods
50/70°C	Dissolving gelatin	Do not cover, approx. 25 minutes
Max	Preheating plates	

Arranging the food

Note: in most cases, it is recommended to cover the foods in order to reduce humidity, which is hazardous for the appliance.

The heating time depends on a number of factors:

- the quantity of foods placed inside;
- the type of foods placed inside;

It is not considered possible to provide precise information on arranging the foods.

This may vary according to personal preferences.

Where possible, distribute the food across the whole surface.

Drawer removal

ATTENTION:

- Use protective gloves
- Disconnect the appliance from the power supply.

The drawer can be removed to clean it internally.
Open the drawer completely (**figure 1**).

Undo the two side screws (one on each side) (**figure 2**).

Pull out the sliding part of the drawer carefully, holding it at the front and side with both hands (**figure 3**).

The appliance can now be cleaned internally, using detergent and water.

Do not place the drawer in water once removed.

Refitting the drawer

To refit the drawer, carry out the removal procedure in reverse order.

To do this, place the drawer on the runners.

Make sure to:

Insert the drawer with the runners completely out.
Hold the runners with one hand and push the drawer until alignment of the two side holes (**figures 4-5**).



Figure 1

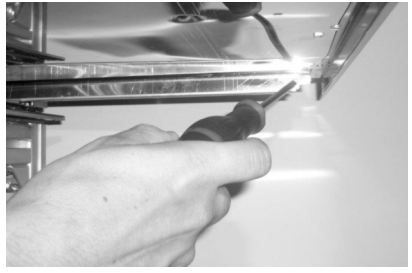

Figure 2



Figure 3

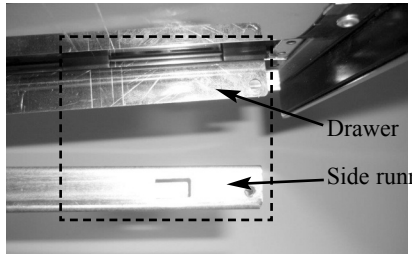

Figure 4

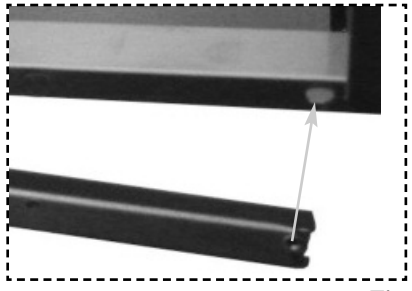

Figure 5



FOR THE WAY IT'S MADE.

Printed in Italy

Q 10/16

400010903084

