

Whirlpool



User Manual



www.whirlpool.eu/register



USER MANUAL



THANK YOU FOR BUYING A WHIRLPOOL PRODUCT.

In order to receive a more complete assistance, please register your product on www.whirlpool.eu/register.

INDEX

HEALTH & SAFETY GUIDE.....	3
SAFETY INSTRUCTIONS.....	3
USE & CARE GUIDE.....	5
Product description.....	5
Control panel.....	5
Accessories.....	6
How to use the appliance.....	6
First time use.....	6
Settings.....	7
Daily use.....	8
Favorites.....	10
Special functions.....	11
Cooking table.....	13
Maintenance and cleaning.....	14
Wi-Fi FAQ.....	14
Troubleshooting.....	15
Sounds produced during operation.....	16
Verified cooking.....	16
After-sales service.....	16
INSTALLATION GUIDE.....	17

SAFETY INSTRUCTIONS

IMPORTANT TO BE READ AND OBSERVED

Before using the appliance, read these safety instructions. Keep them nearby for future reference. These instructions and the appliance itself provide important safety warnings, to be observed at all times. The manufacturer declines any liability for failure to observe these safety instructions, for inappropriate use of the appliance or incorrect setting of controls.

⚠ **WARNING:** The appliance and its accessible parts become hot during use. Care should be taken to avoid touching heating elements.

Children less than 8 years of age shall be kept away unless continuously supervised.

⚠ **WARNING:** If the hob surface is cracked, do not use the appliance - risk of electric shock.

⚠ **WARNING:** Danger of fire: Do not store items on the cooking surfaces.

⚠ **CAUTION:** The cooking process has to be supervised. A short cooking process has to be supervised continuously.

⚠ **WARNING:** Unattended cooking on a hob with fat or oil can be dangerous - risk of fire. NEVER try to extinguish a fire with water: instead, switch off the appliance and then cover flame e.g. with a lid or a fire blanket.

⚠ Do not use the hob as a work surface or support. Keep clothes or other flammable materials away from the appliance, until all the components have cooled down completely - risk of fire.

⚠ Metallic objects such as knives, forks, spoons and lids should not be placed on the hob surface since they can get hot.

⚠ Very young children (0-3 years) should be kept away from the appliance. Young children (3-8 years) should be kept away from the appliance unless continuously supervised. Children from 8 years old and above and persons with reduced physical, sensory or mental capabilities or lack of experience and knowledge can use this appliance only if they are supervised or have been given instructions on safe use and understand the hazards involved. Children must not play with the appliance. Cleaning and user maintenance must not be carried out by children without supervision.

⚠ After use, switch off the hob element by its control and do not rely on the pan detector.

PERMITTED USE

⚠ **CAUTION:** the appliance is not intended to be operated by means of an external switching device, such as a timer, or separate remote controlled system.

⚠ This appliance is intended to be used in household and similar applications such as: staff kitchen areas in shops, offices and other working environments; farm houses; by clients in hotels, motels, bed & breakfast and other residential environments.

⚠ No other use is permitted (e.g. heating rooms).

⚠ This appliance is not for professional use. Do not use the appliance outdoors.

INSTALLATION

⚠ The appliance must be handled and installed by two or more persons - risk of injury. Use protective gloves to unpack and install - risk of cuts.

⚠ Installation, including water supply (if any), electrical connections and repairs must be carried out by a qualified technician. Do not repair or replace any part of the appliance unless specifically stated in the user manual. Keep children away from the installation site. After unpacking the appliance, make sure that it has not been damaged during transport. In the event of problems, contact the dealer or your nearest After-sales Service. Once installed, packaging waste (plastic, styrofoam parts etc.) must be stored out of reach of children - risk of suffocation. The appliance must be disconnected from the power supply before any installation operation - risk of electric shock. During installation, make sure the appliance does not damage the power cable - risk of fire or electric shock. Only activate the appliance when the installation has been completed.

⚠ Carry out all cabinet cutting operations before fitting the appliance and remove all wood chips and sawdust.

⚠ If the appliance is not installed above an oven, a separator panel (not included) must be installed in the compartment under the appliance.

ELECTRICAL WARNINGS

⚠ It must be possible to disconnect the appliance from the power supply by unplugging it if plug is accessible, or by a multi-pole switch installed upstream of the socket in accordance with the wiring rules and the appliance must be earthed in conformity with national electrical safety standards.

⚠ Do not use extension leads, multiple sockets or adapters. The electrical components must not be accessible to the user after installation. Do not use the appliance when you are wet or barefoot. Do not operate this appliance if it has a damaged power cable or plug, if it is not working properly, or if it has been damaged or dropped.

⚠ If the supply cord is damaged, it must be replaced with an identical one by the manufacturer, its service

agent or similarly qualified persons in order to avoid a hazard - risk of electric shock.

CLEANING AND MAINTENANCE

⚠ WARNING: Ensure that the appliance is switched off and disconnected from the power supply before performing any maintenance operation; never use steam cleaning equipment - risk of electric shock.

⚠ Do not use abrasive or corrosive products, chlorine-based cleaners or pan scourers.

DISPOSAL OF PACKAGING MATERIALS

The packaging material is 100% recyclable and is marked with the recycle symbol .

The various parts of the packaging must therefore be disposed of responsibly and in full compliance with local authority regulations governing waste disposal.

DISPOSAL OF HOUSEHOLD APPLIANCES

This appliance is manufactured with recyclable or reusable materials. Dispose of it in accordance with local waste disposal regulations. For further information on the treatment, recovery and recycling of household electrical appliances, contact your local authority, the collection service for household waste or the store where you purchased the appliance. This appliance is marked in compliance with European Directive 2012/19/EU, Waste Electrical and Electronic Equipment (WEEE). By ensuring this product is disposed of correctly, you will help prevent negative consequences for the environment and human health.

The symbol  on the product or on the accompanying documentation indicates that it should not be treated as domestic waste but must be taken to an appropriate collection center for the recycling of electrical and electronic equipment.

ENERGY SAVING TIPS

Make the most of your hot plate's residual heat by switching it off a few minutes before you finish cooking.

The base of your pot or pan should cover the hot plate completely; a container that is smaller than the hot plate will cause energy to be wasted. Cover your pots and pans with tight-fitting lids while cooking and use as little water as possible. Cooking with the lid off will greatly increase energy consumption.

Use only flat-bottomed pots and pans.

DECLARATION OF CONFORMITY

This appliance meets the Ecodesign requirements set out in European Regulation n. 66/2014, in conformity to the European standard EN 60350-2.

The Manufacturer, Whirlpool EMEA S.p.A., declares that this I200 Maestro model of household appliance with radio equipment is compliant with directive 2014/53/UE.

The complete text of the declaration of conformity is present at the following website: <https://docs.whirlpool.eu>.

The radio equipment operates in the 2.4 GHz ISM frequency band, the maximum radio-frequency power transmitted does not exceed 20 dBm (e.i.r.p.).

This product includes certain open source software developed by third parties. The open source license usage statement is available at the following website: <https://docs.whirlpool.eu>.



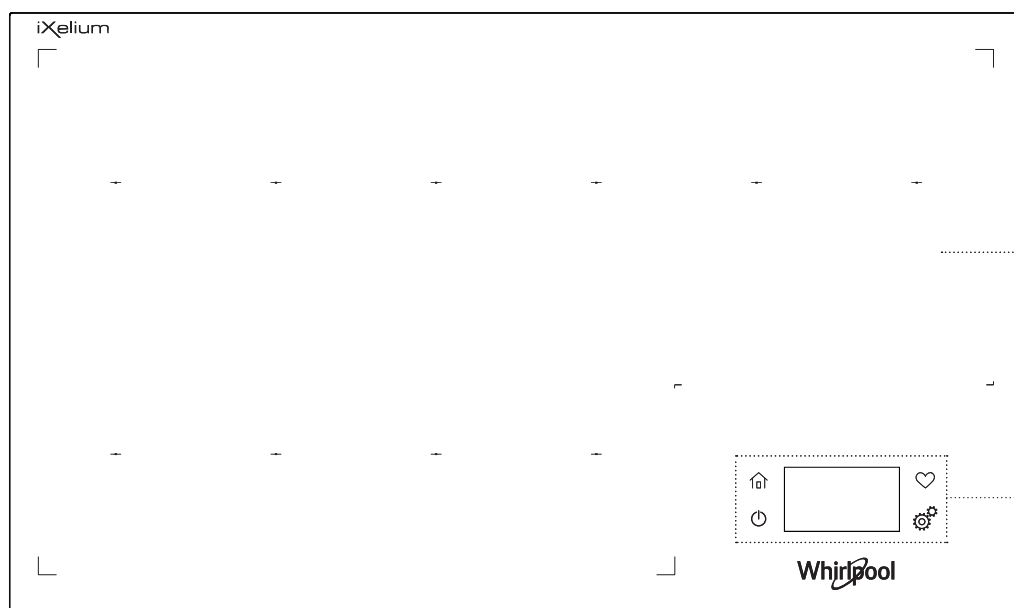

PRODUCT DESCRIPTION

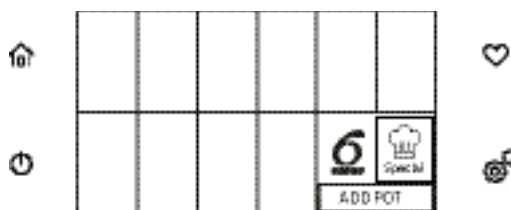

1. Hob
2. Control panel

CONTROL PANEL



	Switching the hob on/off	Dedicated button for switching the whole hob on and off. The button is always active on any screen and whatever the status of the hob.
	Main screen	Dedicated button for accessing the initial screen, can be selected at any time during navigation.
	Favorites	Dedicated button for activating the screen containing the list of the hob's saved or suggested functions.
	Hob settings	Dedicated button for accessing all the hob's settings and configurations.

ACCESSORIES

POTS AND PANS

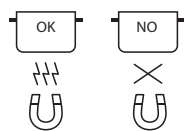

Only use pots and pans made from ferromagnetic material which are suitable for use with induction hobs. To determine whether a pot is suitable, check for the  symbol (usually stamped on the bottom). A magnet may be used to check whether pots are

magnetic.

The quality and the structure of the pot base can alter cooking performance. Some indications for the diameter of the base do not correspond to the actual diameter of the ferromagnetic surface.

EMPTY POTS OR POTS WITH A THIN BASE

Do not use empty pots or pans when the hob is on.

The hob is equipped with an internal safety system that constantly monitors the temperature, activating the "automatic off" function where high temperatures are detected.

When used with empty pots or pots with thin bases, the temperature may rise very quickly, and the "automatic off" function may be triggered with a slight delay, damaging the pot or pan. If this occurs, do not touch anything, and wait for all components to cool down.

If any error messages appear, call the service centre.

MINIMUM DIAMETER OF POT/PAN BASE FOR THE DIFFERENT COOKING AREAS

To ensure that the hob functions properly, the pot must cover one or more of the reference points indicated on the surface of the hob, and must be of a suitable minimum diameter.

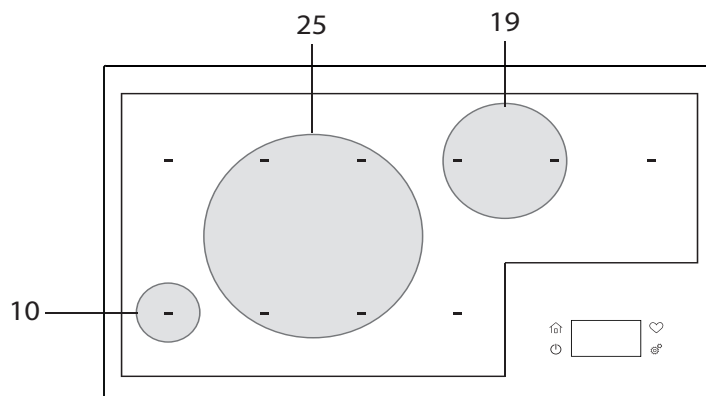

(Diameter of the base of the pot in centimetres)

HOW TO USE THE APPLIANCE

FIRST TIME USE

Sequential setting of required parameters when the hob is first switched on.

To adjust the settings at a later date, enter the Settings menu "⚙️".

1	Language	Scroll through the list to select the required language and then press to confirm.	STORE DEMO NEXT
2	Wi-Fi	Sets up the connection between the appliance and the household internet network (see detail sheet). If the Wi-Fi connection is set up now, the date and time will be automatically acquired by the system. The Wi-Fi connection may also be set up later, and the date and time may be set manually now.	SETUP NOW SKIP
3	Time	Sets the time in mm:hh. The format may be modified later in the system settings.	
4	Date	Sets the date in the format gg:mm:aaaa. The format may be modified later in the system settings.	
5	Power	Sets the maximum power of the hob, selectable from the following values: 2.5 kW – 4.0kW – 6.0kW – 7.2kW – 11.0kW.	

STORE DEMO MODE :

Mode used in retail outlets to present the main functions of the menu. To return to the original menu sequence, press the settings button "⚙️" and deselect demo mode from the menu section "Information". After deselecting the mode, press the Main Screen button "⏪".



USING THE TOUCHSCREEN

- To browse the menus, simply touch the screen by tapping the display with your finger;
- Depending on how hard you touch the screen with your finger, the speed at which the screen moves can be adjusted;
- To select or confirm a choice, touch the screen according to the chosen value or menu item;

- The previous or following displays can be accessed by pressing the dedicated "Next" and "Go Back" buttons;
- Buttons that appear to be greyed out relate to functions which cannot currently be selected.



SETTINGS

The hob settings can be changed at any time. To change the settings, press the "⚙️" button.

 Timer	Accesses the timer function when the hob is switched off.
 Mute	Mutes all the indicator sounds of the hob.
 Control Lock	Disables button input. Follow the instructions given on the display to deactivate the mode.
Other options - Power management	Adjusts the power of the hob in accordance with individual preferences or with the maximum power rating of your mains electricity meter: 2.5kW – 4.0kW – 6.0kW – 7.2kW – 11.0kW.
Preferences:	
Time & Date	For setting meal times, date, time and formats.
Alert sound volume	Sets the volume of the alert sounds for the timer and buttons.
Display Settings - Brightness	Sets the brightness of the display, with three selectable levels: high, medium, low.
Geographic zone - Language	For selecting the language;
Wi-Fi	For connecting the appliance to a Wi-Fi network (see relative paragraph).
Information	For displaying contact information for the After-sales service, accessing Demo Mode or resetting the hob to the factory settings. Select Demo Mode and use the Free Play function to learn how to browse the menus of the hob.

WI-FI SETTINGS

To set up the Wi-Fi connection, press the "⚙️" button and "Wi-Fi" appears on the screen.

 Wi-Fi	
Connect to Network  >	Download the Whirlpool app from the app store for your smartphone. Launch the app to connect your appliance.
SAID code >	The SAID code is used to associate a smart device with the appliance. Contact the after-sales service if the SAID label has been lost.
MAC address >	The MAC address is shown on the display for the Wi-Fi module.
Wi-Fi ON	Switch the Wi-Fi connection on and off with the on/off button.

DAILY USE

SWITCHING THE HOB ON/OFF

To switch the hob on, press the on button for approx. 1 second until the display lights up.

If no function is selected, the hob will automatically switch off after 10 seconds.

To turn the hob off, press and hold the same button again until the display turns off and all the cooking zones are deactivated.

SELECTING THE COOKING ZONE

The desired cooking zone can be selected on the display, by pressing the corresponding pane.

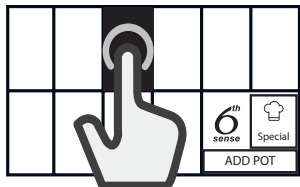

If the hob does not detect a pot, the corresponding warning message appears on the display.

ACTIVATING/DEACTIVATING COOKING ZONES AND ADJUSTING POWER

To activate the cooking zones:

1. Switch on the hob. If a recipient is already in place, the hob automatically detects it. Select the suggested zone to choose the power.
2. Place the pot in the chosen cooking zone, ensuring that it is covering one or more of the reference points on the surface of the hob.

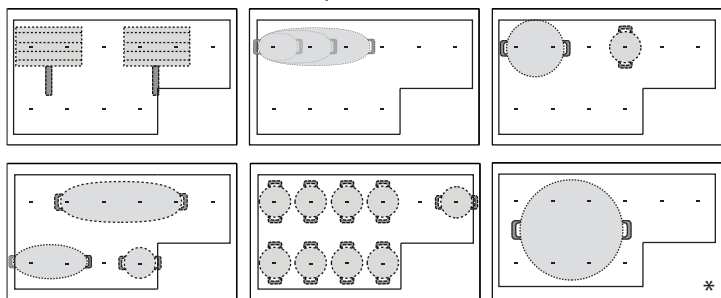

* Using this position will allow you to benefit from maximum power output.

Please note: Do not cover the display with accessories. If a utensil is covering the display, the hob may not function properly.

3. Once the zone has been defined, the screen appears allowing the power level to be selected.
4. Set the desired power level by pressing or moving your finger horizontally and confirm with the "START" button. The power level set will appear in the pane of the cooking zone selected.

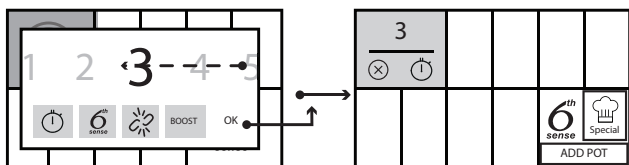

Each cooking zone offers a range of different heat settings, from "1" (minimum power) to "18" (maximum power).

Using the power level screen, you can also select the quick heat function, which is displayed on the screen with the "Boost" button.

Please note: If the pot is not suitable for induction cooking, or is not positioned correctly or is not of an appropriate size, the following appears: "No pot detected in this zone." If no pot is detected within 30 seconds of making the selection, the cooking zone switches off.

To deactivate the cooking zones:

Select the cooking zone on the display and press the "X" button.

If the cooking zone is still hot, the residual heat indicator "HOT" appears in the corresponding pane.

RESIDUAL HEAT INDICATOR

When the "HOT" symbol appears on a cooking zone, it means that the corresponding zone is still hot. When the cooking zone has cooled down, the "HOT" symbol disappears.

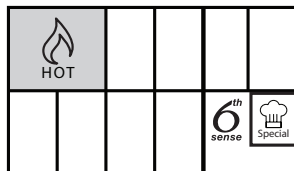

If some zones are still hot when the hob is turned off, a visible warning remains displayed.

SELECTING THE FLEXIBLE AREA

The flexible area consists of multiple cooking zones that are joined together, but are controlled as one zone.

To create a flexible area:

If the hob already features the accessory, the display shows the available zones, simply press the "∞" button to confirm.

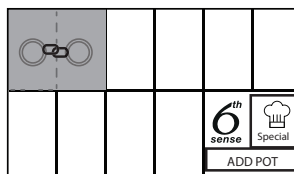

If you wish to create the area manually, slide your finger along the surface and gradually join the desired zones together, guided by a series of directional arrows. Certain combinations are not possible due to their shape or the fact that other zones are in use.

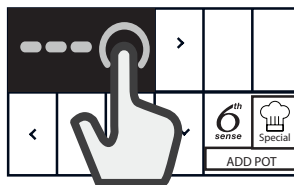

To divide a flexible area:

When you press on the area, a dedicated screen appears, you can then select the "☼" symbol, which allows you to divide the joined areas. The areas can once again be operated individually, each with the same power level.

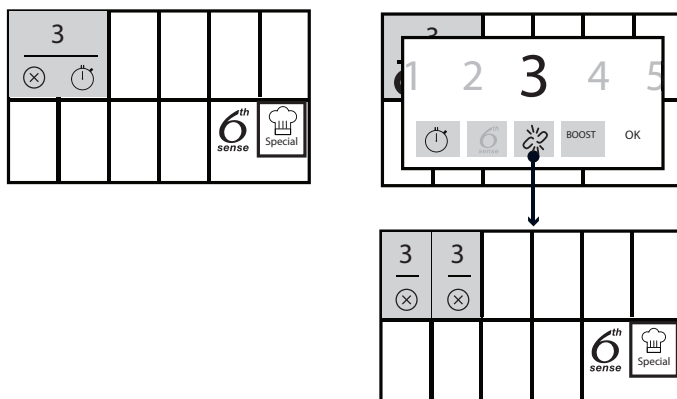

ADD POT

When using a cooking area composed of several zones, the pot can be placed anywhere on the active cooking zone. The hob will automatically recognise the actual positioning of the pot.

If you wish to add an additional pot to the active cooking zone, use the "add pot" command to allow the hob to detect the new pot.

**TIMER**

There is the option of setting a useful timer suited to a whole range of requirements, even when the hob is not on.

To activate the timer:

1. Switch on the hob.
2. Press the settings button "⚙️" and select the timer "⌚".
3. Set the desired time in the format hh:mm:ss.
There are three pre-set values, making it easier to adjust to the required time.
4. Press the "Start" button.
After selection, if the screen is not then touched for one minute it turns black, leaving the countdown displayed.
5. When the set time has elapsed, an acoustic signal sounds.

To adjust the timer:

1. Switch on the hob.
2. Press the settings button "⚙️" and select the timer "⌚".
3. Press the centre of the screen and adjust the values.

To deactivate the timer press "CANCEL".

Once the time has elapsed, a new time can be set or the timer can be switched off.

**SETTING THE COOKING TIMER**

The cooking zones can be programmed to switch off automatically.

To set the cooking time:

1. Select the cooking zone and set the required power level.
2. Press the stopwatch button "⌚" that appears on the active cooking zone.
3. Set the desired time in the format hh:mm:ss.
4. Press the "Start" button.

A bar will appear in the corresponding zone, and will fill up as the time gradually progresses.

To adjust the set cooking time:

1. Press the power level.
2. Press the "⌚" button.
3. Adjust the set cooking time.

To deactivate the set cooking time press "CANCEL".

A cooking time can be set for each zone or flexible area by following the same steps.

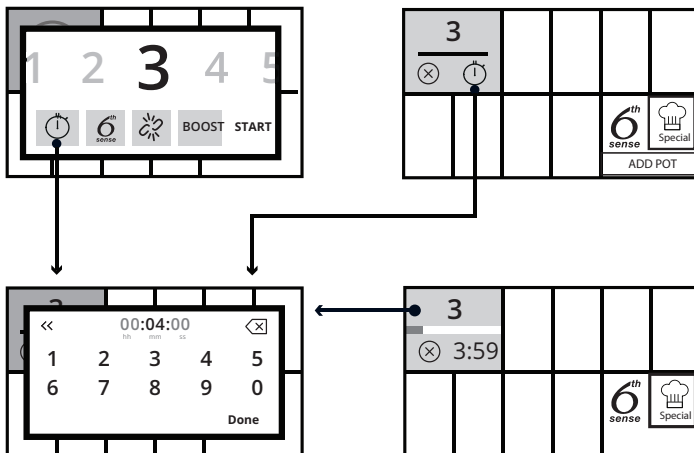
**CONTROL LOCK**

To prevent activation of the hob during cleaning or to prevent controls being changed during cooking, the hob can be locked using the "🔒" control in "Settings" "⚙️". The control panel will be locked, with the exception of the off button. To reactivate the controls, slide your finger towards the top of the display.

FAVORITES

At any time using the “♥” button, you can save a recipe or pre-set cooking program to favourites, choosing the required time of day. The favourites section is a useful space where the most frequently used cooking programs can be saved in one or more categories, according to the typical dishes eaten at certain times of day:

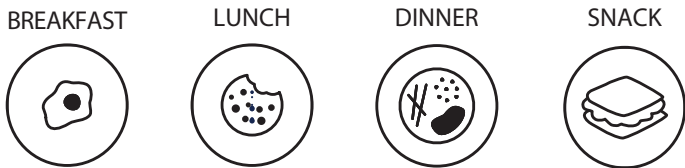

MEAL TIMES

In “Settings” (Favorites menu - Date and Time), under “Meal times”, the hourly interval for each category can be adjusted (e.g.: breakfast 7-9, lunch 12-14...).

CREATING FAVOURITES

On the “Favorites” screen (accessed using the direct “♥” button on the glass) a required sequence (power + time) or an assisted cooking method can be saved in one of the four suggested categories. This favourite can be adjusted at any time.

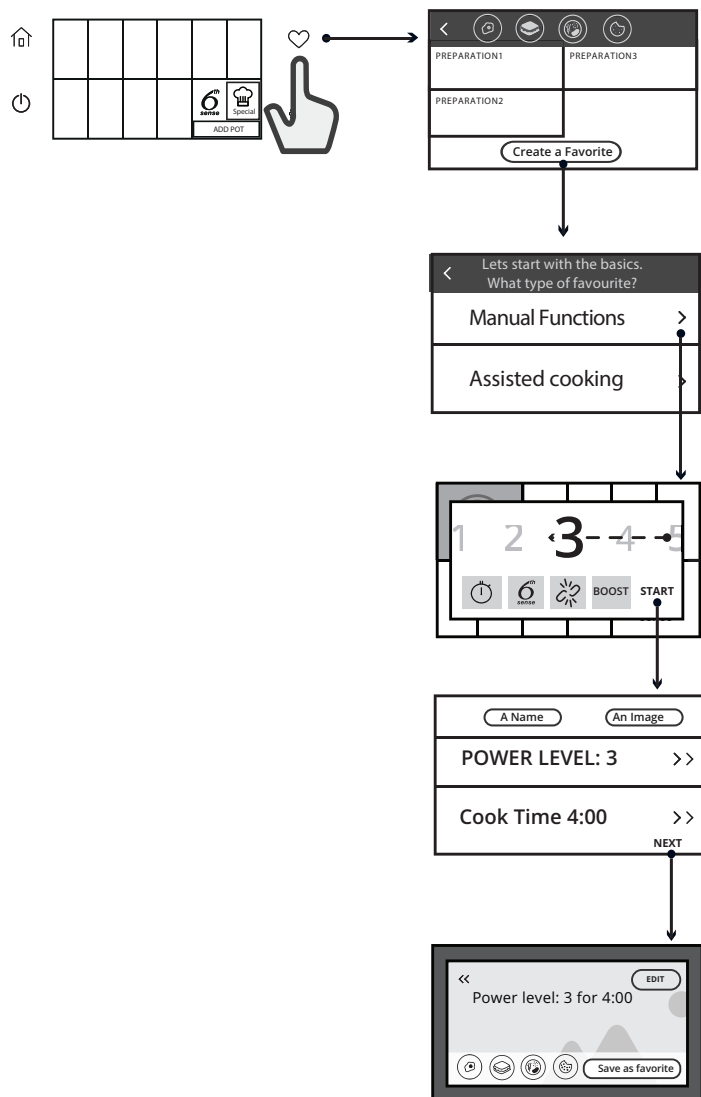

Select one or more categories by highlighting the corresponding symbols.

ADDING A FAVOURITE

At the end of every assisted cooking function, the symbol “♥” appears, meaning that the preparation method you have just used can be saved and added to the category of your choice. Select one or more categories by highlighting the corresponding symbols.

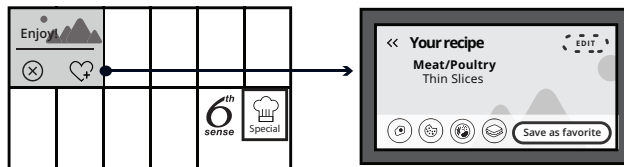

During normal use, if a cooking time is set, the “♥” symbol appears, meaning that the power level you were using and the time you previously set can both be saved.

This function is useful should you wish to refer back to a preparation method that you use frequently.

SPECIAL FUNCTIONS

6th sense 6th SENSE

The 6th Sense button activates assisted cooking, which allows you to select numerous cooking methods for a whole range of food. With this function, the hob activates a system to help with and manage all the cooking phases, from heating up the pot (with or without seasoning) to maintaining the best temperature during cooking. Based on the preparation method selected, the hob provides instructions for each step, suggesting ingredients and the ideal times to add them.

After having selected "6th", you enter the menu containing the different categories of food (see table) and the "personalised" mode, from which you can directly select several assisted cooking methods.

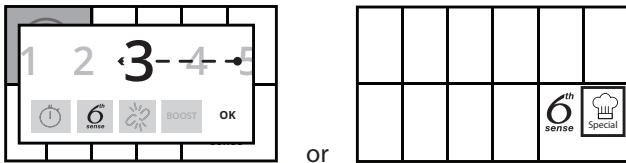

Once you have chosen the type of food, you enter a second screen from which you can choose from one of the proposed cooking methods for the category in question and, when necessary, it suggests conditions to ensure the system is as effective as possible (e.g. the thickness of meat).

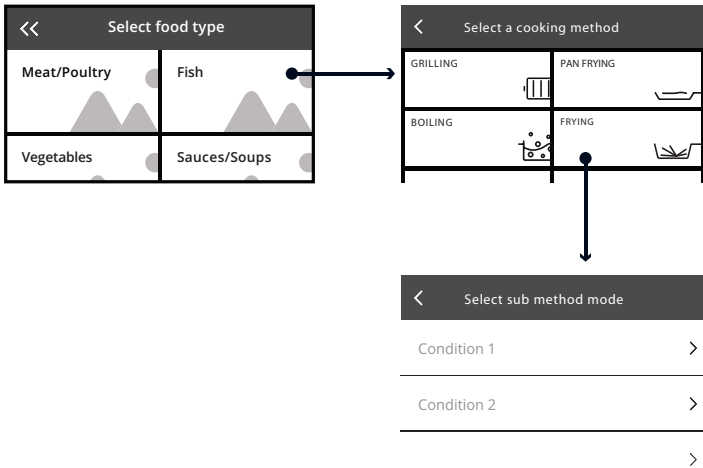

When all the required functions have been selected, the available zones are displayed on the screen, you then have to choose which you would like to cook on. As shown in the figure, it is important that, during assisted cooking, the pan is always positioned on two zones, in order to cover both circles. To this end, the zones already considered to be joined are displayed on the screen. (The only exception is the moka function, for which only one zone will be suggested for use).

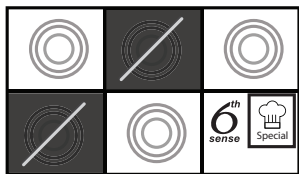

The screen that follows displays a summary and any advice, if necessary (e.g. the use of a dedicated accessory).

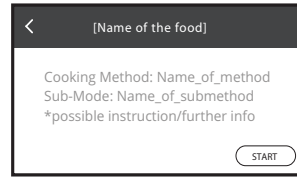

The cooking phase is then activated and, where present, the preheating bar, relating to the accessory that is empty or filled with water or oil, is displayed.



The progress can be checked at any time by pressing the active zone (be careful not to press "X"). The screen displays the state of progress and the number of total phases required for each preparation method.



Only if the "DONE" button is pressed, does the system move to the next phase required for each preparation method. The cooking time can also be selected on the same screen (not during preheating), or the "X" button can be pressed to end the function. The third symbol (Adjust) offers the possibility of controlling and fine tuning the rate of cooking, ideal should you wish to tailor it to suit your own personal taste. On this screen it is also possible to move across the 5 levels, (+1, +2 or -1, -2), so that the system can gently adjust the power and the temperature.



When the various steps have been completed, if a cooking time or the "X" button is pressed, the function is ended.

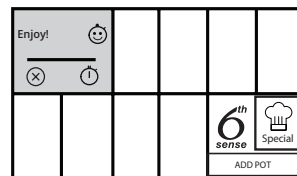

This table summarises all navigation relating to assisted cooking, with the product categories, cooking methods and, where applicable, the preparation methods with full recipes.

This table does not include all the necessary details relating to quantities, or other settings, which may be requested when selecting the preparation methods.

Possible preparation methods

FOOD CATEGORY	COOKING METHOD
Meat/Poultry	Grilling, pan-frying, boiling, frying
Fish	Grilling, pan-frying, boiling, frying
Vegetables	Grilling, pan-frying, boiling, frying
Sauces, gravies, soups	Sauces (sautéing, simmering, bechamel) Soups (sautéing, simmering, creamy soups)
Dessert	Custard, panna cotta, melted chocolate, pancakes, rice pudding
Eggs	Fried eggs, omelette, boiling (boiled eggs, à la coque), frittata, scramble
Cheese	Grilling, pan frying, fondue
Pasta & Rice	Boiling, pan frying, rice
Beverages	Simmering (milk), water (boiling, simmering), moka
Custom	Boiling, grilling, pan frying, simmering, melting

MELTING

Ideal cooking method for increasing or maintaining temperatures suited to melting or thawing food such as chocolate, butter or, in general, more delicate preparation methods (e.g. custard, cream), preventing anything from sticking to the bottom of the pot.

SIMMERING

Ideal cooking method for increasing or maintaining temperatures suited to cooking and slowly evaporating liquids, for preparation methods that require long cooking times, sauces, soups, broths and, in general, recipes that require the liquids to cook on a low boil.

The rate of cooking can be adjusted at any time using the "+" and "-" buttons on the display.

The quality and type of pot can affect performance or cooking times.

BOILING*

Ideal cooking method for heating water and increasing to a controlled boil once full boil has been reached, preventing spillages and energy being wasted. When the water has started to boil, the hob displays a warning and sounds an alarm. Only add salt and seasonings after the alarm has sounded.

Whilst this function is active, the system informs you if the pot which has been positioned is accidentally empty (no water) or if it has boiled dry.

The rate of cooking can be adjusted at any time using the "+" and "-" buttons on the display.

The quality and type of pot can affect performance or cooking times.

PAN FRYING*

Ideal cooking method for increasing or maintaining temperatures suited to all preparation methods requiring the use of a pan with ingredients such as chopped onions (with up to a centimetre of oil), or with an empty accessory for quickly cooking items, meats and sautéing vegetables.

Once the pan, and later the ingredients, are in place, the hob starts the preheating phase. A warning is displayed and an alarm sounds to indicate the precise moment to add the food, based on the selected food category.

While awaiting confirmation from the user, the system continues to heat the accessory at a controlled level, preventing the pan or ingredients from overheating and energy being wasted.

Ideally, the function should be used starting with the pan and ingredients at room temperature, using the dedicated accessory.

Do not use the lid during the preheating phase.

The rate of cooking can be adjusted at any time using the "+" and "-" buttons on the display.



GRILLING*

Ideal cooking method for increasing or maintaining temperatures suited to all preparation methods that require the use of the wire rack, meat, fish, vegetables and cheese.

Once the wire rack is in place, the hob starts the preheating phase. A warning is displayed and an alarm sounds to indicate the precise moment to add the food, based on the selected food category.

While awaiting confirmation from the user, the system continues to heat the accessory at a controlled level, preventing the wire rack from overheating and energy being wasted.

Ideally, this function should be used with the wire rack at room temperature.

The rate of cooking can be adjusted at any time using the "+" and "-" buttons on the display.

If you are not using the wire rack designed for this purpose, take extra care when first using the grill function, as the quality of the base may affect the preheating time and accessories with very thin bases can reach very high temperatures in a short time.



FRYING*

Ideal cooking method for increasing or maintaining temperatures suited to all preparation methods that require food to be fully immersed in oil, regardless of whether the food products are fresh or frozen.

Once the pan is in place and the ingredients have been added, the hob starts the preheating phase.

A warning is displayed and an alarm sounds to indicate the precise moment to add the food, based on the selected food category.

While awaiting confirmation from the user, the system continues to heat the accessory at a controlled level, preventing the pan and ingredients from overheating and energy being wasted.

Ideally, the function should be used starting with the pan and ingredients at room temperature, using the dedicated accessory.

Do not use the lid during the preheating phase.

It is advisable to use oils that are suitable for frying when cooking with this function, such as seed oils of various types. When using different oils, always take extra care to supervise cooking during first use.

It is advisable to use the front cooking zones, in order to better control the rate of cooking.

The rate of cooking can be adjusted at any time using the "+" and "-" buttons on the display.



MOKA*

This function prepares coffee automatically. The heating cycle can be activated by selecting the function in the menu, and a beep will sound when the coffee is ready. The function is programmed to switch off automatically, preventing spills. When using for the first time, always check that the conditions described are met. Ideally, the function should be used starting with moka and water at room temperature, using the dedicated accessory.

***For these functions, the use of dedicated accessories is recommended:**

- for boiling: **WMF SKU: 07.7524.6380**
- for pan frying: **WMF SKU: 05.7528.4021**
- for grilling: **WMF SKU: 05.7650.4291**
- for frying: **WMF SKU: 07.7520.6380**
- for Moka, Bialetti: **MOKA INDUZIONE 3TZ ANTRACITE**

Please note: Try not to move the pot or pan during the first minute of heating, in order to allow the hob to function optimally.



SPECIAL FUNCTIONS

By pressing the “” button, you can activate the Flexifull and Chef Control functions.



FLEXIFULL

This function allows you to use the entire hob as a single cooking area.

To activate the Flexifull function:

1. Place the pot in position.
(It can also be positioned later on).
2. Press the “” button and select the Flexifull function.
3. Set the desired power level.
4. Press the “Start” button.
The set power level appears on the display.
5. If you wish to add more pots, use the “add pot” command.
6. To exit this function, press “EXIT”.

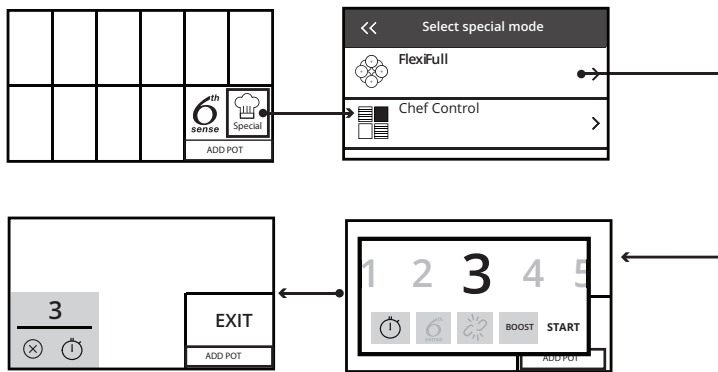

CHEF CONTROL

This function divides the hob into three cooking zones, activating these simultaneously at a pre-set power level. It allows you to move pots from one zone to another, allowing you to continue cooking at different temperatures without interfering with the power level selected.

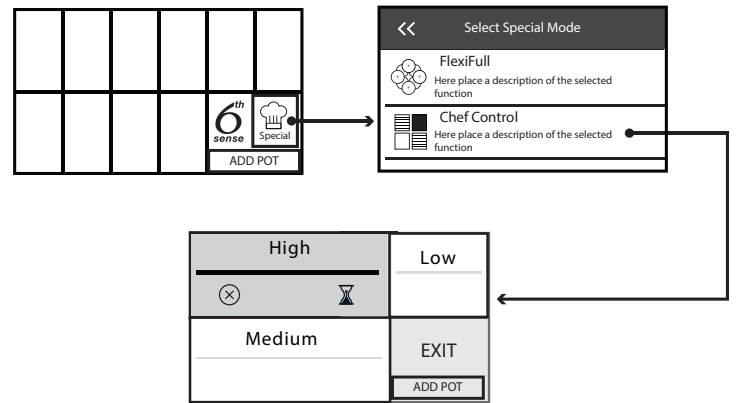

COOKING TABLE

POWER LEVEL		TYPE OF COOKING	RECOMMENDED USE Tips to supplement experience and cooking preferences
Max. power	Boost	Fast heating	Ideal for rapidly increasing the temperature of food to a fast boil (for water) or for rapidly heating cooking liquids.
	14 - 18	Frying, boiling	Ideal for browning, starting to cook, frying deep-frozen products, bringing liquids to the boil quickly.
		Browning, sautéing, boiling, grilling	Ideal for sautéing, maintaining a lively boil, cooking and grilling.
	10 - 14	Browning, cooking, stewing, sautéing, grilling	Ideal for sautéing, maintaining a gentle boil, cooking and grilling, and preheating accessories.
		Cooking, stewing, sautéing, grilling, cooking until creamy	Ideal for stewing, maintaining a gentle boil, cooking and grilling (for longer periods).
	5 - 9	Cooking, simmering, thickening, creaming	Ideal for slower-cook recipes (rice, sauces, roast, fish) with liquids (e.g. water, wine, broth, milk), and for creaming pasta.
			Ideal for slow-cook recipes (quantities under 1 litre: rice, sauces, roasts, fish) with liquids (e.g. water, wine, broth, milk).
1 - 4	Melting, thawing	Ideal for softening butter, gently melting chocolate, thawing small items.	
	Keeping food warm, creaming risotto	Ideal for keeping small portions of just-cooked food or serving dishes warm and for creaming risotto.	
Zero power		-	Hob in stand-by or off mode (hob may still be hot with residual heat from cooking, as indicated by symbol “”).

MAINTENANCE AND CLEANING



WARNING

- Do not use steam cleaning equipment.
- Before cleaning, make sure that the cooking zones are switched off and that the residual heat indicator "HOT" is not displayed.

Important:

- Do not use abrasive sponges or scouring pads as they may damage the glass.
- After each use, clean the hob (when it is cool) to remove any deposits and stains from food residue.
- Sugar or foods with a high sugar content can damage the hob and must be immediately removed.
- Salt, sugar and sand could scratch the glass surface.
- Use a soft cloth, absorbent kitchen paper or a special hob cleaner (follow the Manufacturer's instructions).
- Spills of liquid in the cooking zones can cause the pots to move or vibrate.
- After cleaning the hob, dry thoroughly.

If the iXelium™ logo appears on the glass, the hob has been treated with iXelium™ technology, an exclusive Whirlpool finish which ensures perfect cleaning results, as well as keeping the surface of the hob shiny for longer.

To clean iXelium™ hobs, follow these recommendations:

- Use a soft cloth (microfibre is best) dampened with water or with everyday glass cleaning detergent.
- For best results, leave a wet cloth on the glass hob surface for a few minutes.

Wi-Fi FAQ

Which WiFi protocols are supported?

The WiFi adapter installed supports WiFi b/g/n for European countries.

Which settings need to be configured in the router software?

The following router settings are required: 2.4 GHz enabled, WiFi b/g/n, DHCP and NAT activated.

Which Version of WPS is supported?

WPS 2.0 or higher. Check the router documentation.

Are there any differences between using a smartphone (or tablet) with Android or iOS?

You can use whichever operating system you prefer, it makes no difference.

Can I use mobile 3G tethering instead of a router?

Yes, but cloud services are designed for permanently connected devices.

How can I check whether my home Internet connection is working and wireless functionality is enabled?

You can search for your network on your smart device. Disable any other data connections before trying.

How can I check whether the appliance is connected to my home wireless network?

Access your router configuration (see router manual) and check whether the appliance's MAC address is listed on wireless connected devices page.

Where can I find the appliance's MAC address?

Press "Settings" then tap WiFi icon or look on your appliance: There is a label showing the SAID and MAC addresses. The Mac address MAC address consists of a combination of numbers and letters starting with "88:e7".

How can I check whether the appliance's wireless functionality is enabled?

Use your smart device and the 6th Sense Live app to check whether the appliance network is visible and connected to the cloud.

Is there anything that can prevent the signal reaching the appliance?

Check that the devices you have connected are not using up all the available bandwidth.

Make sure that your WiFi-enabled devices do not exceed the maximum number permitted by the router.

How far should the router be from the appliance?

Normally the WiFi signal is strong enough to cover a couple of rooms, but this very much depends on the material the walls are made of. You can check the signal strength by placing your smart device next to the appliance.

What can I do if my wireless connection does not reach the appliance?

You can use specific devices to extend your home WiFi coverage, such as access points, WiFi repeaters and power line bridges (not provided with appliance).

How can I find out the name of and password for my wireless network?

See the router documentation. There is usually a sticker on the router showing the information you need to reach the device setup page using a connected device.

What can I do if my router is using the neighbourhood WiFi channel?

Force the router to use your home WiFi channel.

What can I do if appears on the display or the appliance is unable to establish a stable connection to my home router?

The appliance might have successfully connected to the router, but it is not able to access the Internet. To connect the appliance to the Internet, you will need to check the router and/or carrier settings.

Router settings: NAT must be on, firewall and DHCP must be properly configured. Password encryption supported: WEP, WPA, WPA2. To try a different encryption type, please refer to the router manual.

Carrier settings: If your Internet service provider has fixed the number of MAC addresses able to connect to the Internet, you may not be able to connect your appliance to the cloud. The MAC address of a device is its unique identifier. Please ask your Internet service provider how to connect devices other than computers to the Internet.

How can I check whether data is being transmitted?

After setting up the network, switch the power off, wait 20 seconds and then switch on the appliance: Check that the app is showing the UI status of the appliance.

Some settings take several seconds to appear in the app.

How can I change my Whirlpool account but keep my appliances connected?

You can create a new account, but remember to remove your appliances from your old account before moving them to your new one.

I changed my router – what do I need to do?

You can either keep the same settings (network name and password) or delete the previous

TROUBLESHOOTING

- Check that the electricity supply has not been shut off.
- If you are unable to turn the hob off after using it, disconnect it from the domestic power supply.
- If alphanumeric codes appear on the display when the hob is switched on, consult the following table for instructions.

Error code	Description	Possible causes	Cure
C81, C82	The control panel switches off because of excessively high temperatures.	The internal temperature of electronic parts is too high.	Wait for the hob to cool down before using it again.
F02, F04	The connection voltage is wrong.	The sensor detects a discrepancy between the appliance voltage and that of the mains supply.	Disconnect the hob from the mains and check the electrical connection.
F01, F06, F12, F13, F25, F34, F35, F36, F37, F41, F47, F58, F61, F76	Disconnect the hob from the power supply. Wait a few seconds then reconnect the hob to the power supply. If the problem persists, call the service centre and specify the error code that appears on the display.		

SOUNDS PRODUCED DURING OPERATION

Induction hobs may whistle or creak during normal operation. These noises actually come from the cookware and are linked to the characteristics of the pan bottoms (for example, when the bottoms are made from different layers of material or are irregular).

These noises may vary according to the type of cookware used and to the amount of food it contains and are not the symptom of something wrong.

VERIFIED COOKING

A table below has been created specially to make it possible for inspection bodies to use our products.

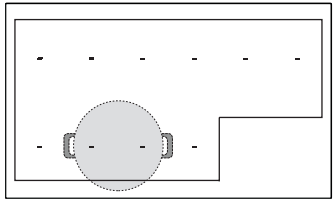
Verified cooking	Verified cooking positions
Heat distribution, "Pancakes" test acc. to EN 60350-2 §7.3	
Heat performance, "French fries" test acc. to EN 60350-2 §7.4	
Melting and keep warm, "chocolate"	
Simmering, "rice pudding"	

ECO-DESIGN: The test was carried out in accordance with regulations, by selecting all of the cooking zones on the hob to form a single area, or by using the FlexiFull function.

AFTER-SALES SERVICE

BEFORE CALLING THE AFTER-SALES SERVICE:

1. See if you can solve the problem by yourself with the help of the suggestions given in the **TROUBLESHOOTING**.
2. Switch the appliance off and back on again to see if the fault persists.

IF AFTER THE ABOVE CHECKS THE FAULT STILL OCCURS, GET IN TOUCH WITH THE NEAREST AFTER-SALES SERVICE.

To receive assistance, call the number shown on the warranty booklet or follow the instructions on the website **www.whirlpool.eu**.

When contacting our Client After sales service, always specify:

- a brief description of the fault;
- the type and exact model of the appliance;

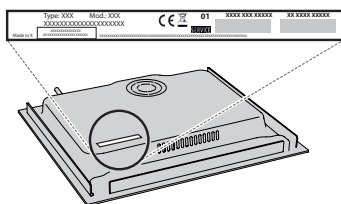

- the service number (number after the word Service on the rating plate). The service number is also indicated on the guarantee booklet;



- your full address;
- your telephone number.

If any repairs are required, please contact an authorized after-sales service (to guarantee that original spare parts will be used and repairs carried out correctly).

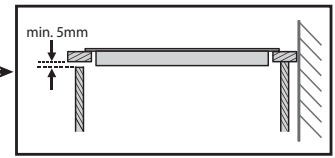
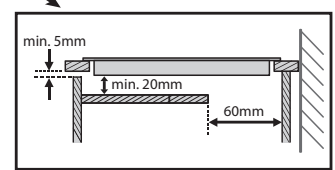
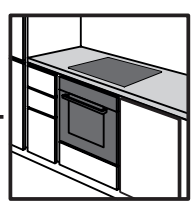
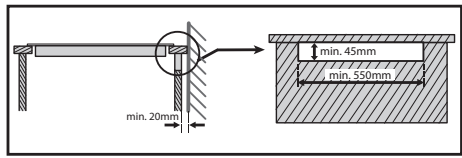
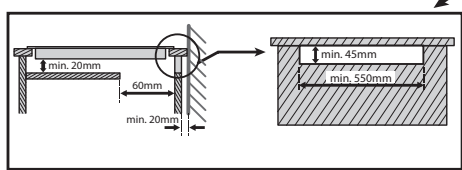
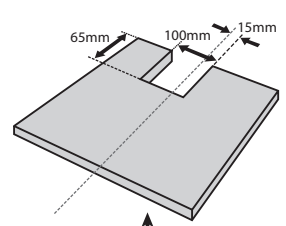
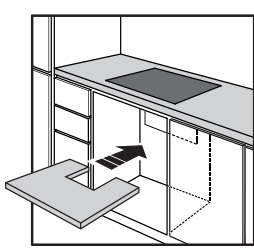
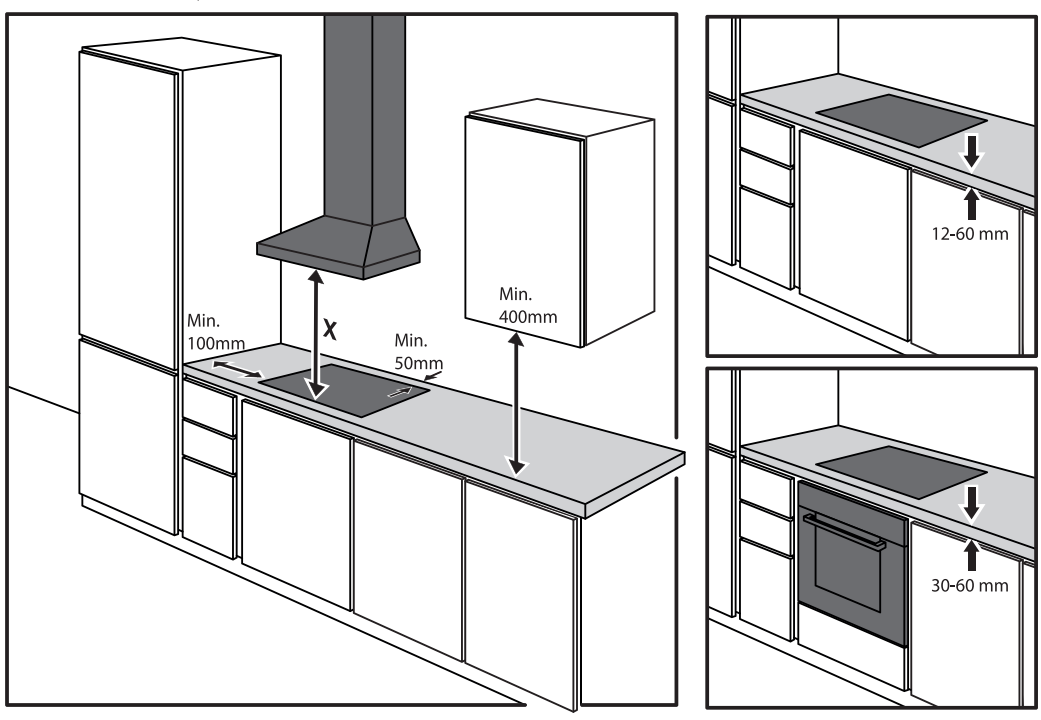
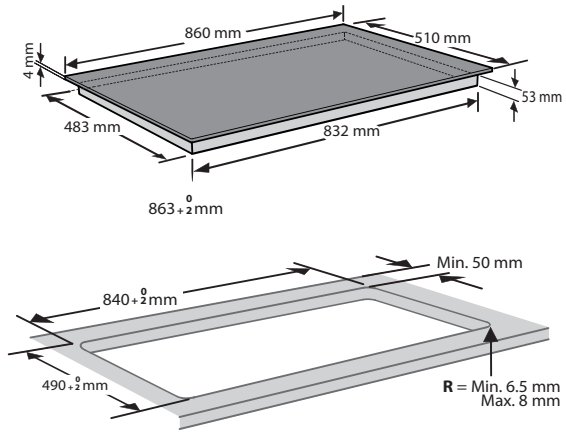

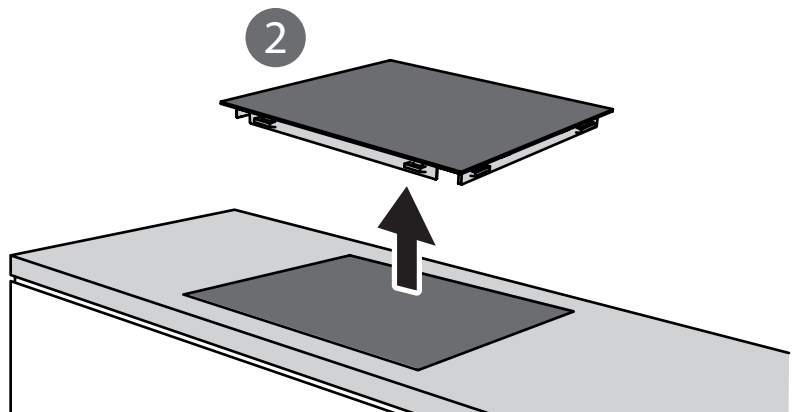
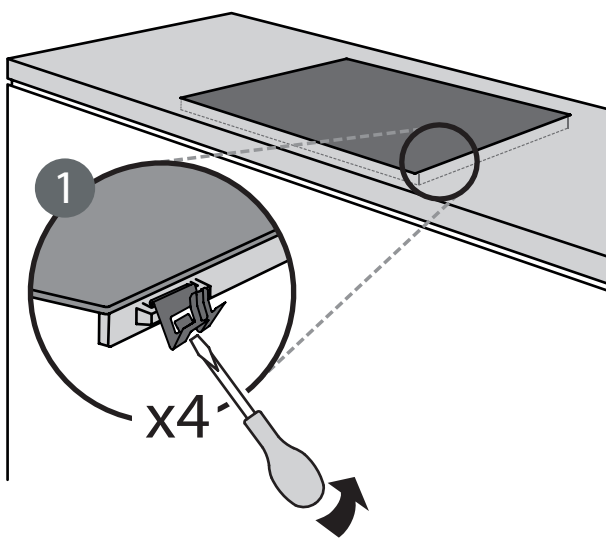
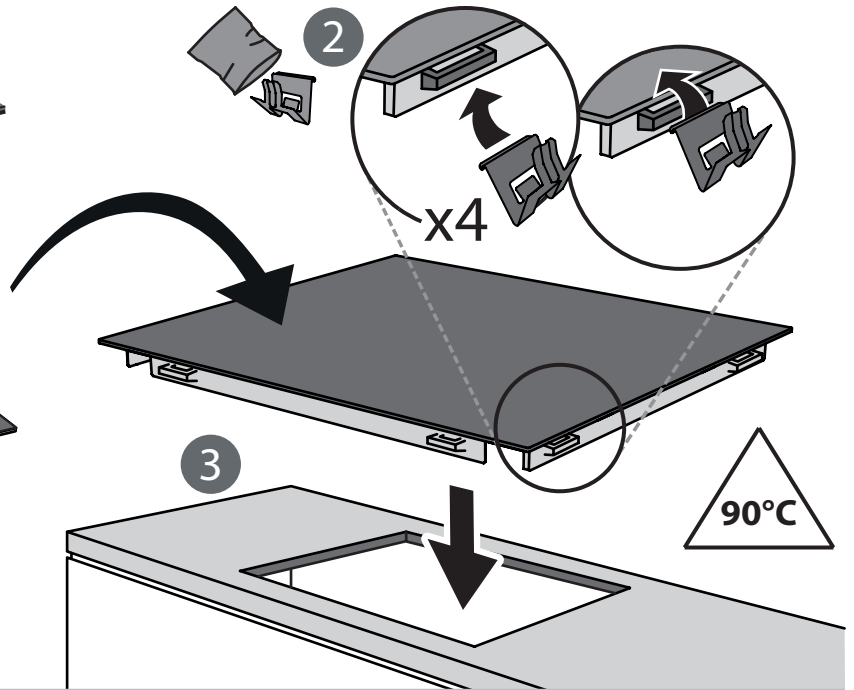
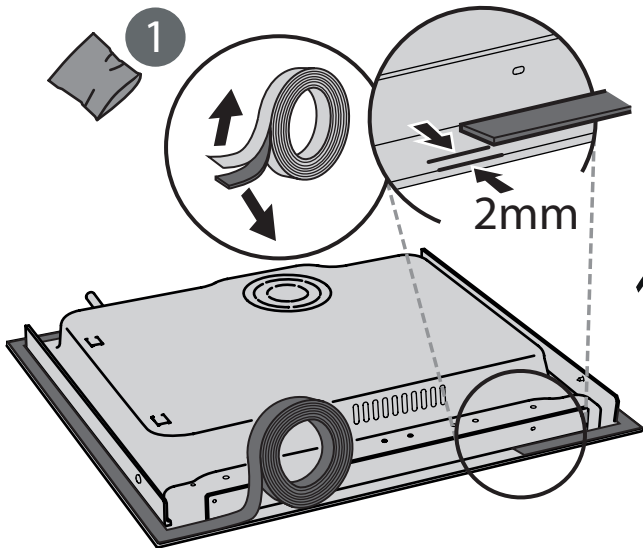
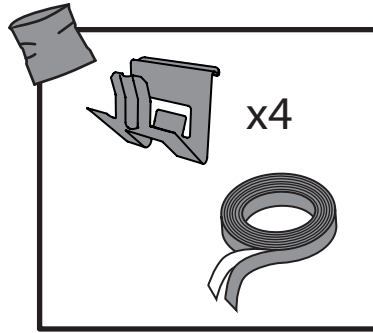
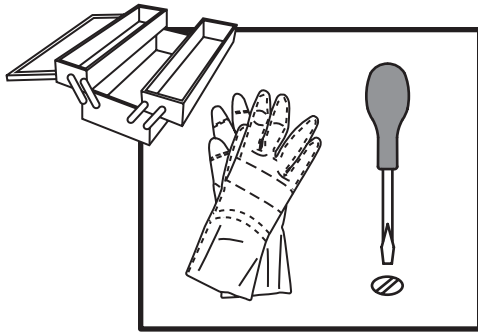

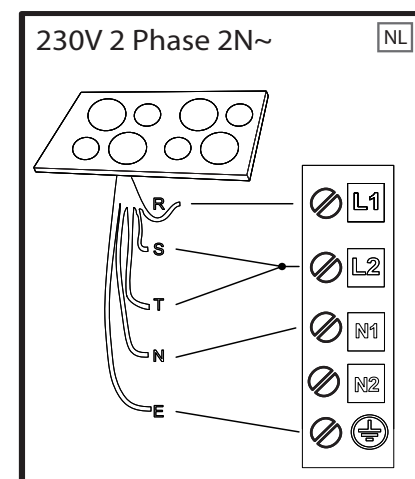
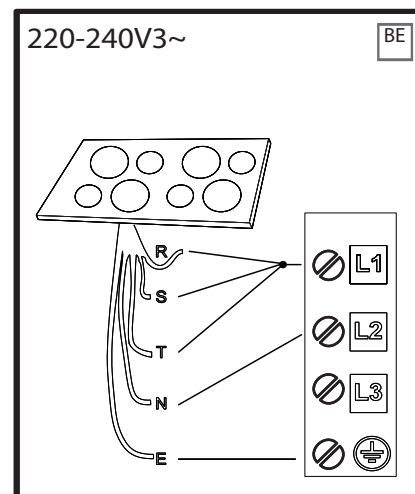
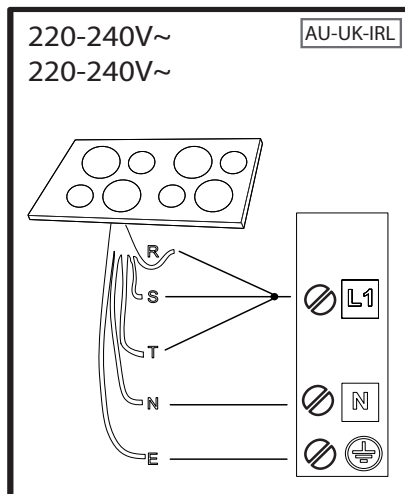
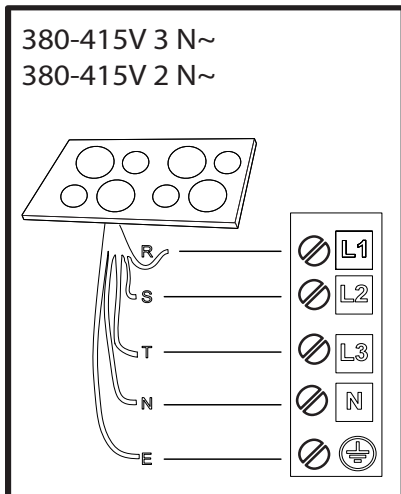

R

black-nero-negro-preto-μαύρος-must-melns-juodas-czarny-schwarz-noir-zwart-negru
черно-црн-črna-crno-черный-чорний-қара-černá-čierna-fekete-svart-musta-svart-sort
siyah-dubh

S

brown-marrone-marrón-marrom-кафэ-pruun-brūns-rudas-brązowy-braunen-brun-bruin
maro-кафяв-браон-rjava-smeđ-коричневый-қоңыр-hnědý-hnedý-barna
brunt-ruskea-brunt-brun-kahverengi-donn

T

blue (gray)-blu (grigio)-azul (gris)-azul (cinza)-μπλε (γκρι)-sinine (hall)-zila (pelēka)
mėlyna(pilkas)-niebieski (szary)-blau (grau)-bleu (gris)-blauw (grijs)-albastru (gri)
синьo (сивo)-плавa (сивa)-modro(sivo)-plava (siva)-синий (серый)-синий (сірий)
көк (сұр)-modrý (šedá)-modrý(sivá)-kék (szürke)-blå (grå)-sininen (harmaa)-blå (grå)
blåt (gråt)-mavi (gri)-gorm (liath)

 = **E**

yellow/green-giallo/verde-amarillo/verde-amarelo/verdekίτρο/πράσινο-kollane/roheline
dzeltens/zař-geltona/žalia-żółty/zielony-gelb/grün-jaune/vert-geel/groen-galben/verde
жълто/зелено-жyто/зелена-rumeno/zeleno-žuto/zelena-желтый/зеленый-gul/grønn
жовтий/зелений-жасыл/сары-žlutá/zelená-žltá/zelená-sárga/zöld-keltainen/vihreä
gul/grön-gul/grøn-sarı/yeşil-buı/glas

N

blue-blu-azul-azul-μπλε-sinine-zila-mėlyna-niebieski-blau-bleu-blauw-albastru-синьo
плавa-modro-plava-синий-синий-көк-modrý-modrý-kék-blå-sininen-blå-blåt-mavi-gorm



400011390766