

# ACM 868/BA/IXL

12NC: 859991011760

GTIN (EAN) code: 8003437832239

Whirlpool

SENSING THE DIFFERENCE

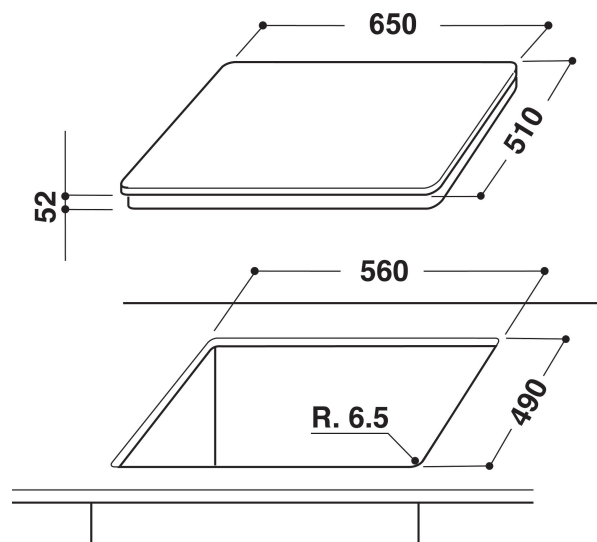

- iXelium treatment
- 6TH Sense Technology
- 4 induction cooking zones
- FlexiCook
- Residual heat indicator
- Child lock
- Warm keeping function
- On/Off Switch
- Simmering function
- 65 cm hob
- Timer
- Touch control for each cooking zone (Ulysse)
- Black Glass Hob
- 4 Boosters
- 4 Plate on Indicator
- Total power declared: 7.2 kW
- Power on indicator

## Whirlpool induction glass-ceramic hob - ACM 868/BA/IXL

4 induction rings. flexiCook zone technology, allowing you to combine multiple burners into a single cooking zone, for larger pots and pans. 6th SENSE technology, that allows you to automatically set the optimum temperature and power for simmering, melting or boiling, at the touch of a button. This Whirlpool induction glass-ceramic Hob features: An elegant technology, that heats the pan, not the hob, reducing energy dispersion and providing perfect cooking results. Electric power supply.



### iXelium

Long lasting shine. The revolutionary iXelium treatment protects your hob from scratches and corrosion, ensuring a perfect shine, always. And, it's easy to clean: all you need is water and a soft cloth.



### Power management

Outstanding energy efficiency. With the Power Management function, you set the hob's power level, to avoid the risk of overloading the power supply in your home.



### Booster

Enjoy super fast boiling times with the Booster cooking zone.



### 6TH SENSE

Enjoy ideal cooking results. 6TH SENSE automatically sets the ideal temperature and power for simmering, melting, or boiling, at the touch of a button.



### Flexible Cooking

Automatic power settings. Select the cooking function on your touch display and your hob will automatically adjust the power level accordingly.



### Keep warm

Warm meals, anytime. The low-powered Keep Warm function prevents your food from cooling, whilst the rest of the meal is being prepared.



### FlexiCook

Flexibility and performance. FlexiCook provides flexible cooking space for pots and pans of any size.



### Induction technology

Faster, energy-efficient cooking. Induction technology heats the pan, not the hob, reducing energy dispersion by 10%, and providing perfect cooking results.



### Direct Access

Intuitive design. The Direct Access front controls provide stunning, intuitive control over all of your hob's functions.

# ACM 868/BA/IXL

12NC: 859991011760

GTIN (EAN) code: 8003437832239

**Whirlpool**

SENSING THE DIFFERENCE

## MAIN FEATURES

|                                       |            |
|---------------------------------------|------------|
| Product group                         | Hob        |
| Construction type                     | Built-in   |
| Type of control                       | Electronic |
| Type of control settings              | -          |
| Number of gas burners                 | 0          |
| Number of electric cooking zones      | 4          |
| Number of electric plates             | 0          |
| Number of radiant plates              | 0          |
| Number of halogen plates              | 0          |
| Number of induction plates            | 4          |
| Number of electric warming zones      | 0          |
| Location of control panel             | Front      |
| Basic surface material                | Glass      |
| Main colour of product                | Black      |
| Electrical connection rating (W)      | 7200       |
| Gas connection rating (W)             | 0          |
| Current (A)                           | 31,3       |
| Voltage (V)                           | 230        |
| Frequency (Hz)                        | 50/60      |
| Length of Electrical Supply Cord (cm) | 120        |
| Plug type                             | No         |
| Gas connection                        | N/A        |
| Width of the product                  | 650        |
| Height of the product                 | 56         |
| Depth of the product                  | 510        |
| Minimum niche height                  | 30         |
| Minimum niche width                   | 560        |
| Niche depth                           | 490        |
| Net weight (kg)                       | 13.3       |
| Automatic programmes                  | No         |

## TECHNICAL FEATURES

|                         |                           |
|-------------------------|---------------------------|
| Power on indicator      | Yes                       |
| Number of indicators    | 4                         |
| Type of regulation      | Stepless energy regulated |
| Type of lid             | Without                   |
| Residual heat indicator | Separate                  |
| Main on/off switch      | Yes                       |
| Safety device           | -                         |
| Timer                   | Yes                       |

## PERFORMANCES

|              |          |
|--------------|----------|
| Energy input | Electric |
|--------------|----------|