

ART 1176/A++ SF

12NC: 856439296060

EAN code: 8003437040702



SENSING THE DIFFERENCE



MAIN FEATURES

Product group	Kombinovaná chladnička
Installation type	Built-in
Type of control	Electronic
Construction type	Built-in
Main colour of product	Nerez
Connection rating (W)	140
Current (A)	16
Voltage (V)	220-240
Frequency (Hz)	50
Number of compressors	1
Length of Electrical Supply Cord (cm)	245
Plug type	Schuko
Total unit net capacity (l)	275
Star Rating	4
Height of the product	1770
Width of the product	540
Depth of the product	545
Maximum adjustability feet	0
Net weight (kg)	50.60

TECHNICAL FEATURES

Defrost process fridge section	Automatic
Defrost process freezer section	Manual
Fast cooling switch	Ano
Fast freezing function	Ne
Door opened indicator freezer	Ne
Temperature adjustable	Ano
Temperature adjustable freezer	Ne
Interior ventilator fridge section	Ano
Number of freezing drawers	3
Automatic motor-driven ice-maker	N/A
Number of shelves in fridge compartment	5
Material of the shelves	Glass With Profile
Thermometer fridge section	None
Thermometer freezer section	None
Number of temperature zones	2

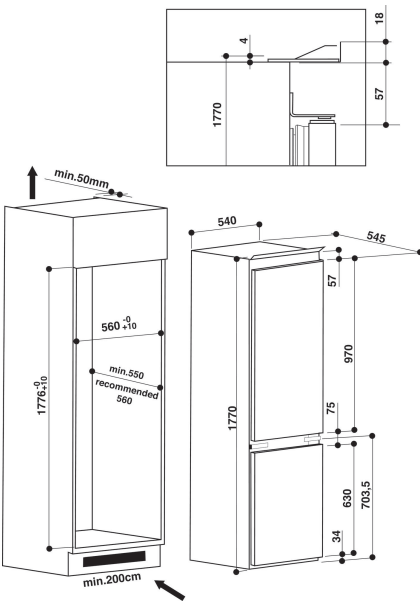

ENERGETICKÝ ŠTÍTEK

Energy efficiency class - NEW (2010/30/EC)	A++
Energy consumption annual (kWh/annum) - NEW (2010/30/EC)	235
Refrigerator Net capacity (l) - NEW (2010/30/EC)	195
Freezer Net capacity (l) - NEW (2010/30/EC)	80
Freezing capacity (kg/24h) - NEW (2010/30/EC)	3.50
Climate class	SN-T
Noise level (dB(A) re 1 pW)	35
Frost free system	Ne