

ART 920/A+

12NC: 856499196000

EAN code: 8003437039409



SENSING THE DIFFERENCE

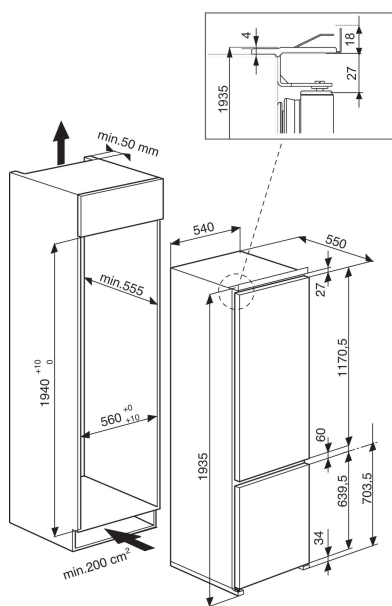

MAIN FEATURES

Product group	Kombinovaná chladnička
Installation type	Built-in
Type of control	Electronic
Construction type	Built-in
Main colour of product	White
Connection rating (W)	0
Current (A)	15
Voltage (V)	220-240
Frequency (Hz)	50-60
Number of compressors	1
Length of Electrical Supply Cord (cm)	245
Plug type	Schuko
Total unit net capacity (l)	310
Star Rating	4
Height of the product	1935
Width of the product	540
Depth of the product	550
Maximum adjustability feet	0
Net weight (kg)	56

TECHNICAL FEATURES

Defrost process fridge section	Automatic
Defrost process freezer section	Manual
Fast cooling switch	Ano
Fast freezing function	N/A
Door opened indicator freezer	N/A
Temperature adjustable	-
Temperature adjustable freezer	Ne
Interior ventilator fridge section	Ano
Number of freezing drawers	3
Automatic motor-driven ice-maker	N/A
Number of shelves in fridge compartment	5
Material of the shelves	Glass With Profile
Thermometer fridge section	None
Thermometer freezer section	N/A
Number of temperature zones	1

ENERGETICKÝ ŠTÍTEK

Energy efficiency class - NEW (2010/30/EC)	A+
Energy consumption annual (kWh/annum) - NEW (2010/30/EC)	311
Refrigerator Net capacity (l) - NEW (2010/30/EC)	237
Freezer Net capacity (l) - NEW (2010/30/EC)	73
Freezing capacity (kg/24h) - NEW (2010/30/EC)	3.50
Climate class	SN-T
Noise level (dB(A) re 1 pW)	35
Frost free system	Ne