

MWH 222.1 X

12NC: F082009

GTIN (EAN) code: 5016108820094

Hotpoint

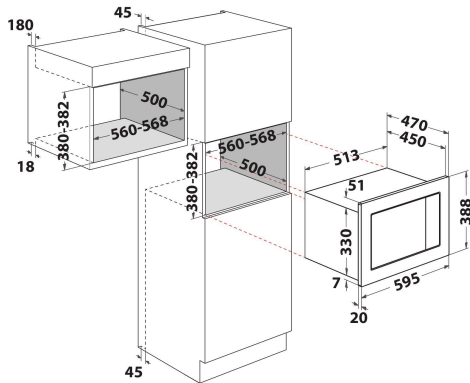

MAIN FEATURES

Product group	Microwave
Commercial code	MWH 222.1 X
Main colour of product	Stainless steel
Type of micro-wave oven	MW+Grill function
Construction type	Built-in
Type of control	Electronic
Type of control settings	Buttons + leds
Additional cooking method Grill	Yes
Crisp	No
Steam	No
Additional cooking method Fan cooking	No
Clock	Yes
Automatic programmes	Yes
Height of the product	388
Width of the product	595
Depth of the product	400
Minimum niche height	360
Minimum niche width	560
Niche depth	500
Net weight (kg)	19.7
Cavity capacity (l)	25
Turntable	Yes, stoppable
Turntable diameter (mm)	300
Integrated Cleaning system	No

TECHNICAL FEATURES

Current (A)	13
Voltage (V)	230
Frequency (Hz)	50
Length of Electrical Supply Cord (cm)	110
Plug type	UK
Timer	Yes
Grill power (W)	0
Type of grill	Heating element
Cavity material	Stainless steel
Interior light	Yes
Additional cooking method Grill	Yes
Position of interior lights of the cavity	-

PERFORMANCES

6th Sense / Dynamic Intelligence	No
Number of power levels	5
Maximum micro-wave power (W)	900
Bread defrost	No
Jet defrost	No
Jet start	No