

ADGU 941 IX

12NC: 851121701000

EAN code: 8003437216374

Whirlpool

SENSING THE DIFFERENCE

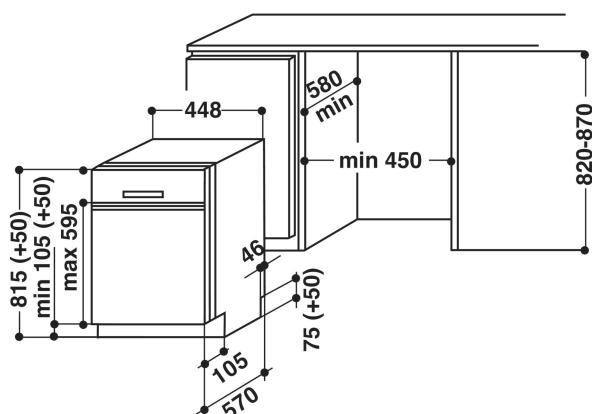

MAIN FEATURES

Construction type	Vstavaná
Installation type	Vstavaná s panelom
Type of control	Mechanical and electronic
Type of control setting and signalling devices	-
Removable work top	N/A
Door decor panel	N/A
Main colour of product	Nerez
Connection rating (W)	1930
Current (A)	10
Voltage (V)	220-240
Frequency (Hz)	50
Length of Electrical Supply Cord (cm)	150
Plug type	Schuko
Length inlet hose (cm)	150
Length outlet hose (cm)	160
Adjustable plinth	Nie
Height of removable worktop (mm)	0
Adjustable feet	Yes - front only
Height of the product	815
Width of the product	448
Depth of the product	550
Depth with open door 90 degree (mm)	-
Minimum niche height	870
Maximum niche height	820
Minimum niche width	450
Maximum niche width	580
Niche depth	580
Net weight (kg)	37.50
Gross weight (kg)	42.50

TECHNICAL FEATURES

Automatic programmes	Áno
Maximum temperature for water intake (°C)	60
Start delay options	Continuous
Start delay time max. (h)	24
Progress indicator	-
change to:	Áno
Salt light indicator	Áno
Rinse aid light indicator	Áno
Safety device	Áno
Adjustable upper basket	Yes, unloaded
Largest loadable dish upper basket (cm)	0
Largest loadable dish lower basket (cm)	0

ENERGETICKÝ ŠTÍTK

Energy efficiency class - NEW (2010/30/EC)	A++
Energy consumption annual (kWh/annum) - NEW (2010/30/EC)	211
Duration of the left-on mode - NEW (2010/30/EC)	160
Power consumption in left-on mode - NEW (2010/30/EC)	0.49
Power consumption in off-mode - NEW (2010/30/EC)	0.49
Water consumption annual (l/annum) - NEW (2010/30/EC)	2380
Noise level (dB(A) re 1 pW)	45