

HM 325 FF.2

12NC: F103124

GTIN (EAN) code: 5054645031245

Hotpoint

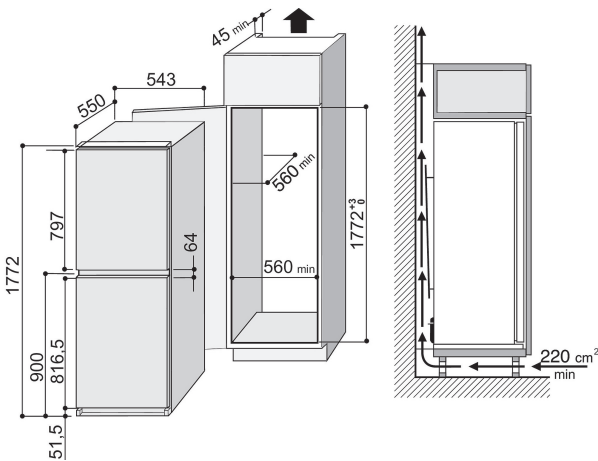

MAIN FEATURES

| | |
|---------------------------------------|----------------------------|
| Product group | Fridge/freezer combination |
| Installation type | Free-standing |
| Type of control | Mechanical |
| Construction type | Built-in |
| Main colour of product | White |
| Electrical connection rating (W) | 0 |
| Current (A) | 0,5 |
| Voltage (V) | 220-240 |
| Frequency (Hz) | 50 |
| Number of compressors | 1 |
| Length of Electrical Supply Cord (cm) | 220 |
| Plug type | UK |
| Total unit net capacity (l) | 225 |
| Star Rating | 4 |
| Height of the product | 1740 |
| Width of the product | 545 |
| Depth of the product | 580 |
| Maximum adjustability feet | 0 |
| Net weight (kg) | 56 |

TECHNICAL FEATURES

| | |
|---|------------|
| Defrost process fridge section | Automatic |
| Defrost process freezer section | Frost-free |
| Fast cooling possibility | No |
| Fast freezing function | Yes |
| Door opened indicator freezer | No |
| Temperature adjustable | Yes |
| Temperature adjustable freezer | No |
| Interior ventilator fridge section | No |
| Number of freezing drawers | 4 |
| Automatic motor-driven ice-maker | N/A |
| Number of shelves in fridge compartment | 3 |
| Material of the shelves | Glass |
| Thermometer fridge section | None |
| Thermometer freezer section | None |
| Number of temperature zones | N/A |

PERFORMANCES

| | |
|--|--------------------|
| Energy efficiency class - NEW (2010/30/EU) | A+ |
| Energy consumption annual (kWh/annum) - NEW (2010/30/EU) | 288 |
| Refrigerator Net capacity (l) - NEW (2010/30/EU) | 147 |
| Freezer Net capacity (l) - NEW (2010/30/EU) | 76 |
| Freezing capacity (kg/24h) - NEW (2010/30/EU) | 3.5 |
| Climate class | SN-N-ST-T |
| Noise level (dB(A) re 1 pW) | 42 |
| Frost free system | Fridge and freezer |