

AKT 108/IX

12NC: 859410801010

EAN code: 8003437812675

Whirlpool

SENSING THE DIFFERENCE

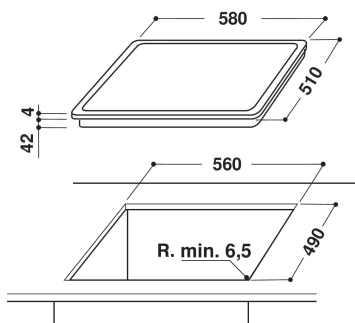
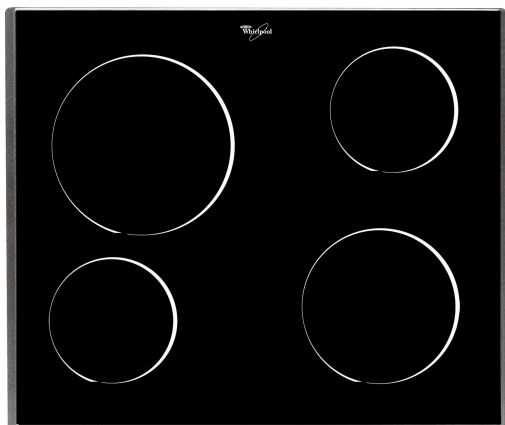

MAIN FEATURES

Product group	Hob
Construction type	Built-in
Type of control	Mechanical
Type of control setting and signalling devices	-
Number of gas burners	0
Number of electric cooking zones	4
Number of electric plates	0
Number of radiant plates	4
Number of halogen plates	0
Number of induction plates	0
Number of electric warming zones	0
Location of control panel	External control
Basic surface material	Glass
Main colour of product	Black
Electrical connection rating (W)	6200
Gas connection rating (W)	0
Current (A)	27
Voltage (V)	230
Frequency (Hz)	50
Length of Electrical Supply Cord (cm)	-
Plug type	Ne
Gas connection	-
Width of the product	580
Height of the product	46
Depth of the product	510
Minimum niche height	38
Minimum niche width	560
Niche depth	490
Net weight (kg)	8.50
Automatic programmes	Ne

TECHNICAL FEATURES

Power on indicator	Ne
Plate on indicator	0
Type of regulation	Radiant
Type of lid	-
Residual heat indicator	without
Main on/off switch	Ne
Safety device	-
Timer	Ne

ENERGY LABEL

Energy input

Electric