

# ADG 8675 A+ FD

12NC: 854286701050

EAN code: 8003437241949



SENSING THE DIFFERENCE

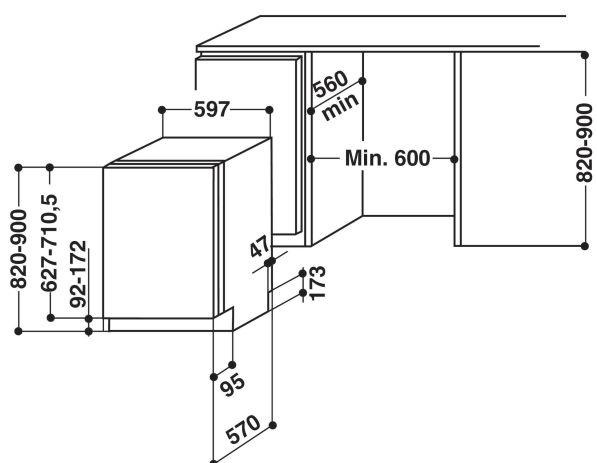

## MAIN FEATURES

|  |                           |
|--|---------------------------|
| Construction type                              | Built-in                  |
| Installation type                              | Plne vestavná             |
| Type of control                                | Mechanical and electronic |
| Type of control setting and signalling devices | 7 segments                |
| Removable work top                             | Ne                        |
| Door decor panel                               | N/A                       |
| Main colour of product                         | Black                     |
| Connection rating (W)                          | 2200                      |
| Current (A)                                    | 10                        |
| Voltage (V)                                    | 220-230                   |
| Frequency (Hz)                                 | 50                        |
| Length of Electrical Supply Cord (cm)          | 150                       |
| Plug type                                      | Schuko                    |
| Length inlet hose (cm)                         | 160                       |
| Ledningslængde (cm)                            | 200                       |
| Adjustable plinth                              | Ne                        |
| Height of removable worktop (mm)               | 0                         |
| -  | Yes - all                 |
| Height of the product                          | 820                       |
| Width of the product                           | 597                       |
| Depth of the product                           | 555                       |
| Depth with open door 90 degree (mm)            | 1150                      |
| Minimum niche height                           | 820                       |
| Maximum niche height                           | 900                       |
| Minimum niche width                            | 600                       |
| Maximum niche width                            | 600                       |
| Niche depth                                    | 570                       |
| Net weight (kg)                                | 41                        |
| Gross weight (kg)                              | 42.2                      |

## TECHNICAL FEATURES

|   |            |
|---|------------|
| Automatic programmes                      | Ano        |
| Maximum temperature for water intake (°C) | 60         |
| Start delay options                       | Continuous |
| Start delay time max. (h)                 | 24         |
| Progress indicator                        | Ano        |
| Digital countdown indicator               | Ano        |
| Salt light indicator                      | Ano        |
| Rinse aid light indicator                 | Ano        |
| Safety device                             | N/A        |
| Adjustable upper basket                   | Ano        |
| Largest loadable dish upper basket (cm)   | 0          |
| Largest loadable dish lower basket (cm)   | 0          |

## ENERGETICKÝ ŠTÍTEK

|  |      |
|--|------|
| Energy efficiency class - NEW (2010/30/EC)               | A+   |
| Energy consumption annual (kWh/annum) - NEW (2010/30/EC) | 293  |
| Duration of the left-on mode - NEW (2010/30/EC)          | 3    |
| Power consumption in left-on mode - NEW (2010/30/EC)     | 0.7  |
| Power consumption in off-mode - NEW (2010/30/EC)         | 0.4  |
| Water consumption annual (l/annum) - NEW (2010/30/EC)    | 2660 |
| Noise level (dB(A) re 1 pW)                              | 44   |