

HM 325 FF 0

12NC: 869991615310

GTIN (EAN) code: 5054645615315

Hotpoint

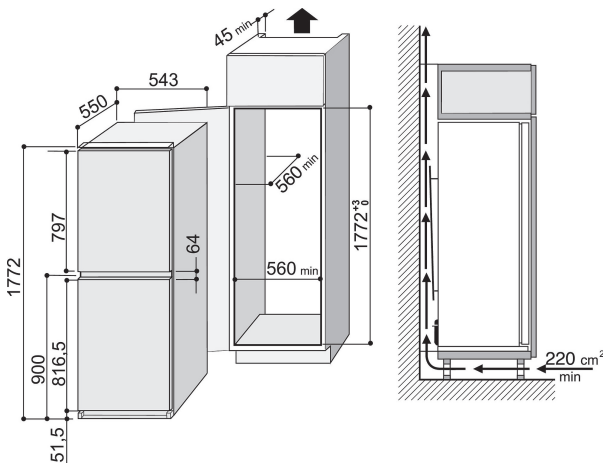

MAIN FEATURES

Product group	Fridge/freezer combination
Installation type	Free-standing
Type of control	Mechanical
Construction type	Built-in
Main colour of product	White
Electrical connection rating (W)	0
Current (A)	0,5
Voltage (V)	220-240
Frequency (Hz)	50
Length of Electrical Supply Cord (cm)	220
Plug type	UK
Total volume of the product (EU 2017/1369)	223
Star Rating	4
Height of the product	1740
Width of the product	545
Depth of the product	580
Maximum adjustability feet	0
Net weight (kg)	56

TECHNICAL FEATURES

Defrost process fridge section	Automatic
Defrost process freezer section	Frost-free
Fast cooling possibility	No
Fast freezing function (EU 2017/1369)	Yes
Door opened indicator freezer	No
Temperature adjustable	Yes
Temperature adjustable freezer	No
Interior ventilator fridge section	No
Number of freezing drawers	4
Number of shelves in fridge compartment	3
Material of the shelves	Glass
Number of temperature zones	N/A

PERFORMANCES

Energy Efficiency Class (Regulation (EU) 2017/1369)	G
Annual energy consumption in kilowatt hour per year (kWh/a) (EU) 2017/1369	288
The sum of the volumes of the chill compartments and the unfrozen compartments (EU 2017/1369)	147
The sum of the volumes of the frozen compartments (EU 2017/1369)	76
Freezing Capacity (kg/24h) (4-star Compartment) (EU2017/1369)	7,5
Climate Class (EU) 2017/1369	temperate/ subtropical
Airborne acoustical noise emissions (EU 2017/1369)	42
Airborne acoustical noise emission class (EU 2017/1369)	D
Frost free system	Fridge and freezer