

Hotpoint

FRENCH DOOR BOTTOM MOUNT REFRIGERATOR USE AND CARE GUIDE

Table of Contents

REFRIGERATOR SAFETY	4
Proper Disposal of Your Old Refrigerator	8
PARTS AND FEATURES	9
WHAT'S NEW BEHIND THE DOORS?	10
INSTALLATION INSTRUCTIONS	11
Getting Started.....	11
Water Filter Installation	11
Unpack the Refrigerator	11
Location Requirements.....	12
Electrical Requirements	12
Remove and Replace Refrigerator Doors	14
Remove and Replace Freezer/Flexi Freeze Door.....	16
Refrigerator Levelling	17
Water Supply Requirements	17
Connect the Water Supply.....	17
FILTERS AND ACCESSORIES	19
Water Filtration System.....	19
Accessories.....	20
Assistance or Service	20
USING THE CONTROLS	21
Lighting the Refrigerator	23
REFRIGERATOR CONNECTIVITY FEATURES	23
CONNECTIVITY SETUP	24
Automatic Set-Up Instructions — Wi-Fi Protected Setup (WPS).....	24
Water and Ice Dispensers.....	25
REFRIGERATOR USE	27
Opening and Closing Doors	27
Ice Maker and Storage Bin	28
SHELVES, BINS, AND DRAWERS	29
Freezer Storage Compartments	30
Cleaning	31
Lights.....	31
Holiday and Moving Care	31
TROUBLESHOOTING - CONNECTED MODELS	33
TROUBLESHOOTING	35
PERFORMANCE DATA SHEET	41

REFRIGERATOR SAFETY

Your safety and the safety of others are very important.

We have provided many important safety messages in this manual and on your appliance. Always read and obey all safety messages.



This is the safety alert symbol.

This symbol alerts you to potential hazards that can kill or hurt you and others.

All safety messages will follow the safety alert symbol and either the word "DANGER" or "WARNING."

These words mean:

⚠ DANGER

You can be killed or seriously injured if you don't immediately follow instructions.

⚠ WARNING

You can be killed or seriously injured if you don't follow instructions.

All safety messages will tell you what the potential hazard is, tell you how to reduce the chance of injury, and tell you what can happen if the instructions are not followed.

SAFETY INSTRUCTIONS

IMPORTANT TO BE READ AND OBSERVED

Before using the appliance, read these safety instructions. Keep them nearby for future reference. These instructions and the appliance itself provide important safety warnings, to be observed at all times. The manufacturer declines any liability for failure to observe these safety instructions, for inappropriate use of the appliance or incorrect setting of controls.

△ Very young children (0-3 years) should be kept away from the appliance. Young children (3-8 years) should be kept away from the appliance unless continuously supervised. Children from 8 years old and above and persons with reduced physical, sensory or mental capabilities or lack of experience and knowledge can use this appliance only if they are supervised or have been given instructions on safe use and understand the hazards involved. Children must not play with the appliance. Cleaning and user maintenance must not be carried out by children without supervision. Children aged from 3 to 8 years are allowed to load and unload refrigerating appliances.

PERMITTED USE

△ CAUTION: The appliance is not intended to be operated by means of an external switching device, such as a timer, or separate remote controlled system.

△ This appliance is intended to be used in household and similar applications such as: staff kitchen areas in shops, offices and other working environments; farm houses; by clients in hotels, motels, bed & breakfast and other residential environments.

△ This appliance is not for professional use. Do not use the appliance outdoors.

△ The bulb used inside the appliance is specifically designed for domestic appliances and is not suitable for general room lighting within the home (EC Regulation 244/2009).

△ The appliance is designed for operation in places where the ambient temperature comes within the following ranges, according to the climatic class given on the rating plate. The appliance may not work properly if it is left for a long time at a temperature outside the specified range.

Climatic Class Amb. T. (°C)

SN: From 10 to 32 °C; N: From 16 to 32 °C

ST: From 16 to 38 °C; T: From 16 to 43 °C

△ This appliance does not contain CFCs. The refrigerant circuit contains R600a (HC). Appliances with Isobutane (R600a): isobutane is a natural gas without environmental impact, but is flammable. Therefore, make sure the refrigerant circuit pipes are not damaged, especially when emptying the refrigerant circuit.

△ WARNING: Do not damage the appliance refrigerant circuit pipes.

△ WARNING: Keep ventilation openings, in the appliance enclosure or in the built-in structure, clear of obstruction.

△ WARNING: Do not use mechanical, electric or chemical means other than those recommended by the Manufacturer to speed up the defrost process.

△ WARNING: Do not use or place electrical devices inside the appliance compartments if they are not of the type expressly authorized by the Manufacturer.

△ WARNING: Ice makers and/or water dispensers not directly connected to the water supply must be filled with potable water only.

△ WARNING: Automatic ice-makers and/or water dispensers must be connected to a water supply that delivers potable water only, with mains water pressure between 0.14Mpa and 1.0Mpa (1.4 bar and 10 bar).

△ WARNING: Use the new hose-sets supplied with the appliance, and the old hose-sets should not be reused.

△ Do not store explosive substances such as aerosol cans with a flammable propellant in this appliance.

△ Do not swallow the contents (non-toxic) of the ice packs (provided with some models). Do not eat ice cubes or ice lollies immediately after taking them out of the freezer since they may cause cold burns.

△ For products designed to use an air filter inside an accessible fan cover, the filter must always be in position when the refrigerator is in function.

△ Do not store glass containers with liquids in the freezer compartment since they may break. Do not obstruct the fan (if included) with food items. After placing the food check that the door of the compartments closes properly, especially the freezer door.

△ Damaged gaskets must be replaced as soon as possible.

△ Use the refrigerator compartment only for storing fresh food and the freezer compartment only for storing frozen food, freezing fresh food and making ice cubes.

△ Avoid storing unwrapped food in direct contact with internal surfaces of the fresh food or freezer compartments. Appliances could have special compartments (Fresh Food Compartment, Zero Degree Box, etc.). Unless specified in the specific booklet of product, they can be removed, maintaining equivalent performances.

△ Avoid a direct contact between the fresh food and the food that is already frozen. To optimize the freezing speed, drawers can be removed and the food can be placed directly on the bottom or top of the compartment.

△ Warning: Risk of fire/flammable materials. The most appropriate compartments of the appliance where specific types of food are to be stored, taking into account different temperature distribution in different compartments in the appliance, are as follows:

- Refrigerator compartment: Store tropical fruit,

cans, drinks, eggs, sauces, pickles, butter, jam, cheese, milk, dairy food, yoghurt. You may also store cold cuts, desserts, meat and fish, cheesecake, fresh pasta, sour cream, pudding and cream cheese.

Fruit & vegetable drawer at the bottom of the refrigerator compartment: Store vegetables and fruits (excluding tropical fruits).

Chiller compartment: Only store meat and fish in the coldest drawer

- Freezer compartment:

is suitable for freezing foodstuffs from ambient temperature and for storing frozen food as the temperature is evenly distributed throughout the entire compartment. Purchased frozen food has the storage expiration date stated on the packaging. This date takes into account the type of food being stored and therefore this date should be respected. Fresh food should be stored for the following time periods: 1-3 months for cheese, shellfish, ice cream, ham/sausage, milk, fresh liquids; 4 months for steak or chops (beef, lamb, pork); 6 months for butter or margarine, poultry (chicken, turkey); 8-12 months for fruits (except citrus), roast meat (beef, pork, lamb), vegetables. Expiration dates on the packaging of foods must be respected. Please store foodstuffs according to above paragraphs for best preservation over the longest period, to avoid food waste.

To avoid food contamination, please observe the following:

- Opening the door for long periods can cause a significant increase of the temperature in the compartments of the appliance.

- Regularly clean surfaces that may come into contact with food and accessible drainage systems.

- Clean water tanks if they have not been used for 48 h; flush the water system connected to a water supply if water has not been drawn for 5 days.

- Store raw meat and fish in suitable containers in the refrigerator, so that it does not come into contact with or drip onto other food.

In the Convertible Space storage should be as followed:

+10°C : store white wine

+4°C: store vegetables and fruits (excluding tropical fruits)

0°C: only store meat and fish

All set points below zero: store frozen foodstuff as for freezer cavity

- Two-star frozen food compartments are suitable for storing pre-frozen food, storing or making ice cream and ice cubes.

- Do not freeze fresh food in one, two or three-star compartments.

- If the refrigerating appliance is left empty for long periods, switch off, defrost, clean, dry, and leave the door open to prevent mould developing inside the appliance.

INSTALLATION

⚠ The appliance must be handled and installed by two or more persons - risk of injury. Use protective gloves to unpack and install - risk of cuts.

⚠ Installation, including water supply (if any) and electrical connections, and repairs must be carried out by a qualified technician. Do not repair or replace any part of the appliance unless specifically stated in the user manual. Keep children away from the installation site.

After unpacking the appliance, make sure that it has not been damaged during transport. In the event of problems, contact the dealer or your nearest After-sales Service. Once installed, packaging waste (plastic, styrofoam parts etc.) must be stored out of reach of children - risk of suffocation. The appliance must be disconnected from the power supply before any installation operation - risk of electric shock. During installation, make sure the appliance does not damage the power cable - risk of fire or electric shock. Only activate the appliance when the installation has been completed.

⚠ Be careful not to damage the floors (e.g. parquet) when moving the appliance. Install the appliance on a floor or support strong enough to take its weight and in a place suitable for its size and use. Make sure the appliance is not near a heat source and that the four feet are stable and resting on the floor, adjusting them as required, and check that the appliance is perfectly level using a spirit level. Wait at least two hours before switching the appliance on, to ensure that the refrigerant circuit is fully efficient.

⚠ WARNING: When positioning the appliance, ensure the supply cord is not trapped or damaged.

⚠ WARNING: To avoid a hazard due to instability, positioning or fixing of the appliance must be done in accordance with the manufacturer instructions. It is forbidden to place the refrigerator in such way that the metal hose of gas stove, metal gas or water pipes, or electrical wires are in contact with the refrigerator back wall (condenser coil).

⚠ To guarantee adequate ventilation, leave a space on both sides and above the appliance. The distance between the rear of the appliance and the wall behind the appliance should be 50mm, to avoid access to hot surfaces. A reduction of this space will increase the Energy consumption of product.

⚠ If it is necessary to replace the doors, please contact the Technical Assistance Center.

⚠ An 'Approved' single check valve or some other no less effective backflow prevention device providing backflow prevention protection to at least fluid category two shall be fitted at the point of connection(s) between the water supply and the fitting or appliance.

FOR AUSTRALIA ONLY: A backflow device WaterMark approved (not included, responsibility of the plumbing) is required to be installed upstream in accordance with the WaterMark certification and in accordance to AS/NZS 3500.1.2 and complying with AS/NZS 2845.1.

ELECTRICAL WARNINGS

⚠ It must be possible to disconnect the appliance from the power supply by unplugging it if plug is accessible, or by a multi-pole switch installed upstream of the socket in accordance with the wiring rules and the appliance must be earthed in conformity with national electrical safety standards.

⚠ Do not use extension leads, multiple sockets or adapters. The electrical components must not be accessible to the user after installation. Do not use the appliance when you are wet or barefoot. Do not operate this appliance if it has a damaged power cable or plug, if it is not working properly, or if it has been damaged or dropped.

⚠ If the supply cord is damaged, it must be replaced with an identical one by the manufacturer, its service agent or similarly qualified persons in order to avoid a hazard-risk of electric shock.

⚠ **WARNING:** Do not locate multiple portable socket-outlets or portable power supplies at the rear of the appliance.

CLEANING AND MAINTENANCE

⚠ **WARNING:** Ensure that the appliance is switched off and disconnected from the power supply before performing any maintenance operation; never use steam cleaning equipment - risk of electric shock.

⚠ Do not use abrasive or harsh cleaners such as window sprays, scouring cleansers, flammable fluids, cleaning waxes, concentrated detergents, bleaches or cleansers containing petroleum products on plastic parts, interior and door liners or gaskets. Do not use paper towels, scouring pads, or other harsh cleaning tools.

DISPOSAL OF PACKAGING MATERIALS

The packaging material is 100% recyclable and is marked with the recycle symbol ♻.

The various parts of the packaging must therefore be disposed of responsibly and in full compliance with local authority regulations governing waste disposal.

DISPOSAL OF HOUSEHOLD APPLIANCES

This appliance is manufactured with recyclable or reusable materials. Dispose of it in accordance with local waste disposal regulations. For further information on the treatment, recovery and recycling of household electrical appliances, contact your local authority, the collection service for household waste or the store where you purchased the appliance. This appliance is marked in compliance with European Directive 2012/19/EU, Waste Electrical and Electronic Equipment (WEEE). By ensuring this product is disposed of correctly, you will help prevent negative consequences for the environment and human health. The symbol  on the product or on the accompanying documentation indicates that it should not be treated as domestic waste but must be taken to an appropriate collection center for the recycling of electrical and electronic equipment.

ENERGY SAVING TIPS

Install the appliance in a dry, well ventilated room far away from any heat source (eg. radiator, cooker, etc.) and in a place not exposed directly to the sun. If required, use an insulating plate. To guarantee adequate ventilation follow installation instructions.

Insufficient ventilation at the back of the product increases energy consumption and decreases cooling efficiency. Frequent door opening might cause an increase in Energy Consumption. The internal temperature of the appliance and the Energy Consumption may be affected also by the ambient temperature, as well as location of the appliance. Temperature setting should take into consideration these factors.

Reduce door opening to a minimum.

When thawing frozen food, place in the refrigerator. The low temperature of the frozen products cools the food in the refrigerator. Allow warm food and drinks to cool down before placing in the appliance.

Positioning of the shelves in the refrigerator has no impact on the efficient usage of energy. Food should be placed on the shelves in such way to ensure proper air circulation (food should not touch each other and distance between food and rear wall should be kept).

You can increase storage capacity of frozen food by removing baskets and, if present, Stop Frost shelf.

Do not worry about noises coming from the compressor which are described as normal noises in this product's Quick Guide.

FROZEN COMPARTMENT

Product	Storage period (-12°C)	Recommended Storage period (-18°C)	Storage period (-22°C)
Butter or margarine	1 month	6 months	9 months
Fish	1 month	1-3 months	6 months
Fruits (except citrus) & Vegetables	1 month	8-12 months	12 months
Meat- Ham- sausage Roasts (beef-pork- lamb) Steaks or chops (beef-lamb-pork)	1 month	2 months 8-12 months 4 months	12 months
Milk, Fresh fluid, Cheese, Ice cream or sherbet	1 month	1-3 months	5 months
Poultry (chicken-turkey)	1 month	5-7 month	9 months

UNFROZEN COMPARTMENT

Product	Storage period (0-3°C)	Recommended Storage period (3-6°C)	Storage period 6-8°C
cans, drinks, eggs, sauces, pickles, butter, jam	3-4 weeks	3-4 weeks	3-4 weeks
Tropical fruit	Not recommended	2-4 weeks	3-4 weeks
cheese, milk, dairy food, deli food, yoghurt	2-5 days	2-5 days	2-5 days
Cold cuts, desserts, meat and fish and home-cooked food	3-5 days	1-2 days	Not recommended
Store vegetables and fruits (excluding tropical fruits and citrus)	15 days	10-12 days	4-7 days

NOTE: Flexi freezer Please refer to applicable instruction of "FROZEN COMPARTMENT" and "UNFROZEN COMPARTMENT". This table is only suitable for European Union countries.

The model information can be retrieved using the QR-Code reported in the energy label. The label also includes the model identifier that can be used to consult the portal of the registry at <https://eprel.ec.europa.eu>.



Proper Disposal of Your Old Refrigerator

DANGER : Risk of child entrapment. Before you throw away your old refrigerator or freezer:

- Take off the doors.
- Leave the shelves in place so that children cannot easily climb inside.

⚠ WARNING

Suffocation Hazard

Remove doors from your old refrigerator.

Failure to do so can result in death or brain damage.

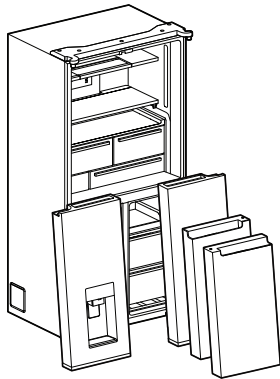

IMPORTANT: Child entrapment and suffocation are not problems of the past. Scrapped or abandoned refrigerators are still dangerous—even if they will sit for “just a few days.” If you are getting rid of your old refrigerator, please follow these instructions to help avoid accidents.

Important information to know about disposal of refrigerants:

Dispose of refrigerator in accordance with Federal and Local regulations. Refrigerants must be evacuated by a licensed, EPA certified refrigerant technician in accordance with established procedures.

PARTS AND FEATURES

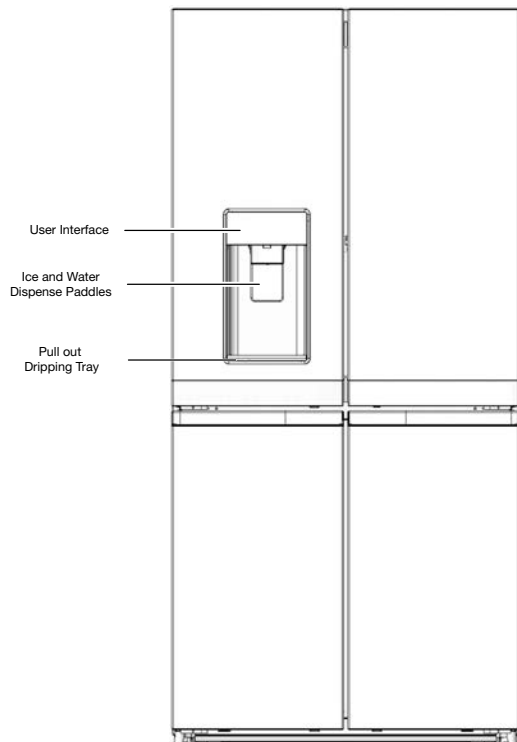
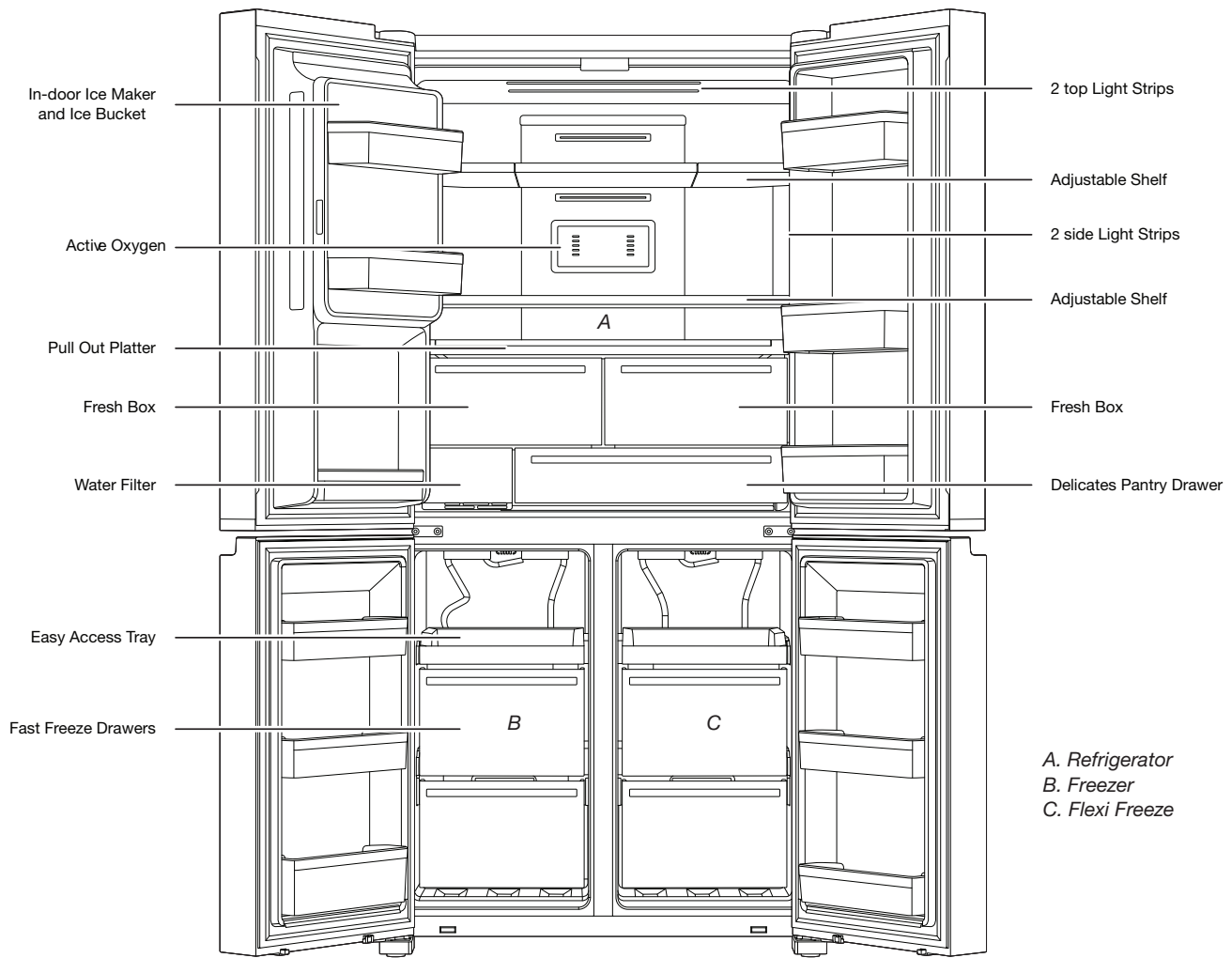

NOTE:

The drawers, baskets and shelves shall remain in the position like the above picture. This is the best condition for energy consumption. This refrigerating appliance is not intended to be used as a built-in appliance.

When you first install your refrigerator, make sure that the controls are still set to the recommended set points. The factory recommended set points are 3°C for the refrigerator and -18°C for the freezer. All the LED lights in this product are energy efficiency class G. Load limits are determined by baskets, flaps, drawers, shelves etc. Make sure that these components can still close easily after loading.

Storage Capacity:

Please check the rating label in the back of the product.

WHAT'S NEW BEHIND THE DOORS?

In-Door-Ice® Storage Bin

The ice maker and ice storage bin are located in the door for easy access to filtered ice while freeing up valuable shelf space inside and adding additional door bins for more usable space.

Freeze Shield

This feature minimizes moisture migration in the frozen food and reduces the freezer burn occurrence.

Pull out Platter

This full-width side-out shelf tucked between the crispers and the lowest shelf is perfect for leftover family-sized casserole dishes, pizza boxes, and large party platters.

Delicates Pantry Drawers

To store things like meat, deli items, and drinks to keep in their ideal cooling environment.

Water Dispenser with Measured Fill

The Measured Fill feature allows you to dispense a desired amount of filtered water in handy increments like 0.2 liter, 0.5 liter and 1.0 liter.

Panoramic LED lighting

Multiple strips of LED lights inside the refrigerator compartment, freezer compartment, and interior drawers minimize shadows and evenly distribute light throughout the refrigerator.

Convertible Zone

Switch from freezer to fridge in one touch by selecting among the 6+ preset temperatures and create the space you want according to your evolving needs.

Active Oxygen

Hygiene, with innovative device releasing ozone to reduce odours and prevent the proliferation of bacteria inside the cabinet, improving the air quality for a better environment.

INSTALLATION INSTRUCTIONS

Getting Started INSTALLATION CHECKLIST

✓ Electrical Power

⚠ WARNING



Electrical Shock Hazard

Plug into a grounded 3 prong outlet.

Do not remove ground prong.

Do not use an adapter.

Do not use an extension cord.

Failure to follow these instructions can result in death, fire, or electrical shock.

- Plug refrigerator into a earthed socket.

✓ Doors

- If doors need to be removed during installation, see the “Remove and Replace Refrigerator Doors” and “Remove and Replace Freezer Door Fronts” sections.
- Doors seal completely.
- Refrigerator is level. Adjust leveling feet so they are snug against the floor.
- Doors are even across the top. (Use door alignment feature if necessary).

✓ Final Checks

- Remove all shipping material.
- Set temperature controls to the recommended setting.
- Save instructions and other literature.
- In order to receive a more complete assistance, please register your product on www.hotpoint.eu.

Water Filter Installation

- Locate the water filter compartment in the lower left-hand side of the refrigerator compartment. Push on the right side of the filter door to open.
- Align the arrow on the water filter cap with the cutout notch in the filter housing and insert filter.
- Once the filter is inserted, turn the filter clockwise 90° (1/4 turn) until it locks into the housing.
- Push water filter door closed to latch.
- Flush 3 gallons (11.4 L) of water through the water system to clear air from the water line and to keep the dispenser from dripping and/or avoiding decreased dispenser flow.
- Reset the filter counter via user interface. See the procedure to reset the filter in the User Controls section.

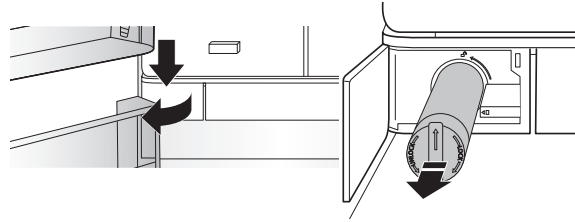

NOTE: If the filter is not installed correctly, water may dispense at a lower flow rate and there will be slower ice production. Improper filter installation may also cause the water filter housing to leak.

Unpack the Refrigerator

⚠ WARNING

Excessive Weight Hazard

Use two or more people to move and install refrigerator.

Failure to do so can result in back or other injury.

Refrigerator Delivery

A minimum door opening of 838 mm (33") is required. If door opening is 914 mm (36") or less, then removal of doors, drawer and hinges is required.

Cart the refrigerator from the side for all door openings.

When Moving Your Refrigerator:

Your refrigerator is heavy. When moving the refrigerator for cleaning or service, be sure to cover the floor with cardboard or hardboard to avoid floor damage. Always pull the refrigerator straight out when moving it. Do not wiggle or “walk” the refrigerator when trying to move it, as floor damage could occur.

Remove the Packaging

- Remove tape and glue residues from surfaces before turning on the refrigerator. Rub a small amount of liquid dish detergent over the adhesive with your fingers. Wipe with warm water and dry.
- Do not use sharp instruments, rubbing alcohol, flammable fluids, or abrasive cleaners to remove tape or glue. These products can damage the surface of your refrigerator.
- Dispose of/recycle all packaging materials.

Clean Before Using

After you remove all of the packaging materials, clean inside of your refrigerator before using it. See cleaning instructions in the “Refrigerator Care” section.

Important information to know about glass shelves and covers:

Do not clean glass shelves or covers with warm water when they are cold. Shelves and covers may break if exposed to sudden temperature changes or impact, such as bumping. Tempered glass is designed to shatter into many small, pebble-size pieces. This is normal. Glass shelves and covers are heavy. Use both hands when removing them to avoid dropping.

Location Requirements

⚠ WARNING



Explosion Hazard

Keep flammable materials and vapors, such as gasoline, away from refrigerator.

Failure to do so can result in death, explosion, or fire.

To ensure proper ventilation for your refrigerator, allow for a 1.25 cm space on each side and at the top. Allow for a 5 cm space behind the refrigerator. If your refrigerator has an ice maker, allow extra space at the back for the water line connections. When installing your refrigerator next to a fixed wall, leave a 9.5 cm minimum space between the refrigerator and wall to allow the door to swing open.

NOTE: This refrigerator is intended for use in a location where the temperature ranges from a minimum of 10°C to a maximum of 43°C. The preferred room temperature range for optimum performance, which reduces electricity usage and provides superior cooling, is between 15°C and 32°C. It is recommended that you do not install the refrigerator near a heat source, such as an oven or radiator.

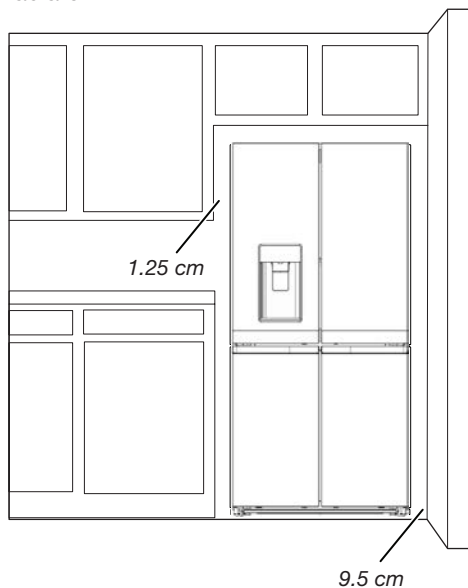

Electrical Requirements

⚠ WARNING



Electrical Shock Hazard

Plug into a grounded 3 prong outlet.

Do not remove ground prong.

Do not use an adapter.

Do not use an extension cord.

Failure to follow these instructions can result in death, fire, or electrical shock.

IMPORTANT: Installation and electrical connection must be carried out by a qualified technician according to the manufacturer's instructions and in compliance with the local safety regulations.

- The refrigerator is designed to operate on a separate 220-240 V, 10 A, 50-60 Hz circuit.
- Make sure the voltage specified on the rating plate corresponds to that of your home.
- It must be possible to disconnect the appliance from the power supply by unplugging it or by means of a main two pole switch installed upstream of the socket.
- If the supply cord is damaged, it must be replaced by the manufacturer, its service agent or similarly qualified persons in order to avoid a hazard.

Before you move your refrigerator into its final location, it is important to make sure you have the proper electrical connection:

Recommended Earthing Method

220-240 V 50 Hz, 220 V 60 Hz, or 230/240 V 50 Hz AC only 10 A fused and earthed electrical supply is required.

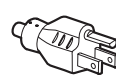

Type B

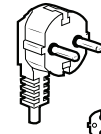

Type E and F

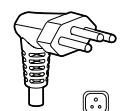

Type N

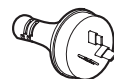

Type I

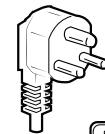

Type M



Type G

For Australia and New Zealand:

Your new appliance has been especially manufactured to meet all Australian Standards and Conditions.

Some notations in the installation instructions may refer to electrical requirements in other countries, so we draw your particular attention to these specific notes.

Your appliance needs to be plugged into a 230/240 V 50 Hz AC only 10 A earthed socket.

Electrical Requirements (Great Britain and Ireland only)

IMPORTANT: This refrigerator must be earthed.

Fuse Replacement

If the main lead of this refrigerator is fitted with a BS1363A, 13 A fused plug, to replace a fuse in this type plug use an A.S.T.A. approved fuse to BS 1362 type and proceed as follows:

1. Remove the fuse cover (A) and fuse (B).
2. Fit replacement 13 A fuse into the fuse cover.
3. Reinsert both the fuse and its cover into the plug.

IMPORTANT: The fuse cover must be refitted when changing a fuse. If fuse cover is lost, the plug must not be used until a correct replacement cover is fitted. A correct replacement is identified by the colour insert or colour "word" embossed on the base of the plug. Replacement fuse covers are available at your local electrical shop.

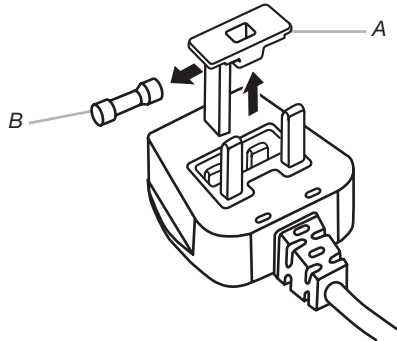

A. Fuse cover
B. Fuse

For the Republic of Ireland (only):

The information given in respect of Great Britain will frequently apply, but a third type of plug and socket is also used, the 2-pin, side earth type.

Socket/Plug (valid for both countries):

If the fitted plug is not suitable for your socket, please contact After-sales Service for further instruction. Please do not attempt to change the plug yourself. This procedure needs to be carried out by a qualified technician in compliance with the manufacturer's instructions and current standard safety regulations.

Temperature

This refrigerator is designed for operation in places where the temperature comes within the following ranges, according to climatic class shown on the rating plate. The refrigerator may not work properly if it is left for a long time at a temperature outside the specified range.

NOTE: It is recommended that you do not install the refrigerator near a heat source, such as an oven or radiator.

Climatic Class	Amb. T. (°C)	Amb. T. (°F)
SN	From 10 to 32	From 50 to 90
N	From 16 to 32	From 61 to 90
ST	From 16 to 38	From 61 to 100
T	From 16 to 43	From 61 to 110

Remove and Replace Refrigerator Doors

NOTE: Measure the width of your door opening to see whether or not you need to remove refrigerator doors to move refrigerator into your home. If door removal is necessary, see the following instructions.

IMPORTANT: If refrigerator was previously installed and you are moving it out of the home, turn refrigerator control off before you begin removing the doors. Unplug refrigerator or disconnect power. Remove food and adjustable door or utility bins from doors.

Gather required tools and read all instructions before removing doors.

TOOLS NEEDED: 6 mm socket wrench, 5 mm socket wrench and #2 Phillips screwdriver.



⚠ WARNING

Electrical Shock Hazard

Disconnect power before removing doors.

Failure to do so can result in death or electrical shock.

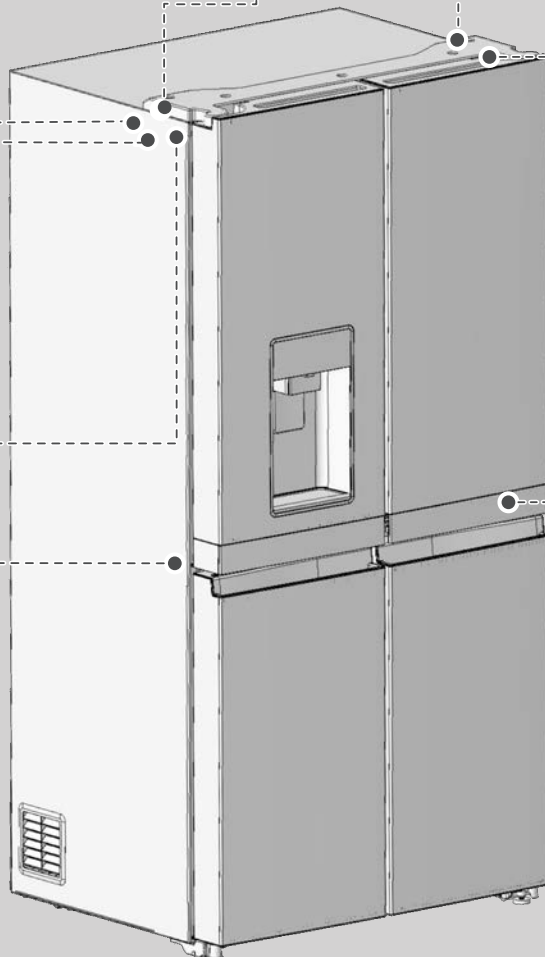
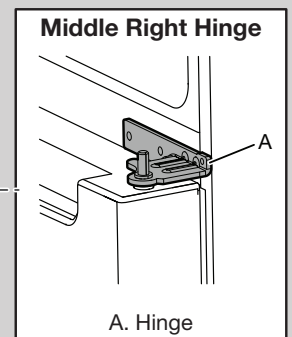
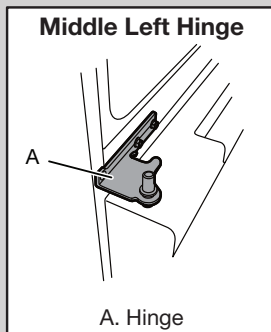
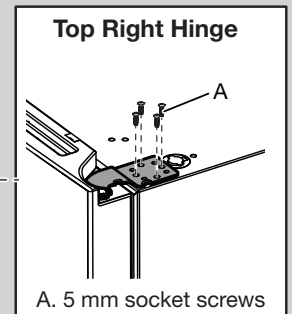
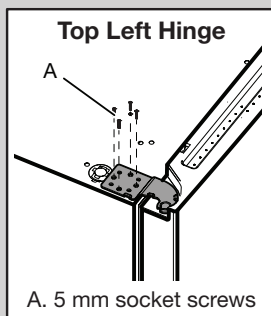
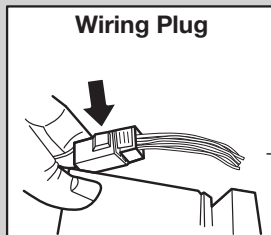
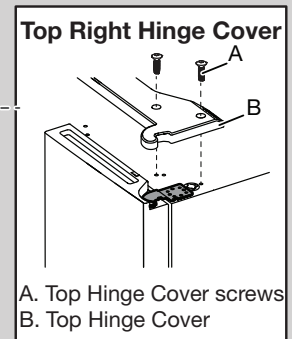
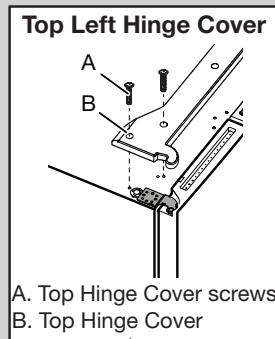
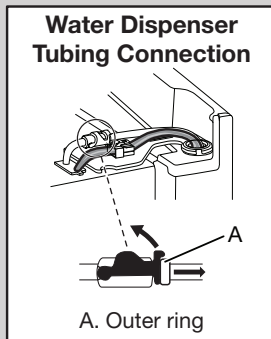

⚠ WARNING

Excessive Weight Hazard

Use two or more people to lift the refrigerator door.
Failure to do so can result in back or other injury.

Remove Refrigerator Doors

⚠ WARNING



Electrical Shock Hazard

Disconnect power before removing doors.
Failure to do so can result in death or electrical shock.

Remove Right-Hand Door

1. Unplug refrigerator or disconnect power.
2. Keep refrigerator doors closed until you are ready to lift them free from the cabinet.

NOTE: Provide additional support for refrigerator door while the hinges are being removed. Do not depend on the door gasket magnets to hold the door in place while you are working.

3. Using a Phillips screwdriver, remove cover from top hinge.
4. Using 5 mm socket wrench, remove four screws from top hinge and set aside.

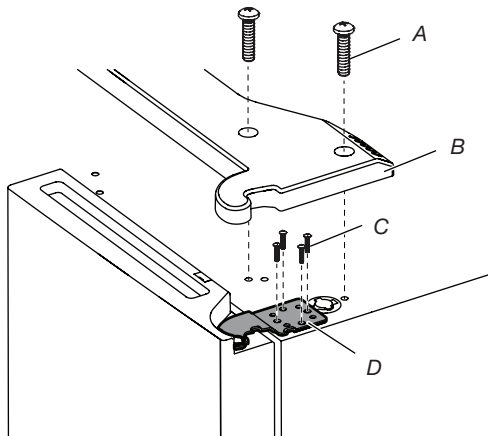

A. Top hinge cover screw
B. Top hinge cover
C. 5 mm socket screws
D. Top hinge

5. Lift refrigerator door from the middle hinge pin. The top hinge will come away with the door.

Remove Left-Hand Door

IMPORTANT: The wiring for UI run through left-hand door hinge, so they must be disconnected before removing the door.

1. Using a Phillips screwdriver, remove cover from top hinge.

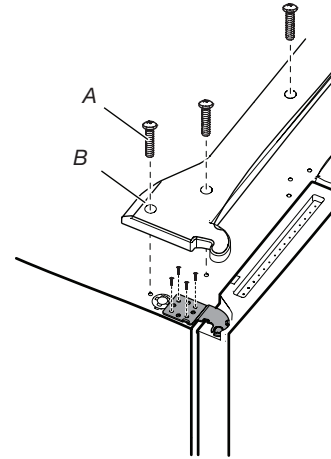

A. Top hinge cover screw
B. Top hinge cover

2. Disconnect two wiring plugs located on top of the door hinge.
 - Grasp each side of wiring plugs. With your left thumb, press down to release the catch and pull the sections of the plugs apart.

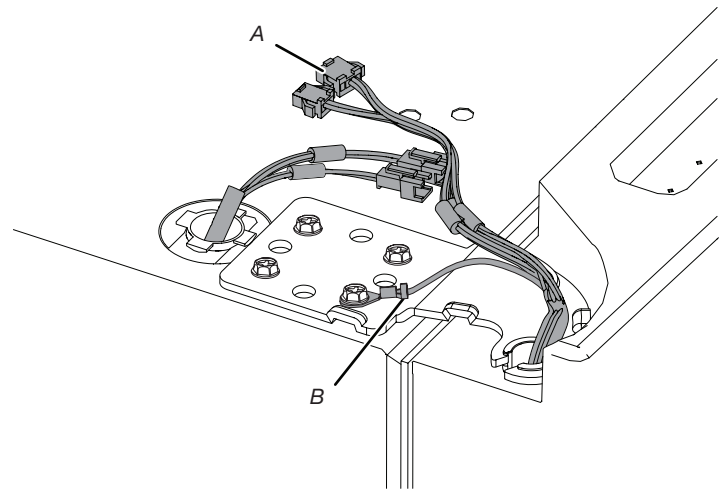

A. Wiring Plug
B. Ground (earth) connector

3. Disconnect the water dispenser tubing located on top of the door hinge. Firmly pull up on the clasp. Then, pull the tubing out of the fitting.

NOTE: The water dispenser tubing remains attached to the left-hand refrigerator door.

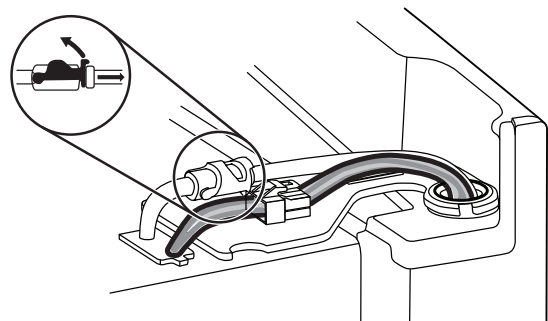

- Using 5 mm socket wrench, remove four internal screws from top hinge and set aside.

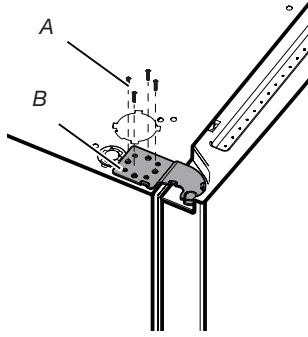

A. 5 mm socket screws
B. Top Hinge

NOTE: Provide additional support for refrigerator door while hinges are being removed. Do not depend on the door gasket magnets to hold the door in place while you are working.

- Lift refrigerator door from bottom hinge pin. The top hinge will come away with door.

NOTE: It may not be necessary to remove bottom hinges and brake feet assemblies to move the refrigerator through a doorway.

- Only if necessary, use 6 mm socket wrench and #2 Phillips screwdriver to remove middle hinge.

Replace Right-Hand Refrigerator Door

- Set right-hand door onto middle hinge pin.
- Insert top hinge pin into open hole in top of refrigerator door.
- Using four 5 mm socket screws, fasten hinge to cabinet. Do not tighten screws completely.

Replace Left-Hand Refrigerator Door

- Set left-hand door onto middle hinge pin.
- Using four 5 mm socket screws, fasten hinge to cabinet. Do not tighten screws completely.
- Reconnect electrical wiring.
 - Push together two sections of wiring plug.
 - Reconnect earth wire to hinge screw.

Final Steps

- Completely tighten eight 5 mm socket screws.
- Replace top hinge covers.

Remove and Replace Freezer/Flexi Freeze Door

- Keep freezer doors closed until you are ready to lift them free from cabinet.

NOTE: Provide additional support for freezer door while hinges are being removed. Do not depend on door gasket magnets to hold door in place while you are working.

- Using a #2 Phillips screwdriver and 6 mm socket wrench to remove middle hinge from cabinet.

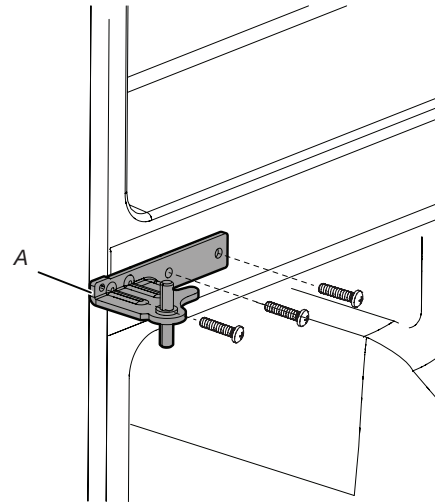

A. Middle hinge

- Lift freezer door from the bottom hinge pin.

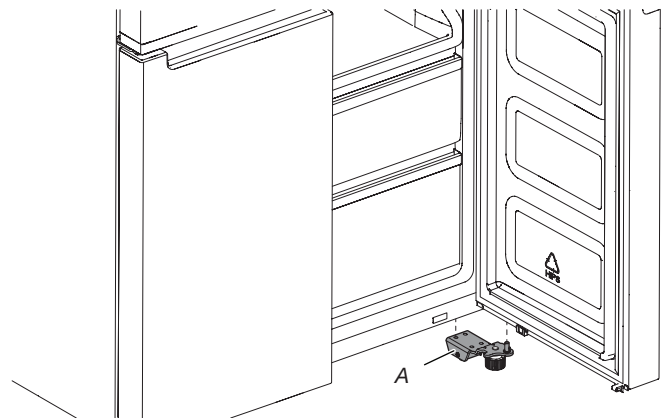

A. Bottom hinge

Final Steps

⚠ WARNING



Electrical Shock Hazard

Plug into a grounded 3 prong outlet.

Do not remove ground prong.

Do not use an adapter.

Do not use an extension cord.

Failure to follow these instructions can result in death, fire, or electrical shock.

1. Plug into an grounded (earthed) socket.
2. Return all removable parts and food to the drawers.

Refrigerator Levelling

1. Move refrigerator to its final location.
2. Using hand, rotate the brake feet. Turn them counterclockwise until the rollers are off the floor and both brake feet are snug against the floor. This keeps refrigerator from rolling forward when opening the doors.

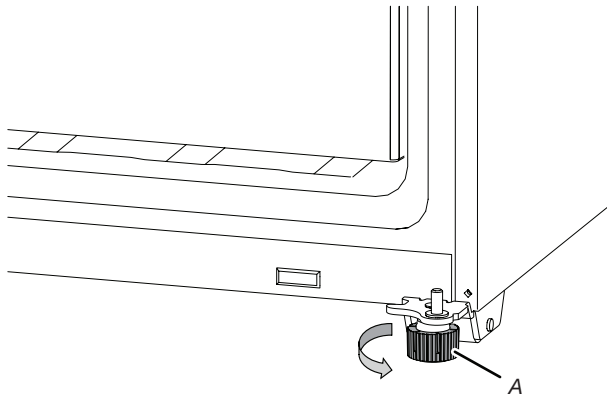

A. Brake feet

IMPORTANT: If you need to make further adjustments involving brake feet, you must turn both brake feet same amount to keep the refrigerator level.

3. Use a level to make sure refrigerator is level from side to side and front to back.

Water Supply Requirements

A cold water supply with water pressure between 20 psi and 145 psi (138 kPa and 1000 kPa) is required to operate the water dispenser and ice maker. If you have questions about your water pressure, call a licensed, qualified plumber.

NOTE: If the water pressure is less than what is required, the flow of water from the water dispenser could decrease or ice cubes could be hollow or irregular shaped.

Reverse Osmosis Water Supply

IMPORTANT: The pressure of the water supply coming out of a reverse osmosis system and supplying the water inlet valve of the refrigerator needs to be between 20 psi and 145 psi (138 kPa and 1000 kPa).

If a reverse osmosis water filtration system is connected to your home cold water supply, the water pressure to the reverse osmosis system needs to be a minimum of 40 to 60 psi (276 to 414 kPa).

- Check to see whether the sediment filter in the reverse osmosis system is blocked. Replace the filter if necessary.
- Allow the storage tank on the reverse osmosis system to refill after heavy use. The tank capacity could be too small to keep up with the requirements of the refrigerator.
NOTE: Faucet-mounted reverse osmosis systems are not recommended.
- If your refrigerator has a water filter, it may further reduce the water pressure when used in conjunction with a reverse osmosis system. Remove the water filter. See the “Water Filtration System” section.

If you have questions about your water pressure, call a licensed, qualified plumber.

Connect the Water Supply

Read all directions before you begin.

IMPORTANT:

- Connect to potable water supply only.

Do not use with water that is microbiologically unsafe or of unknown quality without adequate disinfection before or after the system. Systems certified for cyst reduction may be used on disinfected waters that may contain filterable cysts.

- Plumbing must be installed in accordance with the International Plumbing Code and any local codes and ordinances.
- Copper and PEX tubing connections from the household water line to the refrigerator are acceptable and will help avoid off-taste or odor in your ice or water. Check for leaks. If PEX tubing is used instead of copper, we recommend the following: 7 ft (2.14 m) jacketed PEX, 5 ft (1.52 m) PEX, or 25 ft (7.62 m) PEX.
- Install tubing only in areas where temperatures will remain above freezing.

Tools Needed:

Gather the required tools and parts before starting installation.

- Flat-blade screwdriver
- 7/16" and 1/2" open-end wrenches or 2 adjustable wrenches
- 1/4" nut driver

NOTE: Do not use a piercing-type or 3/16" (4.76 mm) saddle valve, which reduces water flow and clogs easier.

Connect to Water Line

IMPORTANT: If you have turned the refrigerator on before the water was connected, turn off the ice maker.

1. Unplug refrigerator or disconnect power.
2. Turn off main water supply. Turn on nearest faucet long enough to reduce water pressure in the water line.
3. Use a 3/4-14" shut-off valve or equivalent. The refrigerator is provided with a household supply line with the installation kit that connects to the shut-off valve and to the refrigerator.

NOTE: Appliance is equipped with a water installation kit. To assure proper connection to your water supply, use proper sealing material in the connection. Check if connection is sealed properly after some hours of operation.

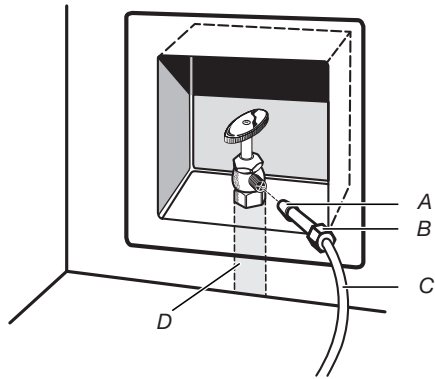

A. Sleeve C. Copper tubing (to refrigerator)
B. Nut D. Household supply line

4. Now you are ready to connect the copper tubing to the shut-off valve. Use 1/4" (6.35 mm) O.D. (outside diameter) soft copper tubing to connect the shut-off valve and the refrigerator.
 - Ensure that you have the proper length needed for the job. Be sure both ends of the copper tubing are cut square.
 - Slip compression sleeve and compression nut onto copper tubing as shown. Insert end of tubing into outlet end squarely as far as it will go. Screw compression nut onto outlet end with adjustable wrench. Do not overtighten.

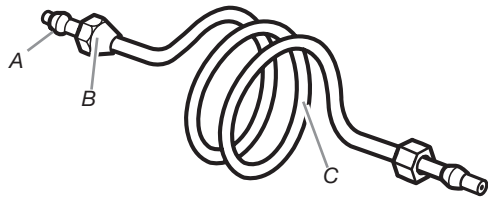

A. Compression sleeve C. Copper tubing
B. Compression nut

5. Place the free end of the tubing into a container or sink and turn on main water supply to flush out tubing until water is clear. Turn off shut-off valve on the water pipe.

NOTE: Always drain the water line before making the final connection to the inlet of the water valve to avoid possible water valve malfunction.
6. Bend the copper tubing to meet the water line inlet, located on the back of the refrigerator cabinet as shown. Leave a coil of copper tubing to allow the refrigerator to be pulled out of the cabinet or away from the wall for service.

Connect to Refrigerator

Follow the connection instructions specific to your model.

1. Remove plastic cap from water valve inlet port. Attach the copper tubing to the valve inlet using a compression nut and sleeve as shown. Tighten the compression nut. Do not overtighten. Confirm copper tubing is secure by pulling on copper tubing.
2. Create a service loop with the copper tubing. Avoid kinks when coiling the copper tubing. Secure copper tubing to refrigerator cabinet with a "P" clamp.

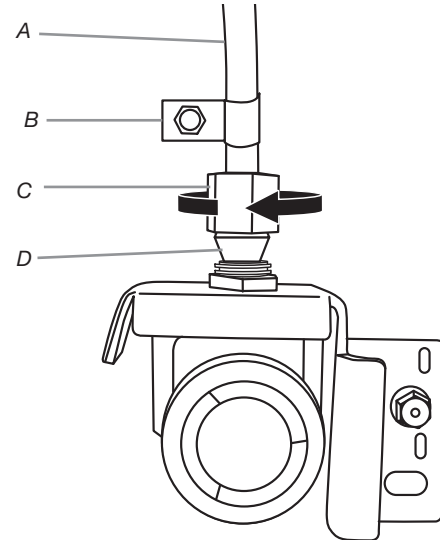

A. Copper tubing C. Compression nut
B. "P" clamp D. Compression sleeve

3. Turn on water supply to refrigerator and check for leaks. Correct any leaks.
4. If ice is desired, turn on the ice maker.

Note: Allow 24 hours to produce the first batch of ice. Discard the first three batches of ice produced. Allow three days to completely fill the ice storage bin.

FILTERS AND ACCESSORIES

Water Filtration System

Do not use with water that is microbiologically unsafe or of unknown quality without adequate disinfection before or after the system. Systems certified for cyst reduction may be used on disinfected waters that may contain filterable cysts.

Replace and Install the Water Filter

The water filter should be replaced every 6 months based on a flow rate of 0.50 gpm-0.60 gpm (1.89 lpm-2.27 lpm) that filters 200 gallons (757 L) of water.

To order a replacement filter, contact us. See the “Accessories” section in the Use and Care Guide for information on ordering.

1. Push the water filter door to open, located bottom left of refrigerator compartment.

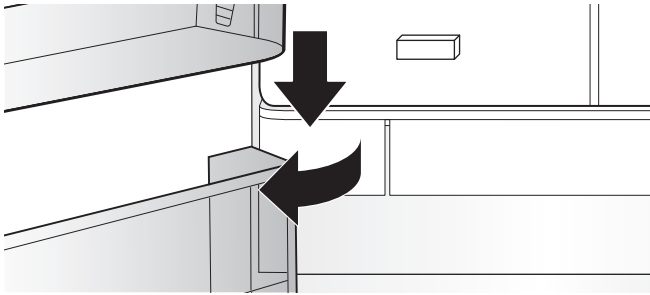

2. Twist the water filter and turn 90° counterclockwise to unlock.

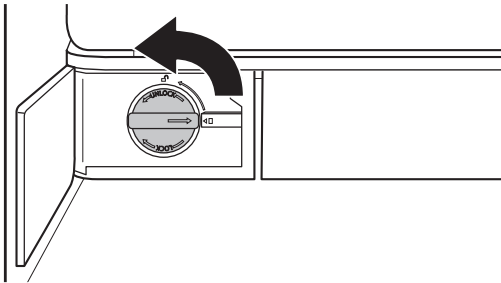

3. Pull the filter out of the housing.

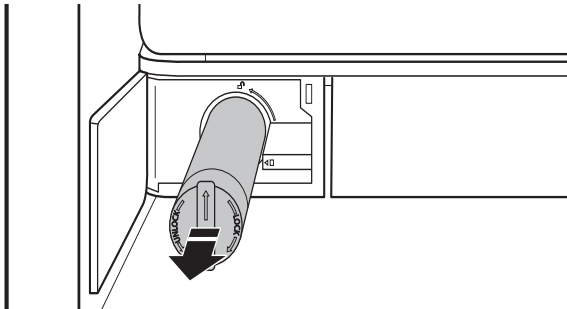

Remove the water filter cap from the water filter being replaced.

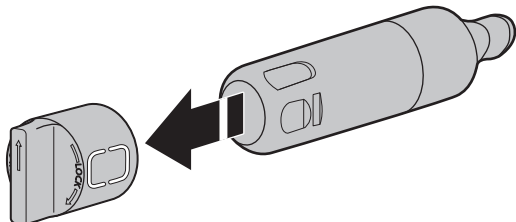

4. Install the water filter cap onto the new filter. Be sure to align the arrows so the grooves in filter align with ribs in filter cap.

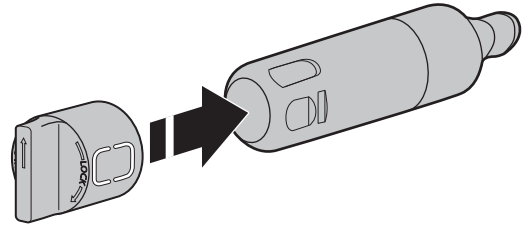

5. Insert the filter into the housing.

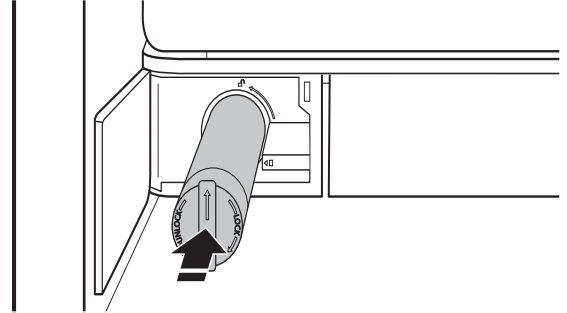

6. Twist the water filter and turn 90° clockwise until it locks into place and the arrows are aligned.

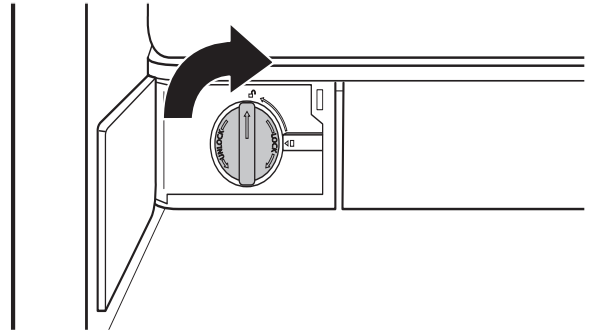

7. Push the water filter door closed.

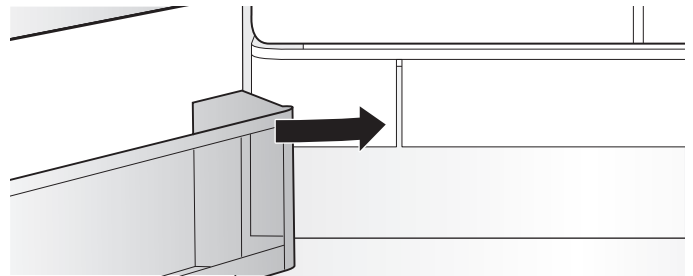

8. Reset the filter counter via user interface. See the procedure to reset the filter in the User Control section.

The Water Filter Status Lights

The Water Filter status lights will help you know when to change your water filter.

- **ORDER FILTER** (yellow) - It is almost time to change the water filter. "Order Filter" display is ON all of the time but OFF in Showroom mode.
- **REPLACE FILTER** (red) - Replace the water filter. While you are dispensing water, "Replace Filter" will blink 7 times and an alert tone will sound 3 times.
NOTE: "REPLACE FILTER" will remain illuminated if the filter is not reset on the user interface (UI).
- **RESET FILTER** - Touch "Filter Reset" button for 3 seconds to reset water filter. The display will do a 3-second countdown, then flash the icon and play a tone.

Replace and Install the Active Oxygen

It is recommended to replace the Active Oxygen every 3 years as the ozone generate degrades over time, reducing its impact on food preservation. At the beginning of life, it generates an average of 0.06 ppm.

To order and replace the Active Oxygen, please contact us. See the "Accessories" section for information on ordering.

Accessories

To order accessories, contact the dealer from whom you purchased your refrigerator.

Assistance or Service

Before calling for assistance or service, please check the "Troubleshooting" section. It may save you the cost of a service call. If you still need help, follow the instructions below.

If you need replacement parts

To locate factory-specified replacement parts in your area, contact the dealer from whom you purchased your refrigerator.

Warranty

Contact the dealer from whom you purchased refrigerator for warranty information.

Keep this book and your sales slip together for future reference. You must provide proof of purchase or installation date for in-warranty service.

Write down the following information about your appliance to help you obtain assistance or service if you ever need it. You will need to know your complete model number and serial number. You can find this information on the model and serial number label, located on the inside wall of the fresh food compartment.

Dealer name _____

Serial number _____

Address _____

Phone number _____

Model number _____

Purchase date _____

Refer to www.hotpoint.eu to contact.

USING THE CONTROLS

The touch-activated controls are located on the left hand refrigerator door. The control panel includes information about various buttons and indicators. Refrigerator and freezer temperature indicator shows last temperature set point.

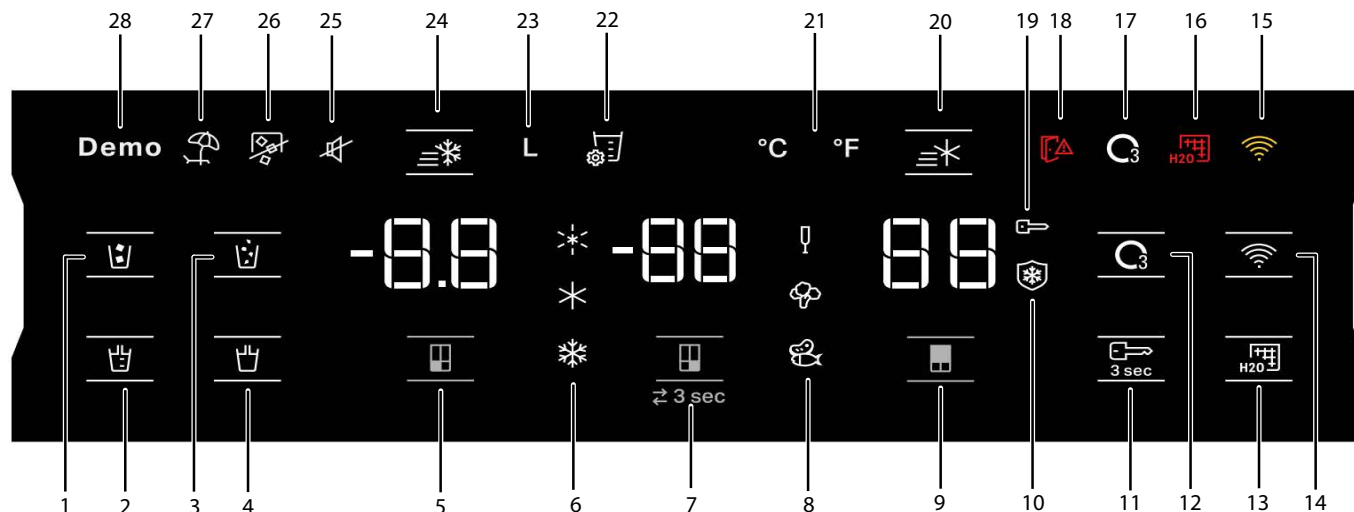

1. Cubed Ice BUTTON & INDICATOR
2. Measured Fill BUTTON & INDICATOR
3. Crushed Ice BUTTON & INDICATOR
4. Dispense Water BUTTON & INDICATOR
5. Freezer Compartment BUTTON & INDICATOR
6. Freezer Mild Freeze Fast Chill INDICATORS
7. Convertible Zone BUTTON & INDICATOR
8. Wine, Veggies, Meat & Fish INDICATORS
9. Refrigerator Compartment BUTTON & INDICATOR
10. Freeze Shield (No Freezer Burn) INDICATOR
11. Lock and Celsius/Fahrenheit BUTTON
12. Active Oxygen Indicator BUTTON & INDICATOR
13. Water Filter Reset BUTTON
14. Wi-Fi BUTTON & INDICATOR
15. Wi-Fi Error INDICATOR
16. Replace Water Filter INDICATOR
17. Replace Active Oxygen INDICATOR
18. Door Open INDICATOR
19. Lock INDICATOR
20. Fast Cool BUTTON & INDICATOR
21. Celsius/Fahrenheit INDICATOR
22. Calibrate Fill INDICATOR
23. Liters INDICATOR
24. Fast Freeze BUTTON & INDICATOR
25. Sound Off INDICATOR
26. Ice maker Off INDICATOR
27. Holiday Mode INDICATOR
28. Demo Mode INDICATOR

The Control Panel will automatically turn off after one minute of inactivity. To turn on the control panel, press any key.

-88 Viewing and Adjusting Temperature Set Points

Adjusting Fresh Food and Freezer Compartment Temperature:

For your convenience, your refrigerator and freezer controls are preset at the factory.

When you first install your refrigerator, make sure that the controls are still set to the recommended set points. The factory recommended set points are 3°C for the refrigerator and -18°C for the freezer.

Pressing Refrigerator or Freezer Temperature button will toggle through temperature set points in Celsius (°C).

IMPORTANT:

- Wait 24 hours before you put food into refrigerator. If you add food before refrigerator has cooled completely, your food may spoil.

NOTE: Adjusting the set points to a colder-than recommended setting will not cool compartments any faster.

- If the temperature is too warm or too cold in the refrigerator or freezer, first check the air vents to be sure they are not blocked before adjusting the controls.
- The recommended settings should be correct for normal household use. The controls are set correctly when milk or juice is as cold as you like and when ice cream is firm.







NOTE: Areas such as a garage, basement or porch may have higher humidity or extreme temperatures. You may need to adjust the temperature away from the recommended settings to accommodate for these conditions.

- Wait at least 24 hours between adjustments. Recheck the temperatures before other adjustments are made.

NOTE: To toggle the temperature between degrees Celsius and Fahrenheit, touch and hold "Max Ice" and "Max cool" buttons for 3 seconds and the temperature display will change.

Convertible Zone Setting

Convertibility function allows you to toggle preset temperature for Convertible Compartment. While toggling, the selected temperature displays in the user interface. Press and hold the convertible zone temperature button for 3 seconds to change between refrigerator and freezer presets.



Symbol	Function	Temperature
	Traditional Freezer: Food already frozen and fresh food for maximum 12 month	-16°C to -22°C
	Mild Freezer: Food already frozen for maximum 1 month	-12°C
	Soft Freezer: Food already frozen for maximum 1 week	-7°C
	Wine	10°C
	Veggies	4°C
	Meat and Fish	0°C

When adjusting temperature set points, use the following chart as a guide:

CONDITION	TEMPERATURE ADJUSTMENT
Refrigerator too cold	Refrigerator setting 1° higher
Refrigerator too warm	Refrigerator setting 1° lower
Freezer too cold	Freezer setting 1° higher
Freezer too warm/ too little ice	Freezer setting 1° lower



Fast Cool

The Fast Cool feature assists with periods of high refrigerator use, full grocery loads, or temporarily warm room temperatures. When turning on the Fast cool, the refrigerator compartment temperature will cool down faster than normal settings.

- To turn on the Fast Cool feature, press and hold the Refrigerator Temperature button  for 3 seconds. When feature is activated, the Fast Cool icon will be illuminated. The Fast Cool feature will remain on for 2 hours unless manually turned off.
- To manually turn off the Fast Cool feature, press and hold the Refrigerator Temperature button  for 3 seconds. The Fast Cool icon will turn off when feature is not activated.
- Adjusting refrigerator temperature will automatically turn off the Fast Cool feature.

Fast Freeze

The amount of fresh food (in kg) that can be frozen in 24 hours is indicated on the appliance rating plate. When turning on the Fast Freeze, the freezer compartment temperature will cool down faster than normal settings.

- Press Freezer Temperature button  for 3 seconds (until the Fast Freeze Indicator lights up), 30 hours before placing fresh food in the freezer. After placing fresh food in the freezer, 30 hours on Fast Freeze function is generally sufficient; After 50 hrs the fast freeze function automatically deactivates.
- To manually turn off the Fast Freeze feature, press and hold the Freezer Temperature button  for 3 seconds. The Fast Freeze icon will turn off.
- Adjusting the freezer temperature will automatically turn off the Fast Freeze feature.

Freeze Shield Feature

This feature minimizes moisture migration from frozen food. This feature will sub-cool the freezer compartment prior to defrost in order to reduce temperature variation. This feature will be enabled for a maximum of 2 hours prior to defrost.

Holiday Mode

This mode is designed to avoid your appliance from wasting energy during times when it's not in regular use (when you are on holiday for example).

By selecting this function the temperature of fresh food compartment will automatically be set to 12°C. This feature is not applicable to the Freezer and variable temperature compartments.

- To use the Holiday mode, press mode button until Holiday mode indicator is lit on the display.
- To exit the Holiday mode, press the mode button until no mode icon is lit on the display.
- Adjusting the refrigerator temperature will automatically turn off the Holiday Mode feature.

IMPORTANT: If this mode is selected then all food and drinks must be removed from fresh food compartment.

Sound ON-OFF

Press and hold "Filter Reset" and "Active Oxygen" buttons for 3 seconds to toggle the sound ON-OFF. If you turn on the sound, the "Sound" icon will light up on the display.

Key Lock

- Press and hold the Lock button for 3 seconds to activate lock feature.
- To deactivate lock, press and hold the Lock button for 3 seconds.

The lock feature will ignore all interaction with control panel and dispenser pads until the user unlocks the control panel. This feature is meant to avoid unintentional changing of settings.

Demo Mode

This mode is used when refrigerator is on display in a retail shop or if you want to turn the cooling off and deactivate all other functions (except interior lighting).

- If you turn on Demo mode, the "Demo" icon will light up on the display.
- Exit Demo mode by pressing and holding the "Measured Fill" and "Water Filter Reset" button simultaneously for 3 seconds.

Active Oxygen

The refrigerator has a Ozone generator located in the center of the air tower. The Active Oxygen can be enabled or disabled.

- Once the Active Oxygen Button light is on, press the button to turn the Active Oxygen off. Toggle the button to enable/disable the Active Oxygen.

The Active Oxygen expires in 3 years of usage. Once the 3 years life is reached, the Active Oxygen icon will turn on. After changing the Active Oxygen, the alarm can be reset.

- Pressing the Active Oxygen reset button for 3 seconds will reset the counter and turn off the Active Oxygen Replace Indicator

Additional Features

Door Ajar Alarm

The Door Ajar Alarm feature sounds an alarm when the refrigerator door(s) or freezer drawer is open for 5 minutes and cooling is turned on. The alarm will repeat every 2 minutes. Close all doors and drawer to turn it off.

NOTE: To mute the audible alarm while keeping the doors open, such as while cleaning the inside of the refrigerator, touch any button on the control panel. The alarm sound will be temporarily turned off, but the Door Ajar icon will still be displayed on the dispenser control panel.

Water Filter Reset and Indicator

Displays the status of the water filter. To reset the filter, press Water filter reset button for 3 seconds. After countdown, the icon will blink 3 times and the filter reset operation is completed.

The Water Filter status lights on the internal controls will let you know when to change your water filter.

- **ORDER FILTER (Yellow):** Order a replacement water filter.
- **REPLACE FILTER (RED):** Replace the water filter. While you are dispensing water, "Replace Filter" icon will flash constantly from beginning to the end of dispensing. After 14 days without replacing the water filter, the "Replace Filter" icon will blink 7 times and an alert tone will sound 3 times at the end of dispensing. See the "Water Filtration System" section.

REFRIGERATOR CONNECTIVITY FEATURES (ON SOME MODELS)

Wi-Fi connectivity allows your Smart Refrigerator to connect to the Internet and interact with the Hotpoint® app from your smartphone or mobile device. This connection opens up several Smart options to you — options intended to save you valuable time and energy. Refer to the "Troubleshooting—Connected Models" section of this Use & Care Guide, check any connection instructions for your specific router.

NOTE: Requires Wi-Fi and account creation. App features and functionality subject to change. Subject to Terms of Service available on Hotpoint website.



SMART FEATURES

Smart Features help make your everyday a little more efficient by letting you remotely monitor, manage, and maintain your refrigerator.

Remote Temperature Control

What it does: Allows you to control your refrigerator remotely from your mobile device via the Hotpoint® app.

What it does for you: Lets you control temperatures in your refrigerator, freezer, and temperature-controlled pantry remotely — not just when you are standing in front of it.

Water Filter Status

What it does: Gives you a look at the life remaining for your water filter before replacement is needed. This allows you to reset the filter.

What it does for you: Helps you be more efficient in planning for ordering and replacing filters.

Auto Reorder App

What it does: Allows you to order replacement filters, consumables, and accessories via the Hotpoint® app for delivery directly to your home.

What it does for you: Simplifies ordering correct water and air filters—no trips to the store searching for the correct filters.

Door Ajar Alert

What it does: Sends you a notification when one of the doors of the refrigerator has been left open.

What it does for you: Alerts you to door-open status so you can close the door(s) or call home to ask someone else to close door(s) before over-temperature situation arises.

Fast Cool

What it does: Allows you to control your refrigerator remotely from your mobile device via the Hotpoint® app.

What it does for you: Lets you turn on/off Fast Cool options remotely to make temperatures colder in the refrigerator in anticipation of loading newly purchased grocery items. Lowers internal temperatures for 24 hours.

NOTE: REPLACE FILTER will remain illuminated if a filter reset is not done.

Lighting the Refrigerator

The refrigerator has an interior light that comes on any time door is opened.

NOTE: The light is LED which does not need to be replaced. If the LED does not illuminate when the door is opened, call service.

Fast Freeze

What it does: Allows you to control your freezer remotely from your mobile device via the Hotpoint® app.

What it does for you: Lets you turn on/off Fast Freeze remotely to increase ice production. Reduces the set temperature to the lowest possible setting for 24 hours to maximize ice production.

Freeze Shield® Mode Control

What it does: Allows you to receive status of your refrigerator remotely to your mobile device via the Hotpoint® app.

What it does for you: Informs you whether Freeze Shield® mode is active in your refrigerator to reduce freezer burn and help frozen items maintain their appearance and taste.

Holiday Mode

What it does: Allows the refrigerator to cool efficiently and save energy during holiday mode. Allows you to turn on and off remotely from your mobile device via the Hotpoint® app.

What it does for you: Lets you turn on/off Holiday mode options Remotely.

Ice Maker On/Off

What it does: Allows you to turn on and off the Ice maker in your refrigerator remotely on your mobile device via the Hotpoint® app.

What it does for you: Lets you turn on/off your Ice maker remotely.

Lock Mode

What it does: Allows you to lock and unlock the user interface on your refrigerator remotely on your mobile device via the Hotpoint® app.

What it does for you: Lets you lock and unlock the user interface remotely for easy cleaning and or to avoid unintentional dispensing by small children or pets.

GET STARTED

To connect your new refrigerator to internet, please download Hotpoint Home Net App, create an account and then follow the in App instructions on how to connect your appliance.

Check the Hotpoint® app frequently for additional information and features.

Requires Wi-Fi and account creation. App features and functionality subject to change. Subject to Terms of Service available on Hotpoint website and inside the App. Data rates may apply.

CONNECTIVITY SETUP (ON SOME MODELS)

IMPORTANT: Proper installation of your refrigerator prior to use is your responsibility. Be sure to read and follow the User Instructions that came with your refrigerator.

Automatic Set-Up Instructions – Wi-Fi Protected Setup (WPS)

You will need:

- A home wireless router capable of WPS. The router should be ON and have a live Internet connection.

NOTE: Router needs to be 2.4 GHz. Refrigerator shall not be able to connect to 5 GHz

- The Smart Appliance Identification Number (SAID) from your refrigerator. This is located on a sticker on the front side of the right-hand hinge cover of the refrigerator.

NOTE: If your home wireless router is not equipped with a WPS button, please check the user manual of your router to confirm if it is WPS capable. If not, alternate set-up instructions are available in the app.

Setup router

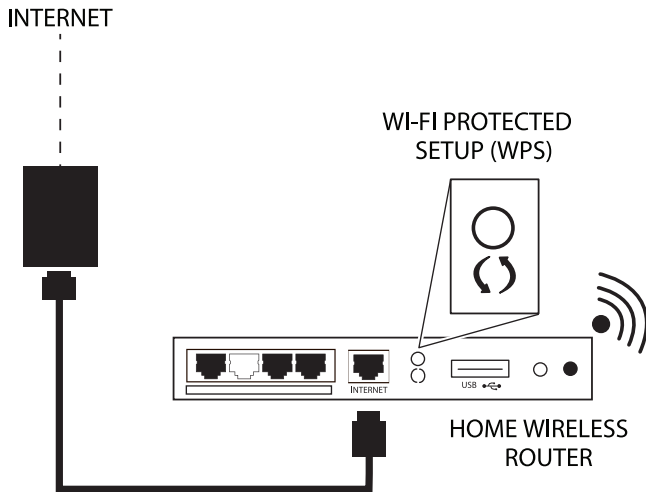

Press the WPS button on the router. An indicator light will begin blinking.

HELPFUL TIP: The WPS function on your router is active for 2 minutes. Complete the next step within that timeframe or you will need to reinitiate WPS.

Setup refrigerator (time-sensitive step)



Press and hold Connect button for 3 seconds on Home screen. The Wi-Fi status indicator (☺) on the refrigerator control panel will blink slowly while your refrigerator and router attempt to connect. If the connection is successful, the Wi-Fi status indicator will come on and remain lit.

If Your Refrigerator Doesn't Connect:

If your refrigerator and router fail to connect after 2 minutes, the Wi-Fi status indicator will blink rapidly for 5 seconds and then turn off. Refer to the "Troubleshooting—Connected Models" section of this Use & Care Guide, check any connection instructions for your specific router, and refer to alternate instructions in the mobile App.

NOTE: If this is your first Smart Appliance, you will need to download the Hotpoint® app and create an online user account.

If you already have the app and a user account, please skip ahead to Step 4 "Register your refrigerator in your user account."

To disconnect Wi-Fi, press and hold Connect button for more than 15 seconds, the (☹) icon will turn off, indicating that you have disabled the Wi-Fi radio.

To reconnect Wi-Fi, press and hold Connect button for 3 seconds on the Home screen.

The Wi-Fi status indicator (☺) on the refrigerator control panel will blink slowly while your refrigerator and router attempt to connect.

If the connection is successful, the Wi-Fi status indicator will come on and remain lit.

To disconnect your refrigerator from your router, press and hold CONNECT for more than 15 seconds. The (☹) icons will turn off, indicating that your refrigerator is completely disconnected from Wi-Fi and your router.

To re-connect your refrigerator to your router and reconnect Wi-Fi, press and hold CONNECT for 3 seconds on the Home screen.

The Wi-Fi status indicator (☺) on the refrigerator control panel will blink slowly while your refrigerator and router attempt to connect. If the connection is successful, the Wi-Fi status indicator will come on and remain lit.

Press the WPS button on the router. An indicator light will begin blinking.

HELPFUL TIP: The WPS function on your router is active for 2 minutes. Complete the next step within that time-frame or you will need to re-initiate WPS.

Download Hotpoint® app and set up user account

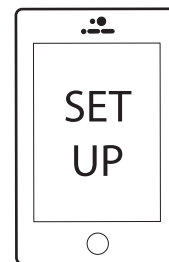

From your mobile device, smartphone or tablet, go to the App store and download and install Hotpoint Home Net App.

Once installed, tap the Hotpoint® app icon to open the app. You will be guided through the steps to set up a user account. The app will make sure to get the necessary personal and home information as well as information about your energy company.

Register your refrigerator in your user account

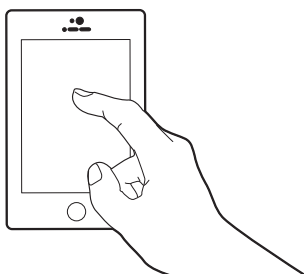

Registering your refrigerator in your account is a necessary step in order for you to take full advantage of the Smart features. When prompted by the app, enter the SAID (case sensitive), which can be found on a sticker on the front side of the right hand hinge cover of the refrigerator.

My Smart Appliance ID# is:

- The Wi-Fi status indicator on the refrigerator control panel will blink slowly while your refrigerator and router attempt to connect.
- Note that this blinking only applies to first-time registration after provisioning. No blinking behavior for automatic reconnection after a connection is established.
- Once you've connected your refrigerator to your home Wi-Fi network, it will remain linked even if the power goes out, you move the appliance, or if you put it in storage for a while.
- If you replace your wireless router (or get a different Smart refrigerator), you will need to repeat this connectivity set-up process.

Note: During product registration, mobile phone and appliance have to be connected to the same Wi-Fi network

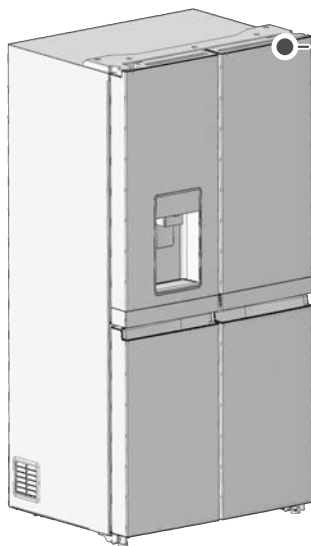

The Smart Appliance Identification Number (SAID) is located on a sticker on the front side of the right-hand hinge cover of the refrigerator.

Water and Ice Dispensers

IMPORTANT:

- Allow 3 hours for the refrigerator to cool down and chill water.
- Allow 24 hours to produce the first batch of ice. Discard the first 3 batches of ice produced.
- The dispensing system will not operate if the left-hand refrigerator door is open.

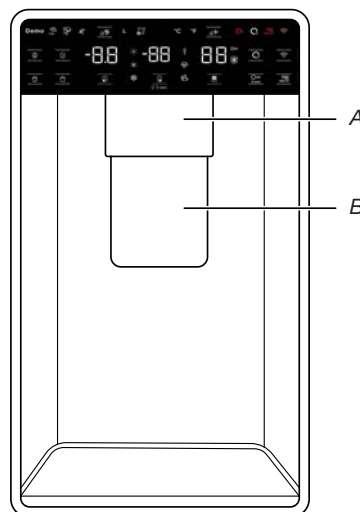

A. Water dispenser paddle
B. Ice dispenser paddle

Flush the Water System

Air in the water dispensing system can cause the water dispenser to drip. After connecting the refrigerator to a water source or replacing the water filter, flush the water system.

Flushing the water dispensing system forces air from the water line and filter and prepares the water filter for use. Additional flushing may be required in some households.

NOTE: As air is cleared from the system, water may spurt out of the dispenser.

1. Using a sturdy container, depress and hold the water dispenser paddle for 5 seconds.
2. Release the dispenser paddle for 5 seconds. Repeat steps 1 and 2 until water begins to flow.
3. Once water begins to flow, continue depressing and releasing the dispenser pad (5 seconds on, 5 seconds off) until a total of 3 gal. (12 L) has been dispensed.

Calibrate Measured Fill

Household water pressure may affect the accuracy of the Measured Fill feature. So, for optimum performance of your water dispenser, you must first calibrate Measured Fill.

IMPORTANT:

- Flush the water system before calibrating Measured Fill.
- For best results, calibration should be performed when water is not being used in the house.

- Place a sturdy measuring cup (1-cup [0.2 L] size) on the dispenser tray centered in front of the ice/water dispenser paddle.
NOTE: Depending on your model, a measuring cup may be provided.

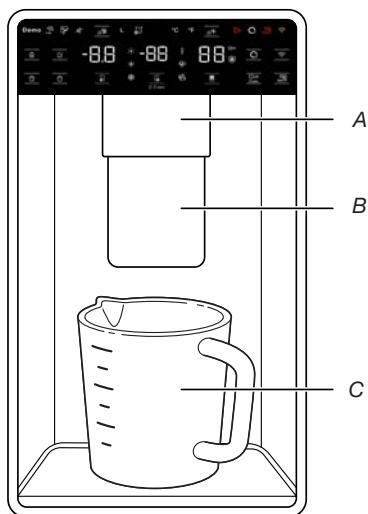

A. Water dispenser paddle
B. Ice dispenser paddle
C. Measuring cup (1 cup)

Ensure that you do not have any Measured Fill preset selected.

- Touch and hold the Measured Fill button for 3 seconds to enter into Calibration mode. The Calibration icon and Measured Fill icon will illuminate and remain lit while the Measured Fill feature is being calibrated.
NOTE: You may touch MEASURED FILL to exit at any time in Calibration mode. The Calibration and Measured Fill icons will disappear.
- Press and hold the water dispenser paddle, as needed, to dispense water to the 1-cup fill line in the measuring cup.
NOTE: If overflowing or spilling occurs, discard the water and restart the calibration process.
- When 1 cup of water has been correctly dispensed into the measuring cup, touch MEASURED FILL to confirm the calibration.
- When Measured Fill calibration has been confirmed, the Calibration icon will disappear and the display will return to the home screen.

Dispensing

Touch CUBED ICE or CRUSHED ICE for your ice selection.

NOTES:

- For crushed ice, cubes are crushed before being dispensed. This may cause a slight delay when dispensing crushed ice. Noise from the ice crusher is normal and pieces of ice may vary in size.
- When changing from crushed to cubed, a few ounces of crushed ice will be dispensed along with the first cubes.

Dispensing Water

IMPORTANT:

- Dispense at least 1 qt (1 L) of water every week to maintain a fresh supply.
- If the flow of water from the dispenser decreases, it could be caused by low water pressure.
 - With the water filter removed, dispense 1 cup (0.2 L) of water. If 1 cup (0.2 L) of water is dispensed in 8 seconds or less, the water pressure to the refrigerator meets the minimum requirement.

- If it takes longer than 8 seconds to dispense 1 cup (0.2 L) of water, the water pressure to the refrigerator is lower than recommended. See the “Water Supply Requirements” and “Troubleshooting” sections for suggestions.

To Dispense Water - Standard:

- Press a sturdy glass against the water dispenser paddle.
- Remove the glass to stop dispensing.

NOTE: The Dispense Water button does not enable standard dispensing. It only functions in Measured Fill mode.

To Dispense Water - Measured Fill:

Measured Fill allows you to dispense a specified amount of water with the touch of a few buttons.

- Put a sturdy glass under water spout. Touch MEASURED FILL to activate.
NOTE: The amount of water you select will be dispensed. Make sure the container can hold the entire volume. If ice is in the container, you may need to adjust your selection.
- Touch MEASURED FILL to turn on, then touch to select 8 oz (0.2 L), 16 oz (0.5 L), or 32 oz (1L). Touch the fourth time to exit Measured Fill display.
- Touch DISPENSE WATER (center button) or press paddle and the selected amount of water will be dispensed.

NOTES:

- The Measured Fill dispenser will automatically time out after 1 minute of inactivity.
- You can refill several glasses with the same measurement by continuing to touch DISPENSE WATER (center button) after each glass fill.

Measured Fill options are listed in the following chart:

Units			
Ounces	8	16	32
Cups	1	2	4
Liters	0.2	0.5	1

NOTE: Most coffee cups (commonly 4 to 6 oz [118 to 177 mL] per cup) are not the same size as a measuring cup (8 oz [0.2 L]). You may need to recalibrate Measured Fill to underfill or to avoid unintentionally overflowing coffee cups.

- Dispense water.

NOTE: While dispensing water, the flow of water will automatically stop once the desired volume has been dispensed.

- Press a sturdy glass against the dispenser paddle below the water spout.

OR

- Place the glass below the water spout and touch DISPENSE WATER for hands-free dispensing.

- To pause dispensing before the selected volume has been dispensed, touch DISPENSE WATER a second time or touch the water dispenser paddle. Touch DISPENSE WATER or paddle again to resume dispensing remaining amount.

NOTE: If you stop dispensing before the desired volume has been dispensed, the display will turn off after 1 minute. If you have not resumed by then, it will reset back to the original amount.

- To select a new volume or start dispensing the same volume again, you must first finish dispensing the selected volume or turn off the Measured Fill feature (either by waiting 1 minute, so it will automatically turn off, or by touching CUBED ICE or CRUSHED ICE to manually turn it off), and then select Measured Fill again.

REFRIGERATOR USE

Opening and Closing Doors

There are two fresh food compartment doors. The doors can be opened and closed either separately or together. There is a vertically hinged seal on left refrigerator door.

- When left-side door is opened, hinged seal automatically folds inward so that it is out of the way.
- When both doors are closed, the hinged seal automatically forms a seal between two doors.

NOTE: When closing the door, the hinged seal should be in correct position (be bent inside). Otherwise it will hit the right door or the fixing shaft.

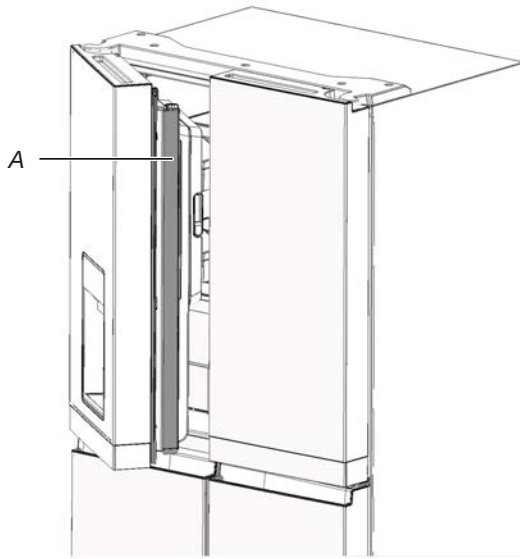

A. Hinged seal

The fresh food compartment door switch is located in top left and right hinge cover.

- For Freezer and Convertible Zone, door switch is located in the bottom mullion.
- The door switch uses magnet to sense door opening/closing.
- Ensure there are no magnet or electronic devices (Speaker, Coolvox® etc.) within 7.62 cm of the hinge cap.

NOTE: The light will not turn on if door opening is not detected.

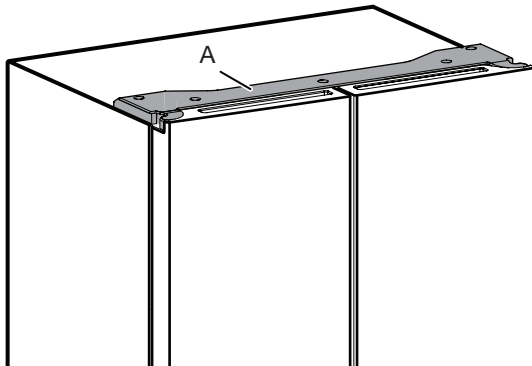

A. Hinge cover

Shelf Height Adjustment

Shelf height can be adjusted by changing its location from bottom support to upper support and vice versa.

- Open right side door and left side door till 130°.

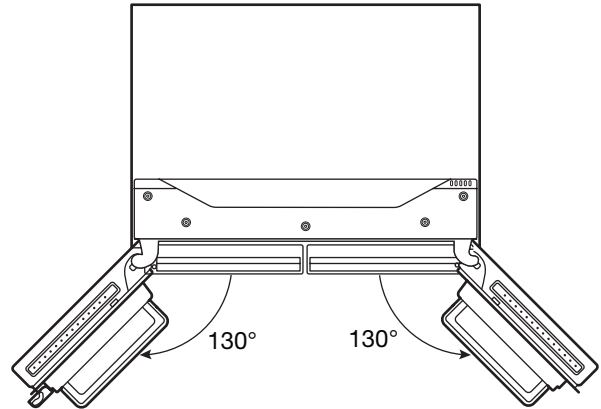

The Ice Dispenser

IMPORTANT:

- If the ice cubes are hollow or have an irregular shape, it could be because of low water pressure. See the "Water Supply Requirements" section.
- Ice travels from the ice storage bin through the dispenser chute to the dispenser. To turn off the ice maker, see the "Ice Maker and Storage Bin" section.
- The dispenser may continue to make noise and ice may continue to dispense for several seconds after releasing the dispenser button or paddle.

To Clean the Ice Dispenser Chute:

Humidity causes ice to naturally clump together. Ice particles can build up until the ice dispenser chute becomes blocked.

If ice is not dispensed regularly, it may be necessary to empty the ice storage bin and clean the ice delivery chute, the ice storage bin, and the area beneath the storage bin every 2 weeks.

- If necessary, remove the ice clogging the storage bin and delivery chute using a plastic utensil.
- Clean the ice delivery chute and the bottom of the ice storage bin using a warm, damp cloth, and then dry thoroughly.

To Dispense Ice - Paddle Dispensing

1. Select the desired type of ice by pressing CUBED ICE or CRUSHED ICE.

⚠ WARNING



Cut Hazard

Use a sturdy glass when dispensing ice.

Failure to do so can result in cuts.

2. Press a sturdy glass against the dispenser paddle. Hold the glass close to the dispenser opening, so ice does not fall outside of the glass.

IMPORTANT: You do not need to apply a lot of pressure to the paddle to activate the ice dispenser. Pressing hard will not make the ice dispense faster or in greater quantities.

- Remove the glass to stop dispensing.

NOTE: Ice may continue to dispense for several seconds after removing the glass from the dispenser paddle. The dispenser may continue to make noise for a few seconds after dispensing.

The Dispenser Drip Tray

The drip tray can be removed for cleaning. Start the following steps from the pulled in position.

- Lift up on the front edge of the tray and pull forward to remove.

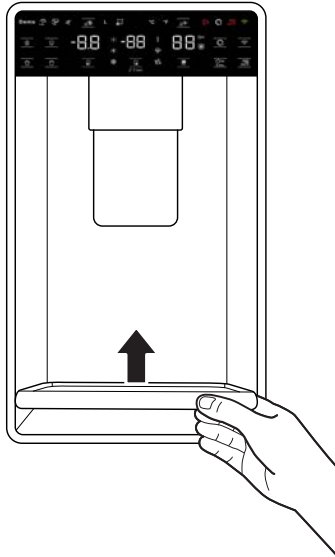

- Pull the tray out angled to the top front direction.

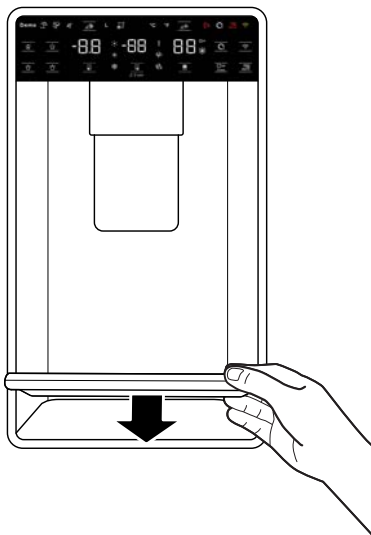

To install it back follow the two steps below.

- Position the tray horizontally on the rails with some space at the rear part.
- Push downward and pull towards you to engage to the rail.

The drip tray can be pulled out to accommodate larger containers for measured fill.

The Dispenser Light

- When you use the dispenser, the light will automatically turn on.
- The dispenser light also serves as an automatic night light. Once the ambient light in the room is reduced, the auto sensor will cause the dispenser light to illuminate.

Ice Maker and Storage Bin

IMPORTANT: To avoid low ice production and poor quality ice, flush the water system before turning on the ice maker. See the “Water Dispenser” section.

- Following installation, allow 24 hours to produce the first batch of ice. Discard the first 3 batches of ice produced. Allow 2 to 3 days to fill the ice storage bin.
- The quality of your ice will be only as good as the quality of the water supplied to your ice maker. Avoid connecting the ice maker to a softened water supply. Water softener chemicals (such as salt) can damage parts of the ice maker lead to poor quality ice. If a softened water supply cannot be avoided, make sure the water softener is operating properly and is well-maintained.
- If the ice in the storage bin clumps together, break up ice using a plastic utensil and discard. Do not use anything sharp to break up the ice. This can cause damage to the ice bin and the dispenser mechanism.
- Do not store anything in the ice storage bin.

Style 1 - Ice Maker in the Refrigerator

The ice maker is located on the left door behind the bins. Ice cubes are ejected into the ice storage bin located on the left-hand refrigerator door.

Remove and Replace the Ice Storage Bin

To open the Ice Maker box, pull the ice maker door lever until the door releases.

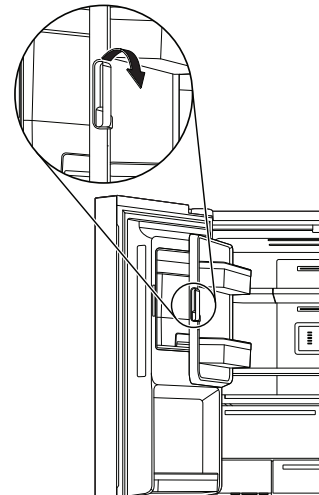

- Remove the ice storage bin by inserting your fingers into the hole at the base of the bin and pulling the latch to release the bin from the compartment. Lift the storage bin up and pull it straight out.
- Replace the storage bin inside the ice compartment and push down to make sure it is firmly in place.

Ice Production Rate

- Your ice maker should produce approximately 3.5 lbs (1.6 kg) of ice per day under normal operation.

Turn the Ice Maker On/Off

- To turn the ice maker on, press and hold “Crush” and “Cubed” buttons on the display. The “Ice maker off” indicator will blink 3 times and turn off.
- To manually turn the ice maker off, press and hold “Ice maker off” button on the display. The “Ice maker off” indicator will blink 3 times and remain lit on the display screen.

NOTES:

- Your ice maker has an automatic shutoff. The sensor will automatically stop ice production if the storage bin is full or the door is open. The control will remain in the On position.

SHELVES, BINS, AND DRAWERS

Shelves and Shelf Frames

The shelves in your refrigerator are adjustable to meet your individual storage needs.

Storing similar food items together in your refrigerator and adjusting the shelves to fit different heights of items will make finding the exact item you want easier. It will also reduce the amount of time the refrigerator door is open and save energy.

Shelf Height Adjustment

Shelf height can be adjusted by changing the adjustable shelf mounts between their vertical and horizontal positions.

1. Carefully lift the shelf off the shelf mounts and turn the flipper to the desired orientation.
2. Repeat for remaining shelf mounts.
3. Apply pressure to the top of the shelf to ensure the shelf is properly seated on the shelf mounts.

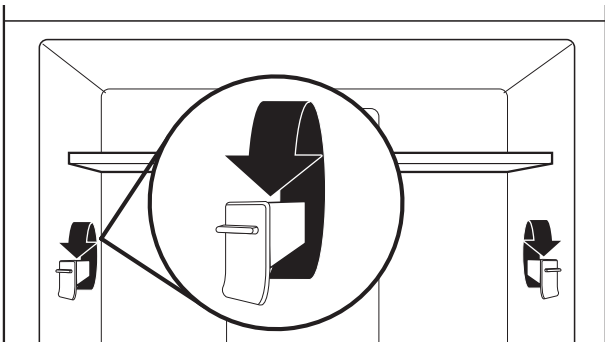

NOTES:

- You will need to remove middle shelf first before removing top shelf.
4. Remove the bottom shelf by lifting it up and out of the shelf supports. Then pull the shelf forward and tilt up to a vertical position. Turn the shelf at an angle and pull out of the refrigerator.
 5. Replace the bottom shelf by putting the shelf in the refrigerator at an angle with the shelf up. Lift the front of the shelf down and in until rear shelf drops into the shelf supports. Lower the front of the shelf and make sure that the shelf is in position.

Pull out platter Removal

To remove and replace pull-out platter:

NOTE: Refrigerator doors will need to be removed to remove Pull out platter. See the “Remove and Replace Refrigerator Doors” section for more information.

1. Pull the pull-out platter to the fully open position or when it stops.
2. Locate the pull-out platter retention clips on both sides. These are in the side under the pull-out platter.

3. Push the clip up from the bottom with your finger.
4. After both clips have been disengaged, carefully remove the pull-out platter toward the front of the refrigerator.

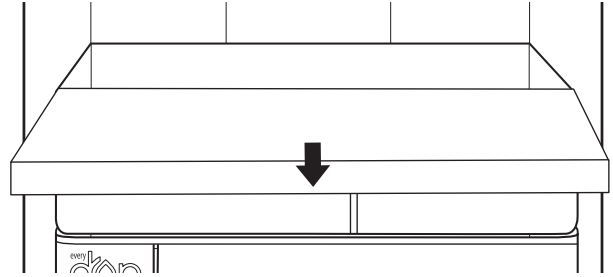

Crisper Drawers

To remove and replace the drawers:

1. Grasp the handle at the bottom of the drawer and slide the drawer straight out to the stop. Lift the drawer off the bottom guide.
2. Replace the drawer by placing it on the bottom drawer guide and pushing it past the drawer stop into position.

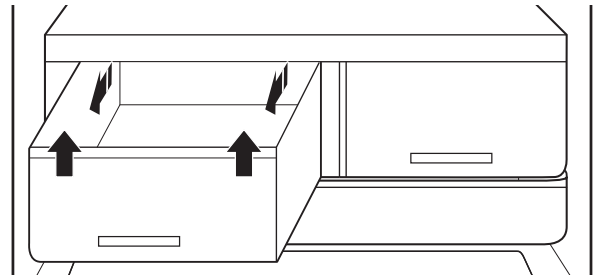

Refrigerator Door Bins

The bins on your refrigerator door are adjustable to meet your individual storage needs. The bins make it easy to customize door storage to hold gallon containers.

Door Bin Divider (on some models)

This divider fits in the door bin to divide the bin and elevate smaller items at the back of the bin.



Freezer Storage Compartments

Easy Access Tray

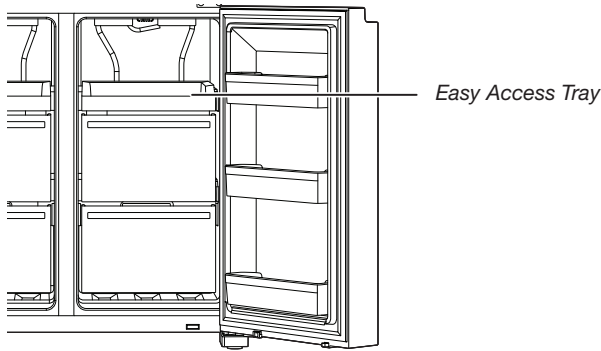

Easy Access tray is useful to easily access frequently used products, freeze or simply store leftovers or small items.

Freezer Drawers

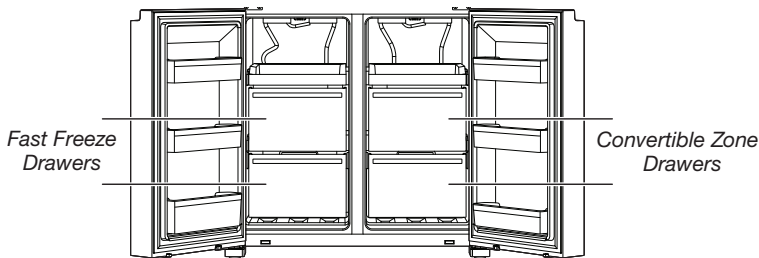

Fast Freeze compartment

- Use this drawers to freeze a bigger amount of fresh or cooked food (in the best or in the fastest way).
- Fast Freeze option allows you to store all your frozen food safely and transparently.

NOTE: Freezer temperature might be cooled down to be same as Flexible Freezer Compartment temperature, when Freezer set to warmer than Flexible Freezer compartment.

Convertible Zone

- Use this drawers to freeze a bigger amount of fresh or cooked food (in the best or in the fastest way)
- Use Convertible Zone to store all kinds of food in the ideal preservation environment. Adjusting the settings it can be used to store wine (10°C), fruits and veggies (4°C), Meat and fish (0°C), weekly meals (-7°C), ice cream and desserts (-12°C) and hard freeze food (-16°C or less).

Refrigerator Door Bins

The bins on your refrigerator door are removable to meet your individual storage needs.

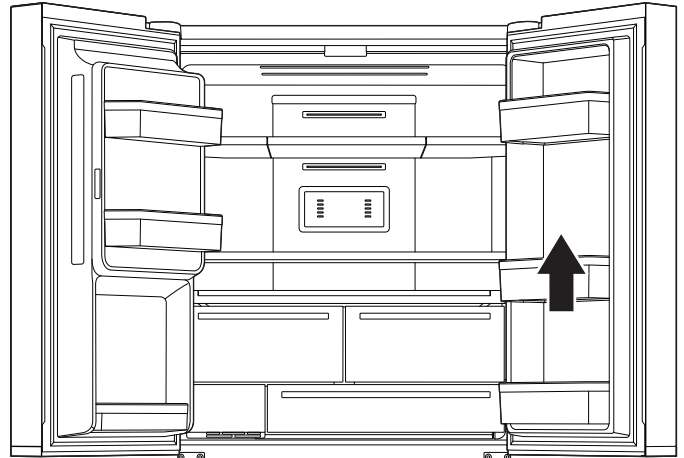

For maximum freezer capacity, you may remove the freezer drawer to expose the freezer shelf.

To remove the upper drawer:

1. Grasp handle of the drawer and slide drawer straight out to the stop. Lift drawer off the bottom guide.
2. Replace/putting back drawer stop into position.

REFRIGERATOR CARE

Cleaning

⚠ WARNING



Explosion Hazard

Use nonflammable cleaner.

Failure to do so can result in death, explosion, or fire.

All of the Refrigerator, Freezer and Convertible Zone sections defrost automatically. However, clean all the sections about once a month to avoid build-up of odours. Wipe up spills immediately.

Exterior Cleaning

Please see the exterior cleaning information specific to your model.

Fingerprint-Resistant Stainless

IMPORTANT:

- Avoid exposing stainless steel appliances to caustic or corrosive elements such as high-salt, high-moisture, or high-humidity environments. Damage due to exposure to these elements is not covered under the warranty.

DO USE	DO NOT USE
<ul style="list-style-type: none"> ✓ Soft, clean cloth 	<ul style="list-style-type: none"> ✗ Abrasive cloths ✗ Paper towels or newsprint ✗ Steel-wool pads
<ul style="list-style-type: none"> ✓ Warm, soapy water with a mild detergent 	<ul style="list-style-type: none"> ✗ Abrasive powders or liquids ✗ Window sprays ✗ Ammonia ✗ Acidic or vinegar-based cleaners ✗ Oven cleaners ✗ Flammable fluids

NOTES:

- If unintentional contact does occur, clean plastic part with a sponge and mild detergent in warm water. Dry thoroughly with a soft cloth.
- Just because a cleaner is a liquid does not mean it is non-abrasive. Many liquid cleansers formulated to be gentle on tile and smooth surfaces still damage stainless steel.
- Citric acid permanently discolours stainless steel.
- To avoid damaging the finish of your stainless steel refrigerator:

Do not allow these substances to remain on the finish:

- ✗ Mustard
- ✗ Tomato juice
- ✗ Marinara sauce
- ✗ Citrus-based sauces
- ✗ Citrus-based products

Interior Cleaning

IMPORTANT: Refrigerator shelves with under-shelf, LED lighting are not dishwasher safe.

1. Unplug refrigerator or disconnect power.
2. Hand wash, rinse, and dry removable parts and interior surfaces thoroughly. Use a clean sponge or soft cloth and a mild detergent in warm water.

NOTE: Do not use abrasive or harsh cleaners such as window sprays, scouring cleansers, flammable fluids, cleaning waxes, concentrated detergents, bleaches, or cleansers containing petroleum products on plastic parts, interior and door liners, or gaskets.

3. Plug in refrigerator or reconnect power.

Condenser

This refrigerator has skin condenser on both sides of refrigerator. It is normal to feel warm on the sides.

Lights

The lights in both the fresh food and freezer compartments are LEDs which do not need to be replaced. If the lights do not illuminate when the door is opened, contact the dealer from whom you purchased your refrigerator.

Holiday and Moving Care

Holidays

If You Choose to Leave the Refrigerator On While You're Away:

1. Use up any perishables and freeze other items.
2. If your refrigerator has an automatic ice maker and is connected to the household water supply, turn off the water supply to the refrigerator. Property damage can occur if the water supply is not turned off.
3. If you have an automatic ice maker, turn off the ice maker.
 - Press the switch to Off (O) for the door ice maker.
4. Empty the ice bin.

If You Choose to Turn Off the Refrigerator Before You Leave:

NOTE: Put refrigerator in Demo Mode while on Holiday. See the "Using the Controls" section.

1. Remove all food from the refrigerator.
2. If your refrigerator has an automatic ice maker:
 - Turn off water supply to the ice maker at least 1 day ahead of time.
 - When last load of ice drops, press the switch to Off (O) for display to be unlit on the top inside of the refrigerator, depending on your model.
3. Empty ice bin.
4. Turn off temperature controls. See the "Using the Controls" section.
5. Clean refrigerator, wipe it and dry well.
6. Tape rubber or wood blocks to the tops of both doors to prop them open far enough for air to get in. This stops odours and mould from building up.

Moving

When you are moving your refrigerator to a new home, follow these steps to prepare it for the move.

1. If your refrigerator has an automatic ice maker:
 - Turn off water supply to the ice maker at least 1 day ahead of time.
 - Disconnect water line from the back of the refrigerator.
 - When last load of ice drops, press the switch to Off (O) either on the ice maker or the control, depending on your model.
2. Remove all food from refrigerator and pack all frozen food in dry ice.
3. Empty ice bin.
4. Unplug refrigerator.

5. Clean, wipe and dry thoroughly.
6. Take out all removable parts, wrap them well and tape them together so they don't shift and rattle during the move.
7. Depending on the model, raise the front of the refrigerator so it rolls more easily or raise the levelling screws so they do not scrape the floor. See the "Adjust the Doors" or "Refrigerator Levelling and Door Closing" sections.
8. Tape doors closed and tape the power cable to the back of the refrigerator.

When you get to your new home, put everything back and refer to the "Installation Instructions" section for preparation instructions. Also, if your refrigerator has an automatic ice maker, remember to reconnect the water supply to the refrigerator.

TROUBLESHOOTING - CONNECTED MODELS

First try the solutions suggested here. If you need further assistance or more recommendations that may help you avoid a service call, refer to the warranty page in this manual.

Please include a daytime phone number in your correspondence.

Connection Status	Control Panel Indicator Lights
Refrigerator is not connected.	Wi-Fi White icons are both OFF.
Refrigerator is attempting to connect to home Wi-Fi router.	Wi-Fi White icon is blinking fast.
Refrigerator connected to home Wi-Fi router and is attempting to connect to Hotpoint Cloud.	Wi-Fi White icon is blinking slowly. Wi-Fi Orange icon is ON.
Refrigerator is connected to home Wi-Fi router, but not connected to the Hotpoint cloud. Hotpoint [®] app does not work.	Wi-Fi White icon is blinking slowly. Wi-Fi Orange icon is ON.
Refrigerator is connected to home Wi-Fi router and the Wi-Fi icon is ON. Hotpoint [®] app works.	Wi-Fi White icon is ON.
Refrigerator is connected to home Wi-Fi router and the Wi-Fi icon is ON. Refrigerator is in the process of a software update. Hotpoint [®] app works.	Wi-Fi White icon is ON and flashing continuously while software updates.

If you experience	Possible Causes	Solution
Refrigerator is not connected to home Wi-Fi router. (Wi-Fi icon is OFF.)	The refrigerator may be in Standby mode.	Touch and hold Connect button together for 3 seconds to see the Wi-Fi icon blinking, then lights are ON solid. All indicator lights are OFF when in Standby mode.
	The refrigerator has never been connected to the home Wi-Fi router.	See the "Connectivity Setup" section.
	Lost connection to home Wi-Fi router .	Check whether the router is ON and working with other computers or devices in the home (able to access the Internet).
	Weak signal strength or signal interference between the refrigerator and router.	Try to place the wireless router closer to the refrigerator. It may be necessary to install a Wi-Fi range extender.
	The refrigerator is already connected to another WiFi Router.	See the "Connectivity Setup" section to disconnect the Refrigerator from the Wifi router and try reconnecting again.
Wi-Fi icon does not light at all after touching and holding CONNECT.	Something may be wrong with the refrigerator.	Unplug or disconnect refrigerator power for 30 seconds. Return power. Repeat Wi-Fi connecting process.
		Verify that the refrigerator operates correctly, except for not being able to connect. Call for possible additional troubleshooting.
Refrigerator is connected to home Wi-Fi router, but Hotpoint [®] app does not work.	Connection to the Hotpoint [®] app may be unavailable.	Check Internet.
	User account has not been properly set up or the refrigerator has not been registered in an account.	See the "Connectivity Setup" section or the Hotpoint [®] app directly for account setup and refrigerator registration instructions.
		Verify that the refrigerator is paired with your account in the app.
		Verify correct email address, mobile number, and notification preferences.
Router is not connected to Internet.	Check other devices connected to Internet through same router.	
Check other devices connected to Internet through same router.	Wi-Fi disconnected.	Touch and hold Connect button for 3 seconds to enable Wi-Fi. Power off service breaker for 30 or more seconds, power back on, and then use alternate set-up instructions available in the Hotpoint mobile App.

TROUBLESHOOTING

First try the solutions suggested here to possibly avoid a service call.

⚠ WARNING



Electrical Shock Hazard

Plug into a grounded 3 prong outlet.

Do not remove ground prong.

Do not use an adapter.

Do not use an extension cord.

Failure to follow these instructions can result in death, fire, or electrical shock.

If you experience	Possible Causes	Solution
Refrigerator Operation		
The refrigerator will not operate.	Check electrical supply.	Plug the power cable into an earthed socket. Do not use an extension cable. Make sure there is power to the socket. Plug in a lamp to see if the socket is working. Reset a tripped circuit breaker. Replace any blown fuses. NOTE: If problems continue, contact an electrician.
	Check controls.	Make sure the controls are turned on. See the “Using the Controls” section.
	New installation.	Allow 24 hours following installation for refrigerator to cool completely. NOTE: Adjusting the temperature controls to the coldest setting will not cool either compartment more quickly.
	Refrigerator control is in Demo mode (on some models).	If refrigerator is in Demo mode, cooling is turned off and “Demo” will be illuminated on the control panel. See the “Using the Controls” section for more information.
	The motor seems to run too much.	High-efficiency compressor and fans.
The room or outdoor temperature is hot.		It is normal for refrigerator to work longer under these conditions. For optimum performance, place refrigerator in an indoor, temperature-controlled environment. See the “Location Requirements” section.
A large amount of warm food has been recently added.		Warm food will cause refrigerator to run longer until the air cools to the desired temperature.
The door(s) are opened too frequently or for too long.		Warm air entering refrigerator causes it to run more. Open the door less often.
The refrigerator door or freezer drawer is open.		Make sure refrigerator is level. See the “Refrigerator Levelling and Door Closing” section. Keep food and containers from blocking the door.
The refrigerator control is set too cold.		Adjust refrigerator control to a less-cold setting until the refrigerator temperature is as desired.
The door or drawer gasket is dirty, worn, or cracked.		Clean or change the gasket. Leaks in the door seal will cause refrigerator to run longer in order to maintain desired temperatures.

TROUBLESHOOTING

First try the solutions suggested here to possibly avoid a service call.

If you experience	Possible Causes	Solution
The lights do not work.	Your refrigerator is equipped with LED lighting which does not need to be replaced.	If there is power to the refrigerator and the lights do not illuminate when a door or drawer is opened, call for service or assistance.
	Doors have been open longer than 10 minutes.	Close the doors and drawer to reset and open to resume lighted task.
	The door switch is not sensing the door opening.	Ensure there are no magnets or electronic devices within 7.6 cm (3") of the hinge cover.
The Temperature Control UI does not turn on.	The Temperature Control UI went to sleep.	Press any button on the UI to wake up the The Temperature Control UI.
	The Temperature Control UI buttons are not working well.	Try cycling power on the refrigerator to make the buttons reset. If problem continuous, call for service or assistance.
	The Temperature Control UI is not receiving power.	Check the wiring harness at the door hinge.
Unable to adjust setting on The Temperature Control UI.	Door is open and Door ajar alarm is activated.	Close the door.
Unusual Noise		
To listen to normal refrigerator sounds, go to the Product Help/FAQ section of the brand website and search for "normal sounds." Below are listed some normal sounds with explanations.		
The refrigerator seems noisy.	The compressor in your new refrigerator regulates temperature more efficiently while using less energy and operates quietly.	Due to this reduction in operating noise, you may notice unfamiliar noises that are normal.
Sound of the compressor running longer than expected.	High-efficiency compressor and fans.	Larger, more-efficient refrigerators run longer at lower, more energy efficient speeds.
Pulsating/Whirring	Fans/compressor adjusting to optimize performance during normal compressor operation.	This is normal.
Popping	Contraction/expansion of inside walls, especially during initial cool down.	This is normal.
Hissing/Dripping	Flow of refrigerant or flow of oil in the compressor.	This is normal.
Vibration	The refrigerator may not be steady.	Adjust the levelling screws and lower the levelling foot firmly against the floor. See the "Refrigerator Levelling and Door Closing" section.
Sizzling	Water dripping on the heater during Defrost cycle.	This is normal.
Water running/Gurgling	May be heard when ice melts during the Defrost cycle and water runs into the drain pan.	This is normal.

TROUBLESHOOTING

First try the solutions suggested here to possibly avoid a service call.

If you experience	Possible Causes	Solution
Temperature and Moisture		
Temperature is too warm.	The refrigerator has just been installed.	Allow 24 hours following installation for refrigerator to cool completely.
	The controls are not set correctly for the surrounding conditions.	Adjust the controls a setting colder. Check the temperature in 24 hours. See the "Using the Controls" section.
	The door(s) are opened often or not closed completely. Allows warm air to enter refrigerator.	Minimize door openings and keep doors fully closed.
	A large load of food was recently added.	Allow several hours for refrigerator to return to normal temperature.
	Demo mode is on.	Turn off the Demo mode. See the "Using the Control" section.
	Holiday mode is on.	Turn off the Holiday mode. See the "Using the Control" section.
Temperature is too cold in the refrigerator/crisper.	The refrigerator air vent(s) are blocked.	If the air vent located in the middle rear of the fresh food compartment is blocked by items placed directly in front of it, the refrigerator will get too cold. Move items away from the air vent.
	The controls are not set correctly for the surrounding conditions.	Adjust the controls a setting warmer. Check the temperature in 24 hours. See the "Using the Controls" section.
Temperature is too cold in the temperature controlled drawer.	The control is not set correctly for the items stored in drawer.	Adjust the temperature setting. See the "Using the Controls" in the "Refrigerator Use" section.
There is interior moisture build-up. NOTE: Some moisture build-up is normal.	The room is humid.	A humid environment contributes to moisture build-up.
	The door(s) are opened often or not closed completely. Allows humid air to enter the refrigerator.	Minimize door openings and close doors completely.
	The door(s) are blocked open.	Move food packages away from door.
	A bin or shelf is in the way.	Push bin or shelf back into the correct position.
	Storing liquid in open containers.	This adds humidity to refrigerator interior. Keep all containers tightly covered.
There is frost/ice build-up in the freezer compartment.	The door is opened often or left open.	Minimize door openings and close drawer completely after use.
	The door has poor door seal.	Ensure door seals are making full contact with the refrigerator cabinet to allow for an adequate seal.
	Temperature controls are not set correctly.	See the "Using the Controls" section for recommended temperature settings.

TROUBLESHOOTING

First try the solutions suggested here to possibly avoid a service call.

If you experience	Possible Causes	Solution
Ice and Water		
The ice maker is not producing ice or is not producing enough ice.	The refrigerator is not connected to a water supply or the water supply shut-off valve is not turned on.	Connect refrigerator to water supply and turn water shut-off valve to fully open.
	There is a kink in the water source line.	A kink in the line can reduce water flow. Straighten the water source line.
	The ice maker is not turned on.	Make sure the ice maker is ON. See the "Ice Maker and Storage Bin" section.
	The refrigerator has just been installed.	Wait 24 hours after ice maker installation for ice production to begin. Wait 3 days for full ice production.
	The refrigerator door is not closed completely.	Close the door firmly. If it does not close completely, see "The doors will not close completely" in this table.
	A large amount of ice was recently removed.	Allow sufficient time for ice maker to produce more ice. See the "Ice Maker and Storage Bin" section for ice production rates.
The ice cubes are hollow or small. NOTE: This is an indication of low water pressure.	The water shut-off valve is not fully open.	Turn the water shut-off valve fully open.
	There is a kink in the water source line.	A kink in the line can reduce water flow. Straighten the water source line.
	A water filter is installed on the refrigerator.	Remove filter and operate ice maker. If ice quality improves, then the filter may be clogged or incorrectly installed. Replace filter or reinstall it correctly.
	A reverse osmosis water filtration system is connected to the cold water supply.	This can decrease water pressure. See the "Water Supply Requirements" section.
	Questions remain regarding water pressure.	Call a licensed, qualified plumber.
Off-taste, odor, or gray color in the ice or water	Newly installed refrigerator requires flush of water system.	Flush the water system. See the "Water and Ice Dispensers" section for water system flushing instructions.
	Recently installed or replaced plumbing connections. New plumbing connections can cause discolored or off-flavored ice and water.	Discard ice and wash the ice storage bin. Flush the water system with 3 gal. (12 L) of water. Allow 24 hours for the ice maker to make new ice and discard the first 3 batches of ice produced.
	Using a water supply connection type other than recommended	It is recommended to use copper tubing or Hotpoint [®] supply line, Part Number 8212547RP. See the "Connect the Water Supply" section.
	The ice has been stored too long.	Discard ice and wash ice storage bin. Allow 24 hours for ice maker to make new ice.
	The water has been stored too long.	Dispense at least 1 qt (1 L) of water per week to maintain a fresh supply.
	Odor from stored food has transferred to the ice.	Use airtight, moisture-proof packaging to store food.
	There are minerals (such as sulfur) in the water.	A water filter may need to be installed to remove the minerals.
	There is a water filter installed on the refrigerator.	Gray or dark discoloration in ice may indicate that the water filtration system needs additional flushing. Flush the water system after installing and before using a new water filter. See the "Water and Ice Dispensers" section for water filter flushing instructions.
	The water filter needs to be replaced.	Replace the disposable water filter at least every 6 months or when indicated. See the "Water Filtration System" section.

TROUBLESHOOTING

First try the solutions suggested here to possibly avoid a service call.

If you experience	Possible Causes	Solution
Ice and Water (cont.)		
The water and ice dispenser will not operate properly.	The refrigerator is not connected to a water supply or the water supply shut-off valve is not turned on.	Connect the refrigerator to the water supply, and turn the water shut-off valve to fully open.
	There is a kink in the water source line.	A kink in the water line can reduce water flow from the water dispenser and result in hollow or irregular shaped ice. Straighten the water source line.
	The refrigerator has just been installed.	Flush and fill the water system. See the "Water and Ice Dispensers" section.
	The water pressure to the house is not at or above 35 psi (241 kPa).	The water pressure to the house determines the flow from the dispenser. See the "Water Supply Requirements" section.
	A reverse osmosis water filtration system is connected to the cold water supply.	A reverse osmosis water filtration system can decrease water pressure. See the "Water Supply Requirements" section.
	The water filter may be clogged.	Remove the water filter and operate dispenser. If water flow increases, your filter is clogged and needs to be replaced. See the "Water Filtration System" section.
	The water filter is installed incorrectly.	Remove the water filter and reinstall. See the "Water Filtration System" section.
The water and ice dispenser will not operate properly. (cont.)	The refrigerator door or freezer drawer is not closed completely.	Close the door or drawer firmly. If it does not close completely, see "The doors will not close completely."
	The refrigerator doors were recently removed.	Make sure the water dispenser wire/tube assembly has been properly reconnected at the top of the refrigerator door. See the "Remove and Replace Refrigerator Doors" section.
	Ice is clogged in the ice storage bin or ice is blocking the ice delivery chute.	Remove the ice clogging the storage bin and delivery chute, using a plastic utensil if necessary. Clean the ice delivery chute and the bottom of the ice storage bin using a warm, damp cloth, then dry both thoroughly. To avoid clogging and to maintain a fresh supply of ice, empty the storage bin and clean both the storage bin and delivery chute every 2 weeks.
Ice bin is difficult to remove from door.	Ice level in bin may be high and uneven from normal ice production and augering of ice during dispensing.	Dispense 2-3 glasses of ice, then try removing the ice bin.
The ice dispenser jams while dispensing crushed ice.	Crushed ice is blocking the ice delivery chute.	Switch from crushed ice to cubed ice to clear the ice dispenser. Then switch back to crushed ice.
Water is leaking or dripping from the dispenser system. NOTE: A few drops of water after dispensing is normal.	The glass was not held under the dispenser long enough.	Hold the glass under the dispenser 2 to 3 seconds after releasing the dispenser lever.
Ice continues to flow from the dispenser. NOTE: A few cubes dispensed after releasing the dispenser lever is normal.	The glass was not held under the dispenser long enough.	Hold the glass under the dispenser 2 to 3 seconds after releasing the dispenser lever.

TROUBLESHOOTING

First try the solutions suggested here to possibly avoid a service call.

If you experience	Possible Causes	Solution
Ice and Water (cont.)		
Water continues to drip from the dispenser beyond the first few drops.	The refrigerator has just been installed.	Flushing the water system removes the air from the lines which causes the water dispenser to drip. Flush the water system. See the “Water and Ice Dispensers” section.
	The water filter was recently installed or replaced.	Flushing the water system removes the air from the lines which causes the water dispenser to drip. Flush the water system. See the “Water and Ice Dispensers” section
	There may be a loose water connection.	Check for water in bottom of refrigerator compartment, hinge area, or by household connection in back of product.
Water is leaking from the back of the refrigerator.	The water line connections were not fully tightened.	See the “Connecting the Water” section.
	Recently removed the doors and did not fully tighten water line connection.	See the “Remove and Replace Refrigerator Doors” section.
Crushed or cubed ice misses the glass when dispensing ice.	The glass is not held close enough to where the ice exits the chute.	Hold the glass close to where the ice exits the chute.
Water from the dispenser is warm.	Water from the dispenser is chilled to 50°F (10°C).	This is normal.
	The refrigerator has just been installed.	Allow 24 hours after installation for the water supply to cool completely.
	A large amount of water was recently dispensed.	Allow 3 hours for the water supply to cool completely.
	Water has not been recently dispensed.	The first glass of water may not be cool. Discard the first glass of water dispensed.
	The refrigerator is not connected to a cold water pipe.	Make sure the refrigerator is connected to a cold water pipe. See the “Water Supply Requirements” section.

TROUBLESHOOTING

First try the solutions suggested here to possibly avoid a service call.

⚠ WARNING

<p>Explosion Hazard</p> <p>Use nonflammable cleaner.</p> <p>Failure to do so can result in death, explosion, or fire.</p>

To view an animation showing how to adjust and align the doors, refer to the Product Help/FAQ section of the brand website and search for “Door Closing and Door Alignment.”

If you experience	Possible Causes	Solution
Doors		
The doors will not close completely.	The door is blocked open.	Move food packages away from door.
	A bin or shelf is in the way.	Push bin or shelf back into the correct position.
	Recently installed	Remove all packaging materials.
The doors are difficult to open.	The door gaskets are dirty or sticky.	Clean gaskets and contact surfaces with mild soap and warm water. Rinse and dry with soft cloth.
The doors appear to be uneven.	The doors need to be aligned or the refrigerator needs to be levelled.	If you need to align door please call for service.
The refrigerator is unsteady or it rolls forward when opening and closing doors.	The refrigerator brake feet are not snug against the floor.	Turn both brake feet (one on each side) counterclockwise, the same amount, until they are snug against the floor. See the “Refrigerator Levelling and Door Closing” section.

PERFORMANCE DATA SHEET

Water Filtration System Model P9WB2L/P9RFWB2L/EDR2RXD1 Capacity 200 Gallons (757 Liters)



System tested and certified by NSF International against NSF/ANSI Standard 42, Standard 53, Standard 401, and CSA B483.1 for the reduction of contaminants specified on the Performance Data Sheet.

This system has been tested according to NSF/ANSI Standards 42, 53, 401, and CSA B483.1 for the reduction of the substances listed below. The concentration of the indicated substances in water entering the system was reduced to a concentration less than or equal to the permissible limit for water leaving the system, as specified in NSF/ANSI Standards 42, 53, 401, and CSA B483.1. This system has been tested according to Ministerial Decree No 174, article 9 of legislative decree n 31 of 2001, Regulations (EC) no 1935/2004, WRAS BS6920 and ACS Circulaire 2002/571.

Substance Reduction Aesthetic Effects	Influent Challenge Concentration	Maximum Permissible Product Water Concentration	Average% Reduction
Chlorine Taste/Odor Particulate Class I*	2.0 mg/L ± 10% At least 10,000 particles/mL	50% reduction 85% reduction	97.2% 99.5%
Contaminant Reduction	Influent Challenge Concentration	Maximum Permissible Product Water Concentration	Average%Reduction
Lead: @ pH 6.5/ @ pH 8.5	0.15 mg/L ± 10%	0.010 mg/L	>99.3% / 98.6%
Benzene	0.015 mg/L ± 10%	0.005 mg/L	96.0%
p - Dichlorobenzene	0.225 mg/L ± 10%	0.075 mg/L	>99.8%
Carbofuran	0.08 mg/L ± 10%	0.040 mg/L	91.9%
Toxaphene	0.015 ± 10%	0.003 mg/L	93.3%
Atrazine	0.009 mg/L ± 10%	0.003 mg/L	92.4%
Asbestos	10 ⁷ to 10 ⁸ fibers/L ^{††}	99%	>99%
Asbestos	50,000/L min.	99.95%	>99.99%
Live Cyst [†]	11 NTU ± 10%	0.5 NTU	99.0%
Lindane	0.002 ± 10%	0.0002 mg/L	98.9%
Tetrachloroethylene	0.015 mg/L ± 10%	0.005 mg/L	>96.6%
O-Dichlorobenzene	1.8 mg/L ± 10%	0.60 mg/L	>99.9%
Ethylbenzene	2.1 mg/L ± 10%	0.70 mg/L	99.4%
1,2,4-Trichlorobenzene	0.210 mg/L ± 10%	0.07 mg/L	>99.8%
2,4 - D	0.210 mg/L ± 10%	0.07 mg/L	93.8%
Styrene	2.0 mg/L ± 10%	0.1 mg/L	99.8%
Toluene	3.0 mg/L ± 10%	1.0 mg/L	87.9%
Endrin	0.006 mg/L ± 10%	0.002 mg/L	>96.6%
Atenolol	200 ± 20%	30 ng/L	>95.9%
Trimethoprim	140 ± 20%	20 ng/L	>96.9%
Linuron	140 ± 20%	20 ng/L	>96.4%
Estrone	140 ± 20%	20 ng/L	>97.0%
Nonylphenol	1400 ± 20%	200 ng/L	>97.4%
Carbamazepine	1400 ± 20%	200 ng/L	>97.9%
Phenytoin	200 ± 20%	30 ng/L	93.8%
Naproxen	140 ± 20%	20 ng/L	96.1%
Bisphenol A	2000 ± 20%	300 ng/L	>99.2%

Test Parameters: pH = 7.5 ± 0.5 unless otherwise noted. Flow = 0.6 gpm (2.27 Lpm). Pressure = 60 psig (413.7 kPa). Temp. = 68°F to 71.6°F (20°C to 22°C). Rated service capacity = 200 gallons (757 liters).

The compounds certified under NSF 401 have been deemed as “emerging compounds/incidental contaminants.” Emerging compounds/incidental contaminants are those compounds that have been detected in drinking water supplies at trace levels. While occurring at only trace levels, these compounds can affect the public acceptance/perception of drinking water quality.

- It is essential that operational, maintenance, and filter replacement requirements be carried out for the product to perform as advertised. Property damage can occur if all instructions are not followed.
- The disposable cartridge must be changed at least every 6 months.
- Use replacement filter P9RFWB2L, part #EDR2RXD1/EDR2RXD1B. 2015 suggested retail price of \$49.99 U.S.A./\$49.99 Canada. Prices are subject to change without notice.
- The filter monitor system measures the amount of water that passes through the filter and alerts you when it is time to replace the filter. Refer to the “Using the Controls” or “Water Filtration System” section (in the User Instructions or User Guide) to learn how to check the water filter status.
- After changing the water filter, flush the water system. See “Water and Ice Dispensers” or “Water Dispenser” in the User Instructions or User Guide.

- These contaminants are not necessarily in your water supply. While testing was performed under standard laboratory conditions, actual performance may vary.
- The product is for cold water use only.
- The water system must be installed in compliance with state and local laws and regulations.
- Do not use with water that is microbiologically unsafe or of unknown quality without adequate disinfection before or after the system. Systems certified for cyst reduction may be used on disinfected waters that may contain filterable cysts. EPA Est. No. 082047-TWN-001
- Refer to the "Warranty" section (in the User Instructions or User Guide) for the Manufacturer's limited warranty, name and telephone number.
- The refrigerator when dispensing water acts as drinking water treatment equipment.
- This equipment requires regular periodic maintenance in order to guarantee the drinking water treatment requirements and the maintenance of the improvements every 6 months.

Application Guidelines/Water Supply Parameters

Water Supply	Potable City or Well
Water Pressure	30 - 120 psi (207 - 827 kPa)
Water Temperature	33° - 100°F (0.6° - 37.8°C)
Service Flow Rate	0.6 GPM (2.27 L/min.) @ 60 psi (413.7 kPa)

- Your water filtration system will withstand up to 120 pounds per square inch (psi) water pressure. If your water supply is higher than 80 psi, install a pressure reducing valve before installing the water filtration system.

