

ADG 480 IX

12NC: 851148001010

EAN code: 8003437245121



SENSING THE DIFFERENCE

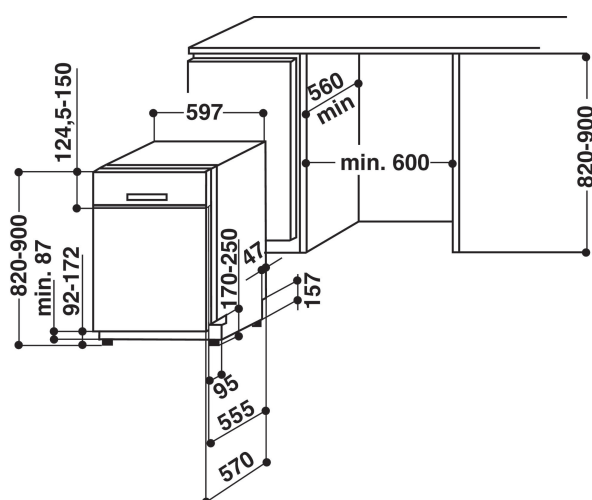

MAIN FEATURES

Construction type	Built-in
Installation type	Half-integrated
Type of control	Mechanical and electronic
Type of control setting and signalling devices	7 segments
Removable work top	N/A
Door decor panel	N/A
Main colour of product	Nerez
Connection rating (W)	2200
Current (A)	10
Voltage (V)	220-230
Frequency (Hz)	50
Length of Electrical Supply Cord (cm)	150
Plug type	Schuko
Length inlet hose (cm)	150
Ledningslængde (cm)	200
Adjustable plinth	Ne
Height of removable worktop (mm)	0
Adjustable feet	Yes - all from front
Height of the product	820
Width of the product	597
Depth of the product	570
Depth with open door 90 degree (mm)	1150
Minimum niche height	820
Maximum niche height	900
Minimum niche width	600
Maximum niche width	600
Niche depth	570
Net weight (kg)	43
Gross weight (kg)	44.20

TECHNICAL FEATURES

Automatic programmes	Ano
Maximum temperature for water intake (°C)	60
Start delay options	Continuous
Start delay time max. (h)	24
Progress indicator	Ano
Digital countdown indicator	Ano
Salt light indicator	Ano
Rinse aid light indicator	Ano
Safety device	Ano
Adjustable upper basket	Ano
Largest loadable dish upper basket (cm)	0
Largest loadable dish lower basket (cm)	0

ENERGETICKÝ ŠTÍTEK

Energy efficiency class - NEW (2010/30/EC)	A++
Energy consumption annual (kWh/annum) - NEW (2010/30/EC)	262
Duration of the left-on mode - NEW (2010/30/EC)	3
Power consumption in left-on mode - NEW (2010/30/EC)	1.50
Power consumption in off-mode - NEW (2010/30/EC)	0.50
Water consumption annual (l/annum) - NEW (2010/30/EC)	2800
Noise level (dB(A) re 1 pW)	48