

ARG 18480 A+

12NC: 853417796000

GTIN (EAN) code: 8003437041440

Whirlpool

SENSING THE DIFFERENCE

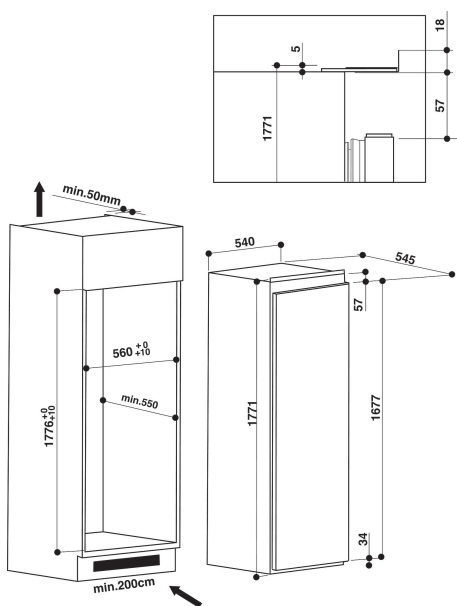

MAIN FEATURES

Product group	Chladnický
Commercial code	ARG 18480 A+
GTIN (EAN) code	8003437041440
Construction type	Built-in
Installation type	Plne vestavná
Type of control	Electronic
Type of control settings	7 segments
Main colour of product	White
Electrical connection rating (W)	130
Current (A)	16
Voltage (V)	220-240
Frequency (Hz)	50
Length of Electrical Supply Cord (cm)	245
Plug type	Schuko
Total unit net capacity (l)	292
Star Rating	4
Number of independent cooling systems	1
Height of the product	1771
Width of the product	540
Depth of the product	545
Depth with open door 90 degree (mm)	-
Maximum adjustability feet	0
Net weight (kg)	51
Door hinge	Right reversible

TECHNICAL FEATURES

Temperature adjustable	Ano
Warning signal / Malfunction	Visual
Defrost process fridge section	Automatic
Fast cooling possibility	Ne
Interior ventilator fridge section	Ano
Shelves for Bottles	Ano
Lockable door	-
Number of shelves in fridge compartment	6
Number of Adjustable Shelves in fridge compartment	5
Material of the shelves	Glass
Thermometer fridge section	None

ENERGETICKÝ ŠTÍTEK

Energy efficiency class - NEW (2010/30/EU)	A+
Energy consumption annual (kWh/annum) - NEW (2010/30/EU)	280
Refrigerator Net capacity (l) - NEW (2010/30/EU)	262
Freezer Net capacity (l) - NEW (2010/30/EU)	30
Freezing capacity (kg/24h) - NEW (2010/30/EU)	3
Temperature rise time (h)	16
Climate class	SN-T
Noise level (dB(A) re 1 pW)	36
Frost free system	Ne
Maximum ambient temperature	43
Minimum ambient temperature	10