

# WS Q0530 NE

12NC: 859991589810

GTIN (EAN) code: 8003437604850

# Whirlpool

SENSING THE DIFFERENCE

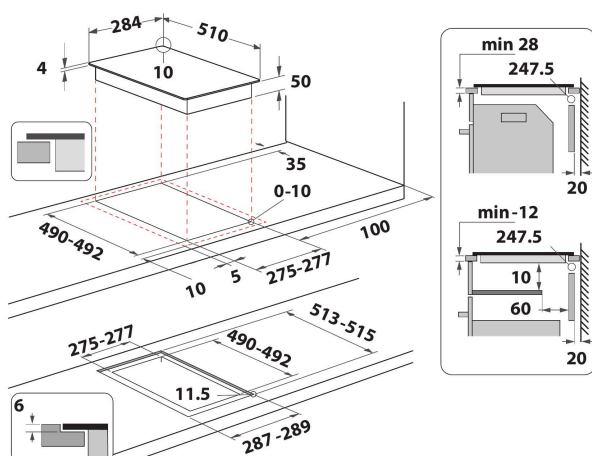

- 6TH Sense Technology
- 2 induction cooking zones
- Easy installation
- Pan Detection
- Residual heat indicator
- Child lock
- On/Off Switch
- Melting function
- Timer
- Black Glass Hob
- 2 Boosters
- 2 Plate on Indicator
- Total power declared: 3.7 kW
- Power on indicator
- Supply cord included
- Frameless
- Dimensions HxWxD: 54x284x510 mm

## Whirlpool induction glass-ceramic hob - WS Q0530 NE

2 induction rings. this Whirlpool induction glass-ceramic Hob features: An elegant technology, that heats the pan, not the hob, reducing energy dispersion and providing perfect cooking results. Electric power supply.



### 6TH SENSE AUTOMATIC FUNCTIONS

Setting the correct heat level is no longer an issue, thanks to 4 special pre-set functions - up to 4 for each cooking zone. Just select the program and the hob automatically sets the best heat level for the desired cooking method.



### Power management

Outstanding energy efficiency. With the Power Management function, you set the hob's power level, to avoid the risk of overloading the power supply in your home.



### Booster 3Kw

Enjoy ideal results, faster. This Whirlpool Hob features a 3Kw booster for faster, effective heating results.



### Melting

Perfect low-heat cooking. The Melting function allows you to cook at very low temperatures, providing you with the ideal solution for melting chocolate, butter or for cooking light, delicate sauces.



### Front Controls

Complete control over your cooking. Easily accessible and genuinely intuitive, the controls are conveniently positioned on the front panel of your hob, providing a frictionless cooking experience.



### Direct mapping

The new user interface allows a more intuitive interaction with the hob. It naturally maps the cooking zones to give consumers a clear understanding of controls for each zone.



### Touch control

Cooking at the press of a button. Thanks to TouchControl, the precise control of your hobs is at your finger tips. The sensor power regulation does without the 10 phases on most dials and thus allows for simpler cleaning and care for your hob.



### Boiling

Automatic Boiling Function



### Electronic Timer

Set the ideal time for your preparations based on the recipe's needs.

# WS Q0530 NE

12NC: 859991589810

GTIN (EAN) code: 8003437604850

**Whirlpool**

SENSING THE DIFFERENCE

## MAIN FEATURES

Product group	Hob
Construction type	Built-in
Type of control	Electronic
Type of control settings	-
Number of gas burners	0
Number of electric cooking zones	2
Number of electric plates	0
Number of radiant plates	0
Number of halogen plates	0
Number of induction plates	2
Number of electric warming zones	0
Location of control panel	Front
Basic surface material	Ceramic Glass
Main colour of product	Black
Electrical connection rating (W)	3700
Gas connection rating (W)	0
Gas type	N/A
Current (A)	16
Voltage (V)	220-240
Frequency (Hz)	50/60
Length of Electrical Supply Cord (cm)	120
Plug type	No
Gas connection	N/A
Width of the product	284
Height of the product	54
Depth of the product	510
Minimum niche height	28
Minimum niche width	275
Niche depth	490
Net weight (kg)	5.7
Automatic programmes	Yes

## TECHNICAL FEATURES

Power on indicator	Yes
Number of indicators	2
Type of regulation	Stepless energy regulated
Type of lid	Without
Residual heat indicator	Separate
Main on/off switch	Yes
Safety device	-
Timer	Yes

## PERFORMANCES

Energy input	Electric
--------------	----------