

AMW 498 WH

12NC: 858749801940

EAN code: 8003437391903



SENSING THE DIFFERENCE

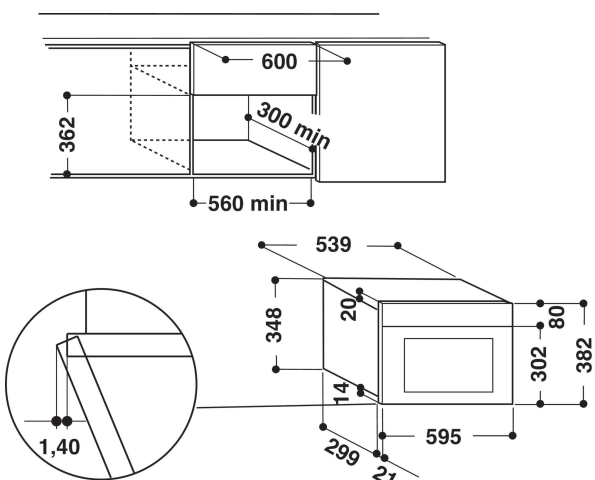

MAIN FEATURES

| | |
|--|-------------------|
| Product group | Microwave |
| Commercial code | AMW 498 WH |
| Main colour of product | White |
| Type of micro-wave oven | MW+Grill function |
| Construction type | Вбудована |
| Type of control | Electronic |
| Type of control setting and signalling devices | LED |
| Additional cooking method Grill | Yes |
| Crisp | Yes |
| Steam | Hi |
| Additional cooking method Fan cooking | Hi |
| Clock | Yes |
| Automatic programmes | Hi |
| Height of the product | 382 |
| Width of the product | 595 |
| Depth of the product | 320 |
| Minimum niche height | 360 |
| Minimum niche width | 556 |
| Niche depth | 300 |
| Net weight (kg) | 21 |
| Cavity capacity (l) | 22 |
| Turntable | Yes |
| Turntable diameter (mm) | 250 |
| Integrated Cleaning system | Hi |

TECHNICAL FEATURES

| | |
|---------------------------------------|---------------|
| Current (A) | 10 |
| Voltage (V) | 230 |
| Frequency (Hz) | 50 |
| Length of Electrical Supply Cord (cm) | 135 |
| Plug type | Schuko |
| Timer | Minute minder |
| Grill power (W) | 700 |
| Type of grill | Quartz |
| Cavity material | Painted |
| Interior light | Yes |
| Additional cooking method Grill | Yes |
| Position of interior lights | Right side |

ENERGY LABEL

| | |
|----------------------------------|-----|
| 6th Sense / Dynamic Intelligence | Hi |
| Number of power levels | 4 |
| Maximum micro-wave power (W) | 750 |
| Bread defrost | Hi |
| Jet defrost | Yes |
| Jet start | Yes |