

# AKPM 6580/IXL

12NC: 852565838110

GTIN (EAN) code: 8003437827563

Whirlpool

SENSING THE DIFFERENCE

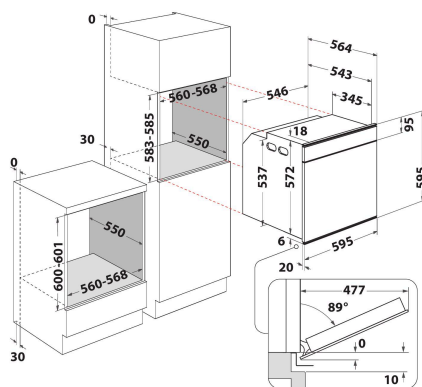

## MAIN FEATURES

Product group	Oven
Commercial code	AKPM 6580/IXL
Main colour of product	Nerez
Construction type	Vstavaná
Type of control	Mechanical
Type of control settings	-
Are any hobs controls integrated?	Nie
Which kind of hobs can be controlled?	-
Automatic programmes	Nie
Current (A)	13
Voltage (V)	220-240
Frequency (Hz)	50
Length of Electrical Supply Cord (cm)	90
Plug type	Nie
Depth with open door 90 degree (mm)	-
Height of the product	595
Width of the product	595
Depth of the product	564
Minimum niche height	0
Minimum niche width	0
Niche depth	0
Net weight (kg)	35.5
Usable volume (of cavity)	73
Integrated Cleaning system	Nie
Grids of the cavity	2
Trays	1

## TECHNICAL FEATURES

Timer	-
Time control	Mechanical
Time-setting options	Stop
Safety device	-
Interior light	Áno
Number of interior lights of the cavity	1
Position of interior lights of the cavity	Rear
Oven guides of the cavity	Grids
Probe of the cavity	Nie

## ENERGETICKÝ ŠTÍTOK

Energy input	Electric
Type of energy of the cavity	Elektrický
Energy efficiency class - NEW (2010/30/EU)	A
Energy consumption per cycle conventional - NEW (2010/30/EU)	0.91
Energy consumption per cycle forced air convection - NEW (2010/30/EU)	0.91