

WHCN 64 F LM X

12NC: 859991550040

GTIN (EAN) code: 8003437233586

Whirlpool

SENSING THE DIFFERENCE

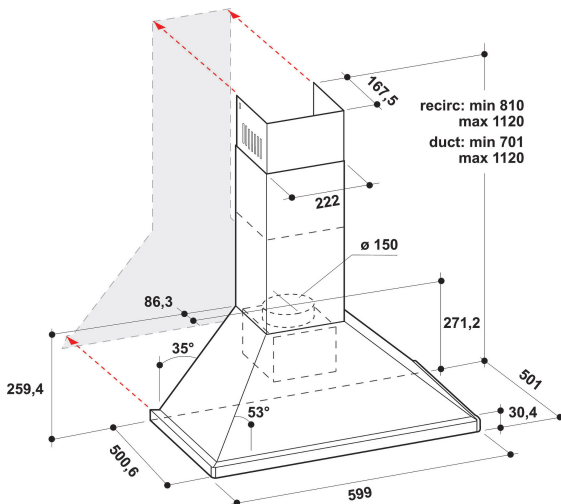

MAIN FEATURES

Product group	абсорбатори
Colour body	Инокс
Material body	Stainless steel
Colour chimney	N/A
Material chimney	N/A
Typology	Wall-mounted
Installation type	Wall-mounted
Type of control	Mechanical
Type of control settings	-
Decor panel options	N/A
Motor location	N/A
Operating Mode	Convertible
Electrical connection rating (W)	180
Current (A)	1,3
Voltage (V)	220-240
Frequency (Hz)	50/60
Length of Electrical Supply Cord (cm)	150
Plug type	Schuko
Chimney height (mm)	-
Height of product, without chimney (mm)	0
Height of the product	1120
Width of the product	599
Depth of the product	501
Minimum niche height	0
Minimum niche width	0
Niche depth	0
Net weight (kg)	12

TECHNICAL FEATURES

Type of manual control devices	Buttons
Type of automatic control devices	-
Number of motors	1
Total power of the motors (W)	175
Number of speed settings: boost option availability	3
Boost presence	No
Maximum output air extraction (m ³ /h)	603
Boost position air extraction (m ³ /h)	0
Maximum output recirculating air (m ³ /h)	400
Boost position output recirculating (m ³ /h)	0
Light Control Type	On/Off
Number of lights	2
Type of lamps used	LED
Total power of the lamps (W)	5
Diameter of air outlet (mm)	150
No-return airflow flap	No
Grease filter material	Washable aluminium
Odour filter	Yes

ENERGY LABEL

Sound power at min. speed (2010/30/EU)	47
Sound power at max. speed (2010/30/EU)	66
Noise level with boost position (dB(A) re 1 pW)	0