





1. Rapid hotplate Ø 180 - 2000 W
2. Normal hotplate Ø 145 - 1000 W
3. Rapid hotplate Ø 180 - 2000 W
4. Normal hotplate Ø 145 - 1000 W
5. Rapid hotplate control knob Ø 180 
6. Normal hotplate control knob Ø 145 
7. Rapid hotplate control knob Ø 180 
8. Normal hotplate control knob Ø 145 
9. Hotplate operation lamp 

Operation of electric hotplates

- Set the knob to one of positions 1-6, which correspond to different temperatures.
- To switch off the hotplate, set the knob to position "0".

DIMENSIONS OF COOKTOP AND WORKTOP

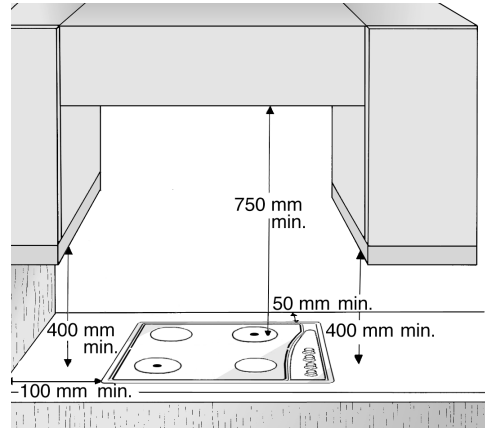
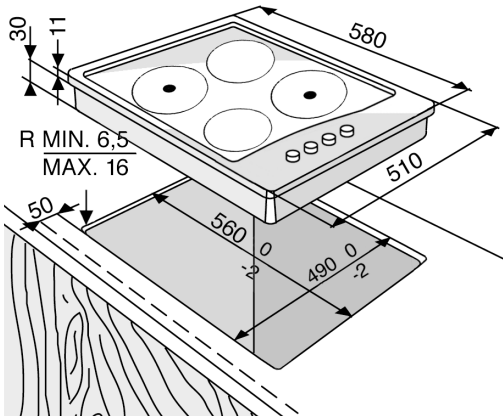

N.B.: In case of installation of a hood above the cooktop, please refer to the hood instructions for the correct distance.

SUPPLY VOLTAGE	CONDUCTORS: NUMBER AND SIZE	ELECTRICAL CONNECTION
230V ~ + ⊕	3 x 2.5 mm ²	1 2 3 ⊕ ○ ○ ○ L N
230V 3 ~ + ⊕	4 x 1.5 mm ²	1 2 3 ⊕ ○ ○ ○ ○ L1 L2 L3
400V 2N ~ + ⊕	4 x 1.5 mm ²	1 2 3 ⊕ ○ ○ ○ ○ L1 L2 N

TYPE: PLETP 230V~ / 400V 2N ~ 50Hz 6.0kW