

AKZ 6220 IX

12NC: 858562201700

GTIN (EAN) code: 8003437937903

Whirlpool

SENSING THE DIFFERENCE

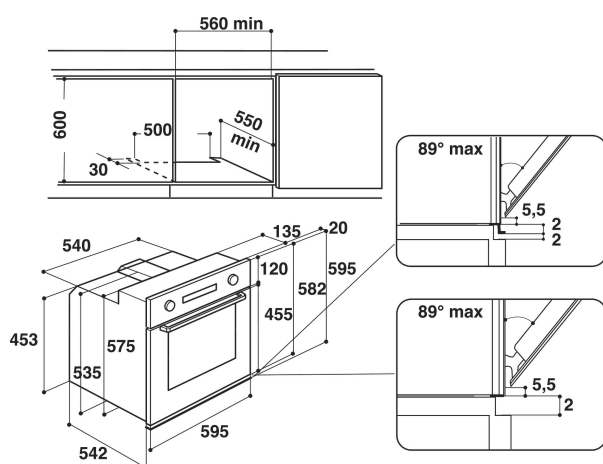

MAIN FEATURES

Product group	Pećnica
Commercial code	AKZ 6220 IX
Main colour of product	Inox
Construction type	Ugradbeni
Type of control	Mechanical and electronic
Type of control settings	-
Brončana	Ne
Which kind of hobs can be controlled?	-
Automatic programmes	Yes
Current (A)	16
Voltage (V)	220-240
Frequency (Hz)	50/60
Length of Electrical Supply Cord (cm)	130
Plug type	Ne
Depth with open door 90 degree (mm)	-
Height of the product	595
Width of the product	595
Depth of the product	564
Minimum niche height	0
Minimum niche width	0
Niche depth	0
Net weight (kg)	34
Usable volume (of cavity)	60
Integrated Cleaning system	Hydrolytic
Grids of the cavity	1
Trays	2

TECHNICAL FEATURES

Timer	-
Time control	Electronic
Time-setting options	Start and Stop
Safety device	-
Interior light	Yes
Number of interior lights of the cavity	1
Position of interior lights of the cavity	Rear
Oven guides of the cavity	Telescopic
Probe of the cavity	Ne

ENERGY LABEL

Energy input	Electric
Type of energy of the cavity	Electrică
Energy efficiency class - NEW (2010/30/EU)	A+
Energy consumption per cycle conventional - NEW (2010/30/EU)	0.87
Energy consumption per cycle forced air convection - NEW (2010/30/EU)	0.67