

ADG 6240 FD

12NC: 854262401000

EAN code: 8003437929298



SENSING THE DIFFERENCE

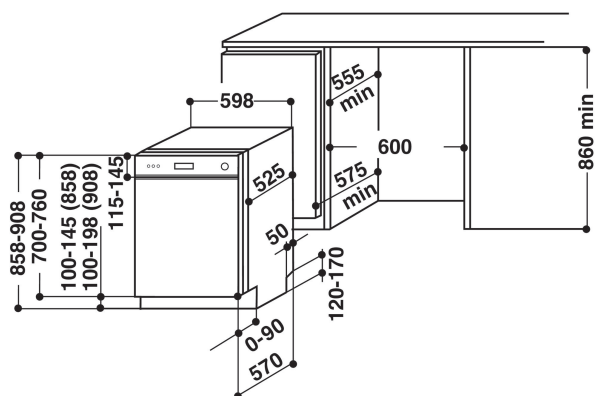

MAIN FEATURES

Construction type	Built-in
Installation type	Plne vestavná
Type of control	Mechanical and electronic
Type of control setting and signalling devices	7 segments
Removable work top	Ne
Door decor panel	N/A
Main colour of product	Černá
Connection rating (W)	2200
Current (A)	10
Voltage (V)	220-230
Frequency (Hz)	50
Length of Electrical Supply Cord (cm)	150
Plug type	Schuko
Length inlet hose (cm)	160
Ledningslængde (cm)	200
Adjustable plinth	Ne
Height of removable worktop (mm)	0
Adjustable feet	Yes - all from front
Height of the product	820
Width of the product	597
Depth of the product	555
Depth with open door 90 degree (mm)	1150
Minimum niche height	820
Maximum niche height	900
Minimum niche width	600
Maximum niche width	600
Niche depth	560
Net weight (kg)	41
Gross weight (kg)	42.20

TECHNICAL FEATURES

Automatic programmes	Ano
Maximum temperature for water intake (°C)	60
Start delay options	Continuous
Start delay time max. (h)	24
Progress indicator	Ano
Digital countdown indicator	Ano
Salt light indicator	Ano
Rinse aid light indicator	Ano
Safety device	N/A
Adjustable upper basket	Ano
Largest loadable dish upper basket (cm)	0
Largest loadable dish lower basket (cm)	0

ENERGETICKÝ ŠTÍTEK

Energy efficiency class - NEW (2010/30/EC)	A+
Energy consumption annual (kWh/annum) - NEW (2010/30/EC)	295
Duration of the left-on mode - NEW (2010/30/EC)	3
Power consumption in left-on mode - NEW (2010/30/EC)	1.50
Power consumption in off-mode - NEW (2010/30/EC)	0.50
Water consumption annual (l/annum) - NEW (2010/30/EC)	1680
Noise level (dB(A) re 1 pW)	42