

ART 195/63 A+/NF.1

12NC: 859991556840

GTIN (EAN) code: 8003437042898

Whirlpool

SENSING THE DIFFERENCE

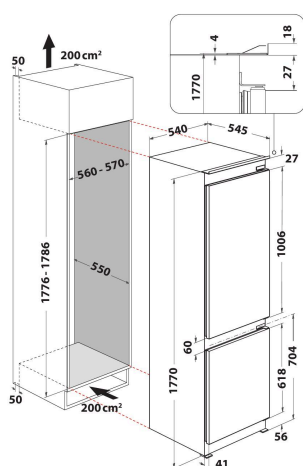

- Energy class A+
- 6TH Sense FreshControl
- Total net capacity: 258 l (195 l refrigerator + 63 l freezer)
- Product dimensions (HxWxD): 1770x540x545 mm
- Reversible door
- Noise level: 38 dB(A)
- No frost
- Fast freezing
- Climatic class SN-T
- Freezing capacity: 9 Kg/24 h
- Fast Freeze Compartment
- Door alarm
- Temperature alarm
- Automatic defrost system in fridge compartment
- Activ0° compartment
- Temperature rise time 16 h
- Ventilation System

Whirlpool fridge freezer: frost free - ART 195/63 A+/NF.1

This Whirlpool fridge freezer features: white color. No frost, frost free technology, that effectively prevents ice build-up in your Freezer, by reducing humidity levels. Glass shelves, providing both robustness and elegance. A fan that provides a smooth and even flow of air in your appliance's cavity, for enhanced ventilation. Unique 6th SENSE FreshControl technology, that automatically adjusts temperature and humidity levels inside your appliance, ensuring long-lasting freshness.



Fresh Control

Fresher, for longer. The unique 6TH SENSE Fresh Control technology dynamically adjusts the humidity levels and temperature inside your freezer, to ensure long-lasting freshness (up to 4 times longer).



Active 0°

Perfect for your fresh meat and fish. Activ0° technology ensures an ideal storage environment for your fresh meat and fish, by maintaining constant temperature levels and protecting the taste, texture and nutritional properties of your food.



Temperature alarm

Designed for your peace of mind. The Temperature alarm feature warns you if there is an increase in temperature inside your fridge, helping you to avoid potential food spoilage.



Space Management

All the space you need. This Whirlpool Fridge Freezer's innovative design provides all the space and flexibility you need to comfortably and easily store your food and drink.



Ventilation

This Whirlpool Fridge Freezer features a fan that provides a smooth and even flow of air in your appliance's cavity, for enhanced ventilation.



Energy class A+

Outstanding energy efficiency. With its A+ energy rating, this Whirlpool appliance will allow you to enjoy both ideal performance and excellent energy consumption.



Glass shelves

A passion for beauty in every detail. This Whirlpool Refrigerator includes glass shelves designed to combine beauty and functionality, and providing you the most fulfilling user experience imaginable.



Fresh Box

Creates ideal conditions to store fruit and vegetables. A drawer to store your fruits and vegetables.

ART 195/63 A+/NF.1

12NC: 859991556840

GTIN (EAN) code: 8003437042898

Whirlpool

SENSING THE DIFFERENCE

MAIN FEATURES

Product group	Fridge/freezer combination
Installation type	Built-in
Type of control	Electronic
Construction type	built-in
Main colour of product	White
Electrical connection rating (W)	160
Current (A)	13
Voltage (V)	220-240
Frequency (Hz)	50
Number of compressors	1
Length of Electrical Supply Cord (cm)	200
Plug type	UK
Total unit net capacity (l)	258
Star Rating	4
Height of the product	1770
Width of the product	540
Depth of the product	545
Maximum adjustability feet	0
Net weight (kg)	59.2

TECHNICAL FEATURES

Defrost process fridge section	Automatic
Defrost process freezer section	Frost-free
Fast cooling possibility	No
Fast freezing function	Yes
Door opened indicator freezer	Yes
Temperature adjustable	N/A
Temperature adjustable freezer	Yes
Interior ventilator fridge section	Yes
Number of freezing drawers	3
Automatic motor-driven ice-maker	No
Number of shelves in fridge compartment	5
Material of the shelves	Glass
Thermometer fridge section	None
Thermometer freezer section	None
Number of temperature zones	1

PERFORMANCES

Energy efficiency class - NEW (2010/30/EU)	A+
Energy consumption annual (kWh/annum) - NEW (2010/30/EU)	294
Refrigerator Net capacity (l) - NEW (2010/30/EU)	195
Freezer Net capacity (l) - NEW (2010/30/EU)	63
Freezing capacity (kg/24h) - NEW (2010/30/EU)	9
Climate class	SN-T
Noise level (dB(A) re 1 pW)	38
Frost free system	Freezer

