

AMW 735 IX

12NC: 858773501900

EAN code: 8003437389962

Whirlpool

SENSING THE DIFFERENCE

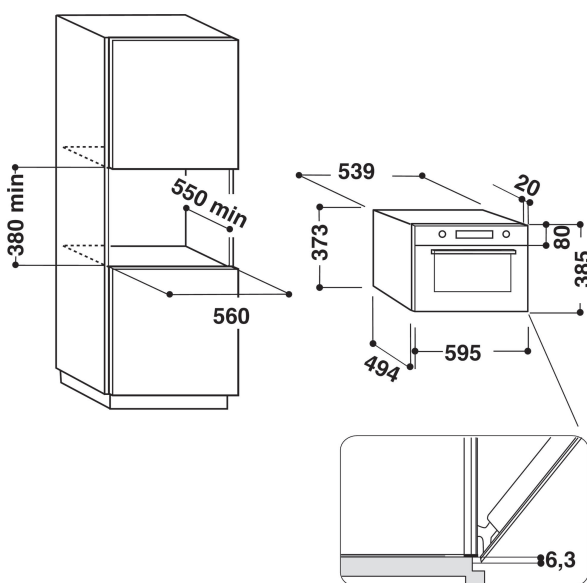

MAIN FEATURES

Product group	Microwave
Commercial code	AMW 735 IX
Main colour of product	Stainless steel
Type of micro-wave oven	MW+Grill function
Construction type	Вбудована
Type of control	Electronic
Type of control setting and signalling devices	LCD
Additional cooking method Grill	Yes
Crisp	Yes
Steam	Hi
Additional cooking method Fan cooking	Hi
Clock	Yes
Automatic programmes	Yes
Height of the product	385
Width of the product	595
Depth of the product	468
Minimum niche height	380
Minimum niche width	556
Niche depth	550
Net weight (kg)	26.80
Cavity capacity (l)	31
Turntable	Yes
Turntable diameter (mm)	325
Integrated Cleaning system	Hi

TECHNICAL FEATURES

Current (A)	10
Voltage (V)	230
Frequency (Hz)	50
Length of Electrical Supply Cord (cm)	135
Plug type	Hi
Timer	Minute minder
Grill power (W)	800
Type of grill	Quartz
Cavity material	Stainless steel
Interior light	Yes
Additional cooking method Grill	Yes
Position of interior lights	Right side

ENERGY LABEL

6th Sense / Dynamic Intelligence	Hi
Number of power levels	7
Maximum micro-wave power (W)	1000
Bread defrost	Hi
Jet defrost	Yes
Jet start	Yes