

DSIO 3T224 Z E

12NC: F155312

GTIN (EAN) code: 8050147553121

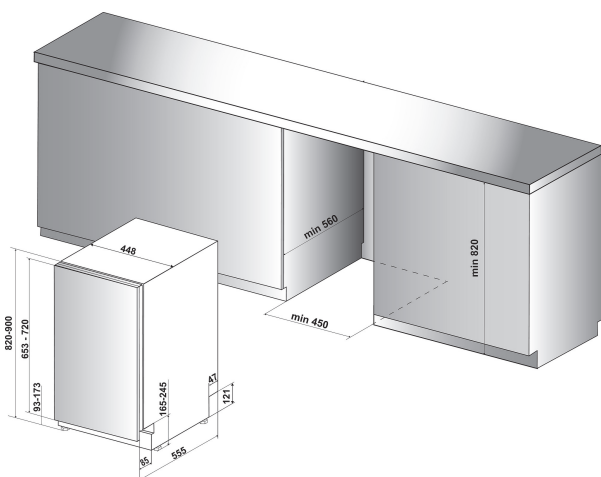

MAIN FEATURES

Construction type	Built-in
Installation type	Plne vestavná
Type of control	Electronic
Type of control settings	-
Removable work top	N/A
Door decor panel	N/A
Main colour of product	Stříbrná
Electrical connection rating (W)	1900
Current (A)	10
Voltage (V)	220-240
Frequency (Hz)	50
Length of Electrical Supply Cord (cm)	130
Plug type	Schuko
Length inlet hose (cm)	155
Ledningslængde (cm)	150
Adjustable plinth	Ne
Height of removable worktop (mm)	0
Adjustable feet	Yes - all from front
Height of the product	820
Width of the product	448
Depth of the product	555
Depth with open door 90 degree (mm)	-
Minimum niche height	820
Maximum niche height	900
Minimum niche width	450
Maximum niche width	600
Niche depth	560
Net weight (kg)	29.6
Gross weight (kg)	31.6

TECHNICAL FEATURES

Automatic programmes	Ano
Maximum temperature for water intake (°C)	60
Start delay options	Continuous
Start delay time max. (h)	12
Progress indicator	-
Digital countdown indicator	Ano
Salt light indicator	Ano
Rinse aid light indicator	Ano
Safety device	Ano
Adjustable upper basket	Ano
Largest loadable dish upper basket (cm)	0
Largest loadable dish lower basket (cm)	0
Number of place settings	10

ENERGETICKÝ ŠTÍTEK

Energy efficiency class - NEW (2010/30/EU)	A++
Energy consumption annual (kWh/annum) - NEW (2010/30/EU)	212
Duration of the left-on mode - NEW (2010/30/EU)	12
Power consumption in left-on mode - NEW (2010/30/EU)	5
Power consumption in off-mode - NEW (2010/30/EU)	0.5
Water consumption annual (l/annum) - NEW (2010/30/EU)	2520
Noise level (dB(A) re 1 pW)	44