

# AKZM 7540/WH

12NC: 852575401110

EAN code: 8003437830112

**Whirlpool**

SENSING THE DIFFERENCE

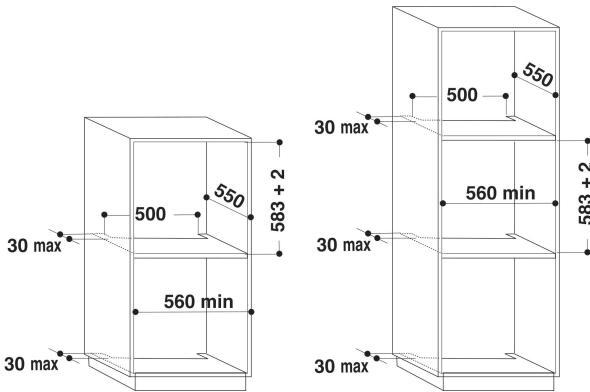

## MAIN FEATURES

|  |                           |
|--|---------------------------|
| Product group                                  | Oven                      |
| Commercial code                                | AKZM 7540/WH              |
| Main colour of product                         | White                     |
| Construction type                              | Вбудована                 |
| Type of control                                | Mechanical and electronic |
| Type of control setting and signalling devices | -                         |
| Are any hobs controls integrated?              | Hi                        |
| Which kind of hobs can be controlled?          | -                         |
| Automatic programmes                           | Yes                       |
| Current (A)                                    | 16                        |
| Voltage (V)                                    | 220-240                   |
| Frequency (Hz)                                 | 50-60                     |
| Length of Electrical Supply Cord (cm)          | 90                        |
| Plug type                                      | Hi                        |
| Depth with open door 90 degree (mm)            | -                         |
| Height of the product                          | 595                       |
| Width of the product                           | 595                       |
| Depth of the product                           | 564                       |
| Minimum niche height                           | 0                         |
| Minimum niche width                            | 0                         |
| Niche depth                                    | 0                         |
| Net weight (kg)                                | 35.50                     |
| Usable volume (of cavity)                      | 73                        |
| Noise level (dB(A) re 1 pW)                    | 0                         |
| Integrated Cleaning system                     | Catalytic all sides       |
| Grids  | 1                         |
| Trays  | 2                         |

## TECHNICAL FEATURES

|                             |                |
|-----------------------------|----------------|
| Timer                       | Programmable   |
| Time control                | Electronic     |
| Time-setting options        | Start and Stop |
| Safety device               | -              |
| Interior light              | Yes            |
| Number of interior lights   | 1              |
| Position of interior lights | Rear           |
| Oven guides                 | Telescopic     |
| Probe                       | Hi             |

## ENERGY LABEL

|  |             |
|--|-------------|
| Energy input                                   | Electric    |
| Type of energy                                 | Electricity |
| Energy efficiency class - cavity 1             | A           |
| Energy consumption conventional (kWh)          | 0.91        |
| Energy consumption forced air convection (kWh) | 0.70        |