

ACM 813/BA

12NC: 859991011220

GTIN (EAN) code: 8003437827990

Whirlpool

SENSING THE DIFFERENCE

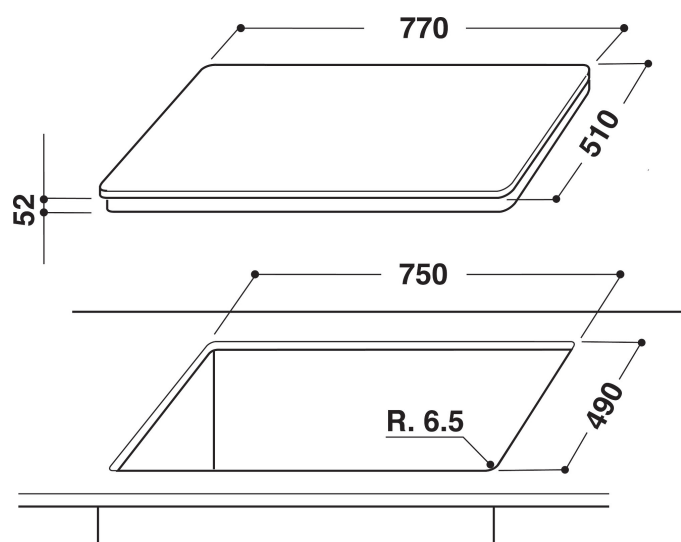
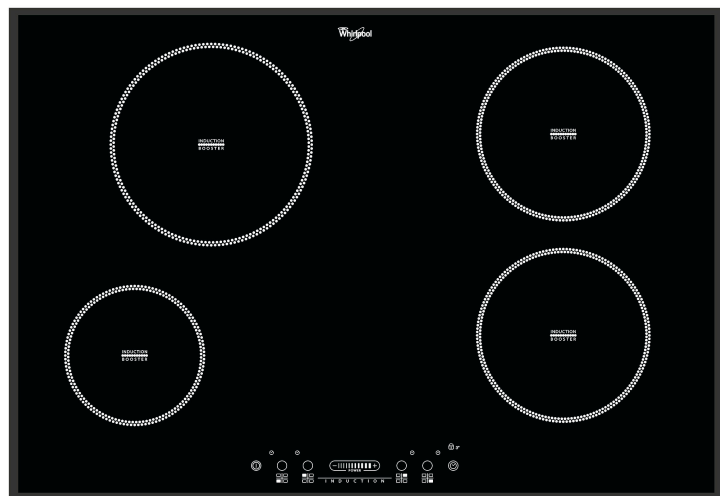

- 4 induction cooking zones
- Residual heat indicator
- Child lock
- On/Off Switch
- 77 cm hob
- Timer
- Slider touch control
- Black Glass Hob
- 4 Boosters
- 4 Plate on Indicator
- Total power declared: 7.2 kW
- Power on indicator
- Supply cord included
- Power manager: maximum power setting 2,5 kW/4 kW/6 kW/7,4 kW
- 4 sides bevelled
- Dimensions HxWxD: 52x770x510 mm

Whirlpool induction glass-ceramic hob - ACM 813/BA

4 induction rings. intuitive slider, for effortless control of your appliance settings. This Whirlpool induction glass-ceramic Hob features: An elegant technology, that heats the pan, not the hob, reducing energy dispersion and providing perfect cooking results. Electric power supply.



Slider

Intuitive cooking. The intuitive touch-sensitive Slider allows you to control the power for each hob whilst the illuminated display shows you which cooking zones are currently being used.



Power management

Outstanding energy efficiency. With the Power Management function, you set the hob's power level, to avoid the risk of overloading the power supply in your home.



Booster

Enjoy super fast boiling times with the Booster cooking zone.



Front Controls

Complete control over your cooking. Easily accessible and genuinely intuitive, the controls are conveniently positioned on the front panel of your hob, providing a frictionless cooking experience.



Induction technology

Faster, energy-efficient cooking. Induction technology heats the pan, not the hob, reducing energy dispersion by 10%, and providing perfect cooking results.

ACM 813/BA

12NC: 859991011220

GTIN (EAN) code: 8003437827990

Whirlpool

SENSING THE DIFFERENCE

MAIN FEATURES

Product group	Hob
Construction type	Built-in
Type of control	Electronic
Type of control settings	-
Number of gas burners	0
Number of electric cooking zones	4
Number of electric plates	0
Number of radiant plates	0
Number of halogen plates	0
Number of induction plates	4
Number of electric warming zones	0
Location of control panel	Front
Basic surface material	Glass
Main colour of product	Black
Electrical connection rating (W)	7200
Gas connection rating (W)	0
Current (A)	31,3
Voltage (V)	230
Frequency (Hz)	50/60
Length of Electrical Supply Cord (cm)	120
Plug type	No
Gas connection	N/A
Width of the product	770
Height of the product	52
Depth of the product	510
Minimum niche height	30
Minimum niche width	750
Niche depth	490
Net weight (kg)	15
Automatic programmes	No

TECHNICAL FEATURES

Power on indicator	Yes
Number of indicators	4
Type of regulation	Stepless energy regulated
Type of lid	Without
Residual heat indicator	Separate
Main on/off switch	Yes
Safety device	-
Timer	Yes

PERFORMANCES

Energy input	Electric
--------------	----------