

Hotpoint

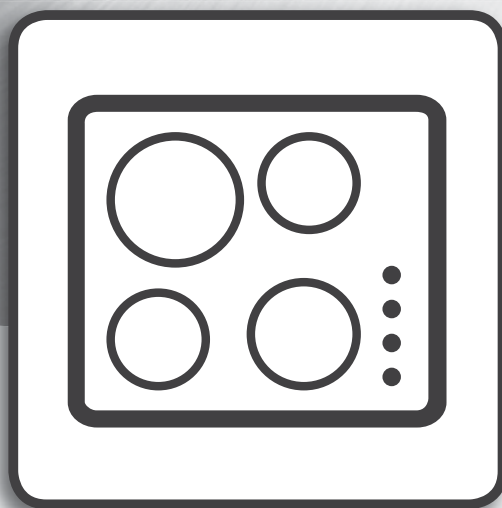

User Manual



www.hotpoint.eu/register



USER MANUAL



THANK YOU FOR BUYING A WHIRLPOOL PRODUCT.

In order to receive a more complete assistance, please register your product on www.hotpoint.eu/register.

INDEX

HEALTH & SAFETY GUIDE.....	3
Safety instructions.....	3
USE & CARE GUIDE	5
Product description.....	5
Control panel	5
Accessories	6
How to use the appliance.....	6
First time use	6
Daily use.....	6
Special functions.....	8
Indicators.....	10
Cooking table.....	10
Maintenance and cleaning.....	10
Troubleshooting.....	11
Sounds produced during operation	11
Verified cooking	11
After-sales service	12
INSTALLATION GUIDE.....	13

SAFETY INSTRUCTIONS

IMPORTANT TO BE READ AND OBSERVED

Before using the appliance, read these safety instructions. Keep them nearby for future reference.

These instructions and the appliance itself provide important safety warnings to be observed at all times. The manufacturer declines any liability for failure to observe these safety instructions, for inappropriate use of the appliance or incorrect setting of controls.

⚠ **WARNING:** If the hob surface is cracked, do not use the appliance - risk of electric shock.

⚠ **WARNING:** Danger of fire: Do not store items on the cooking surfaces.

⚠ **CAUTION:** The cooking process has to be supervised. A short cooking process has to be supervised continuously.

⚠ **WARNING:** Unattended cooking on a hob with fat or oil can be dangerous - risk of fire. NEVER try to extinguish a fire with water: instead, switch off the appliance and then cover flame e.g. with a lid or a fire blanket.

⚠ Do not use the hob as a work surface or support. Keep clothes or other flammable materials away from the appliance, until all the components have cooled down completely - risk of fire.

⚠ Metallic objects such as knives, forks, spoons and lids should not be placed on the hob surface since they can get hot.

⚠ Very young children (0-3 years) should be kept away from the appliance. Young children (3-8 years) should be kept away from the appliance unless continuously supervised. Children from 8 years old and above and persons with reduced physical, sensory or mental capabilities or lack of experience and knowledge can use this appliance only if they are supervised or have been given instructions on safe use and understand the hazards involved. Children must not play with the appliance. Cleaning and user maintenance must not be carried out by children without supervision.

⚠ After use, switch off the hob element by its control and do not rely on the pan detector.

⚠ **WARNING:** The appliance and its accessible parts become hot during use. Care should be taken to avoid touching heating elements. Children less than 8 years of age shall be kept away unless continuously supervised.

PERMITTED USE

⚠ **CAUTION:** the appliance is not intended to be operated by means of an external switching device, such as a timer, or separate remote controlled system.

⚠ This appliance is intended to be used in household and similar applications such as: staff kitchen areas in shops, offices and other working environments; farm houses; by clients in hotels, motels, bed & breakfast and other residential environments.

⚠ No other use is permitted (e.g. heating rooms).

⚠ This appliance is not for professional use. Do not use the appliance outdoors.

INSTALLATION

⚠ The appliance must be handled and installed by two or more persons - risk of injury. Use protective gloves to unpack and install - risk of cuts.

⚠ Installation, including water supply (if any), electrical connections and repairs must be carried out by a qualified technician. Do not repair or replace any part of the appliance unless specifically stated in the user manual. Keep children away from the installation site. After unpacking the appliance, make sure that it has not been damaged during transport. In the event of problems, contact the dealer or your nearest After-sales Service. Once installed, packaging waste (plastic, styrofoam parts etc.) must be stored out of reach of children - risk of suffocation. The appliance must be disconnected from the power supply before any installation operation - risk of electric shock. During installation, make sure the appliance does not damage the power cable - risk of fire or electric shock. Only activate the appliance when the installation has been completed.

⚠ Carry out all cabinet cutting operations before fitting the appliance and remove all wood chips and sawdust.

⚠ If the appliance is not installed above an oven, a separator panel (not included) must be installed in the compartment under the appliance.

ELECTRICAL WARNINGS

⚠ It must be possible to disconnect the appliance from the power supply by unplugging it if plug is accessible, or by a multi-pole switch installed upstream of the socket in accordance with the wiring rules and the appliance must be earthed in conformity with national electrical safety standards.

⚠ Do not use extension leads, multiple sockets or adapters. The electrical components must not be accessible to the user after installation. Do not use the appliance when you are wet or barefoot. Do not operate this appliance if it has a damaged power cable or plug, if it is not working properly, or if it has been damaged or dropped.

⚠ Installation using a power cable plug is not allowed unless the product is already equipped with the one provided by the Manufacturer.

⚠ If the supply cord is damaged, it must be replaced with an identical one by the manufacturer, its service agent or similarly qualified persons in order to avoid a hazard - risk of electric shock.

CLEANING AND MAINTENANCE

⚠ WARNING: Ensure that the appliance is switched off and disconnected from the power supply before performing any maintenance operation; never use steam cleaning equipment - risk of electric shock.

⚠ Do not use abrasive or corrosive products, chlorine-based cleaners or pan scourers.

DISPOSAL OF PACKAGING MATERIALS

The packaging material is 100% recyclable and is marked with the recycle symbol .

The various parts of the packaging must therefore be disposed of responsibly and in full compliance with local authority regulations governing waste disposal.

DISPOSAL OF HOUSEHOLD APPLIANCES

This appliance is manufactured with recyclable or reusable materials. Dispose of it in accordance with local waste disposal regulations. For further information on the treatment, recovery and recycling of household electrical appliances, contact your local authority, the collection service for household waste or the store where you purchased the appliance. This appliance is marked in compliance with European Directive 2012/19/EU, Waste Electrical and Electronic Equipment (WEEE) and with the Waste Electrical and Electronic Equipment regulations 2013 (as amended).

By ensuring this product is disposed of correctly, you will help prevent negative consequences for the environment and human health.

The symbol  on the product or on the accompanying documentation indicates that it should not be treated as domestic waste but must be taken to an appropriate collection center for the recycling of electrical and electronic equipment.

ENERGY SAVING TIPS

Make the most of your hot plate's residual heat by switching it off a few minutes before you finish cooking.

The base of your pot or pan should cover the hot plate completely; a container that is smaller than the hot plate will cause energy to be wasted.

Cover your pots and pans with tight-fitting lids while cooking and use as little water as possible. Cooking with the lid off will greatly increase energy consumption.

Use only flat-bottomed pots and pans.

DECLARATION OF CONFORMITY

This appliance meets Ecodesign requirements of European Regulation 66/2014 and The Ecodesign for Energy-Related Products and Energy Information (Amendment) (EU Exit) Regulations 2019 in compliance with the European standard EN 60350-2.

NOTE

People with a pacemaker or similar medical device should use care when standing near this induction cooktop while it is on. The electromagnetic field may affect the pacemaker or similar device. Consult your doctor, or the manufacturer of the pacemaker or similar medical device for additional information about its effects with electromagnetic fields of the induction cooktop.

PRODUCT DESCRIPTION

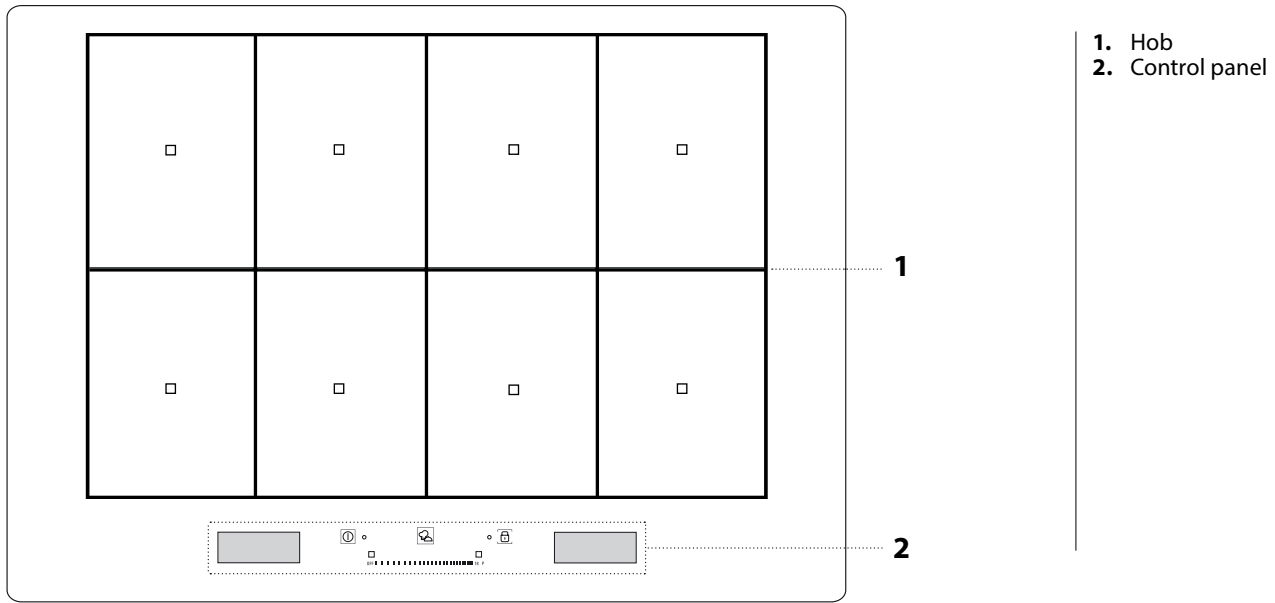

CONTROL PANEL

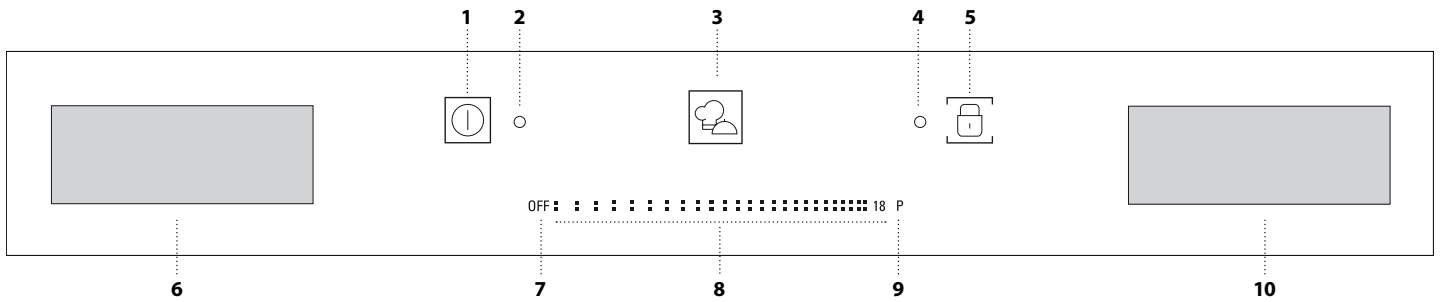

- 1. On/ off button
- 2. Indicator light - hob switched on
- 3. "Active cook " button (special functions)

- 4. Indicator light - key lock active
- 5. Key lock
- 6. Cooking zone selection display
- 7. Cooking zone off button

- 8. Slide touchscreen
- 9. Quick heat button
- 10. "Manage functions" display

ACCESSORIES

POTS AND PANS

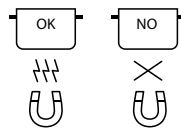

Only use pots and pans made from ferromagnetic material which are suitable for use with induction hobs. To determine whether a pot is suitable, check for the  symbol (usually stamped on the bottom). A magnet may be used to check whether

pots are magnetic.

The quality and the structure of the pot base can alter cooking performance. Some indications for the diameter of the base do not correspond to the actual diameter of the ferromagnetic surface.

EMPTY POTS OR POTS WITH A THIN BASE

Do not use empty pots or pans when the hob is on.

The hob is equipped with an internal safety system that constantly monitors the temperature, activating the "automatic off" function where high temperatures are detected. When used with empty pots or pots with thin bases, the temperature may rise very quickly, and the "automatic off" function may be triggered with a slight delay, damaging

the pot or pan. If this occurs, do not touch anything, and wait for all components to cool down.

If any error messages appear, call the service centre.

MINIMUM DIAMETER OF POT/PAN BASE FOR THE DIFFERENT COOKING AREAS

To ensure that the hob functions properly, the pot must cover one or more of the reference points indicated on the surface of the hob, and must be of a suitable minimum diameter.

Positioning of accessory	Minimum diameter
centred on 1 point	10 cm
2 points covered	19 cm
3 points covered	fish kettle/wire rack
4 points covered (horizontal)	fish kettle/wire rack
4 points (2 + 2) covered (vertical)	26 cm

HOW TO USE THE APPLIANCE

FIRST TIME USE

The hob settings can be changed at any time. To change the settings, click on the  symbol that appears on the manage functions display.

From the settings menu, you can:

- select the language;
- adjust the brightness;
- adjust the volume of the sound alerts;
- adjust the button tones;
- adjust the power of the hob;
- restore the factory settings of the hob;
- check the software version installed.

If a power failure occurs, the settings are maintained.

ADJUSTING THE POWER OF THE HOB

The maximum power level of the hob can be set from the settings menu, in accordance with requirements, or with the timer duration.

The power levels available are: 2.5kW – 4.0kW – 6.0kW – 7.4kW.

DAILY USE



SWITCHING THE HOB ON/OFF

To switch the hob on, press the on button for approx. 1 second until the displays light up.

The hob will be automatically deactivated after 30 seconds if you do not select a function within this time.

The hob turns off if you press any button for more than 10 seconds.

To switch off, press the same button until the displays switch off. All the cooking zones are deactivated.

If the hob has been in use, when you switch it off, all cooking zones will be deactivated, and the residual heat indicator "H" will remain lit until the cooking zones have cooled down.

SELECTING THE COOKING ZONE

The desired cooking zone can be selected from the left-hand display, by pressing the corresponding pane. On all the not selected zones a lightly stripe will appear.

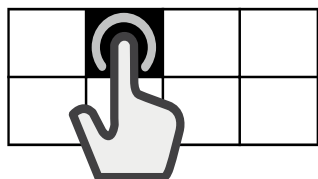

SELECTING THE FLEXIBLE AREA

The flexible area is the area in which several of the cooking zones overlap, and can be used as a single cooking zone.

To create a flexible area:

Select multiple panes or slide your finger across, gradually joining the panes together.

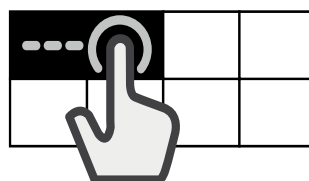

To divide a flexible area:

Press and hold the pane corresponding to the zone that you want to separate for 3 seconds. Alternatively, press the "divide zone" button  that appears in the manage functions display.

When the cooking zone is divided, the same level of power is set for each of the separate zones.

If all the selected cooking zones are not covered by the pot in 30 seconds, a dense striped will appear on the left-hand display. It's possible to reactivate that area with the "place a pot" command using the right-hand display.



ACTIVATING/DEACTIVATING COOKING ZONES AND ADJUSTING POWER

To activate the cooking zones:

1. Switch on the hob. If a recipient is already in place, the hob automatically detects it. Select the suggested zone to choose the power.
2. Place the pot in the chosen cooking zone, ensuring that it is covering one or more of the reference points on the surface of the hob.

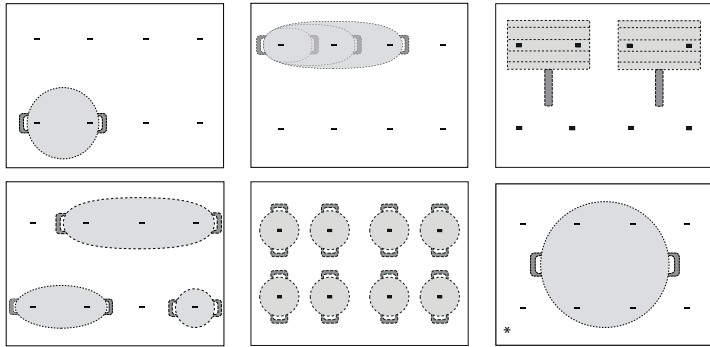

* Using this position will allow you to benefit from maximum power output.

Please note: Do not cover the display or the slide touchscreen with accessories. If a utensil is covering one of the displays, the hob may not function properly. On the right display, the message «CHECK TOUCH AREA, remove the object within one minute» will appear. Remove the object and wait until the message disappears. If the problem persists, disconnect and reconnect the power to the cooktop.

In the cooking zones close to the control panel, it is advisable to keep pots and pans inside the markings (taking both the bottom of the pan and the upper edge into consideration, as this tends to be larger). This prevents excessive overheating of the touchpad. When grilling or frying, please use the rear cooking zones wherever possible.

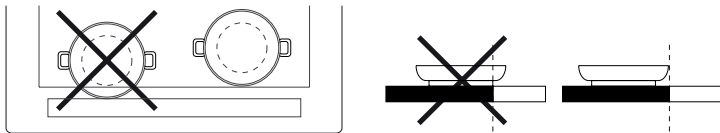

3. Select the cooking zone or flexible area from the left-hand display.
4. Set the desired power level by pressing or moving your finger horizontally across the slide touchscreen.



The power level set will appear in the pane of the cooking zone selected.

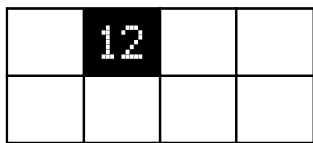

Each cooking zone offers a range of different heat settings, from "1" (minimum power) to "18" (maximum power).

Using the slide touchscreen, you can also select the quick heat function, which will appear on the display with the letter "P".

Please note: If the pot is not suitable for induction cooking, is not positioned correctly or is not of an appropriate size, the cooking zone pane will flash. If no pot is detected within 30 seconds of making the selection, the cooking zone switches off.

To deactivate the cooking zones:

Select the cooking zone in the left-hand display and press the "OFF" button at the top of the slide touchscreen. If the cooking zone is still hot, the residual heat indicator "H" will appear in the corresponding pane.

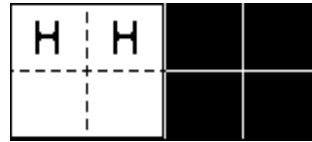

PLACE A POT

When using a cooking area composed of several zones, the pot can be placed anywhere on the active area. The hob will automatically recognise the actual positioning of the pot.

If you wish to add an additional pot to the active cooking area, use the "Place a pot" command to allow the hob to detect the new pot.

KEY LOCK

To prevent accidental activation of the hob during cleaning, or to prevent the controls from being changed accidentally whilst cooking, press the "Key lock" button for 3 seconds: a beep and a warning light indicate that this function has been activated.

The control panel will be locked, with the exception of the off button.

To reactivate the controls, press the "Key Lock" button again for 3 seconds. The warning light switches off and the hob is active again.

TIMER

When the hob is off, you can use the right-hand display as a timer.

To activate the timer:

1. Switch on the hob.
2. Press the hourglass icon that appears on the manage functions display.
3. Use the +/- buttons to set the time.
4. When the set time has elapsed, an acoustic signal sounds.

To change or deactivate the timer:

1. Press the hourglass icon that appears on the manage functions display.
2. Use the + and - buttons to reset the desired time, or press the "STOP" button to turn off the timer.

SETTING THE COOKING TIME

The cooking zones can be programmed to switch off automatically.

To set the cooking time:

1. Select the cooking zone and set the required power level.
2. Press the stopwatch icon that appears on the manage functions display.
3. Use the +/- buttons to set the time.
4. Once the set time has elapsed, an acoustic signal sounds and the cooking zone switches off automatically.

To change or deactivate the cooking timer:

1. Select the active cooking zone.
2. Press the stopwatch icon that appears on the manage functions display.
3. Use the + and - buttons to reset the desired time, or press the "STOP" button to cancel the set cooking time.

A cooking time can be set for each zone or flexible area by following the same steps.

SPECIAL FUNCTIONS



ACTIVE COOK

The Active cook button allows users to access a number of special features:

- My menu
- Active heat
- Total flexi

In the right-hand manage functions display, you can navigate between the special functions and select the option you want.

With the arrows, \wedge \vee you can scroll through the available options.

Use the button OK to confirm your choice, and the double arrow \ll to return to the previous menu.

MY MENU

This function allows you to select one of the pre-set functions which help you to cook a range of different types of food in the best possible manner.

The hob assists the user by providing ideal conditions for heating and seasoning the pot. It also provides instructions to be followed during the different stages of cooking, in order to achieve optimum results.

To activate the My menu function:

1. Press the "Active cook" button.
2. Select "My menu" from the manage functions display and confirm.



3. Select the *category of food* that you plan to cook and confirm.



4. Select the *cooking method* and confirm.

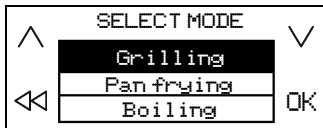

5. Select the *cooking conditions* and confirm.



6. Four cooking zones will now be available. Place the pot in position, ensuring that it is covering at least two of the reference points on the surface of the hob.

The "Moka" cooking mode is the only one which allows just one reference point to be covered.

Below is an example of positioning for a number of accessories.

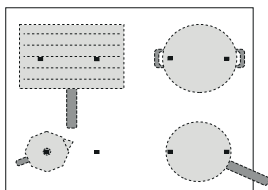

7. Select the desired cooking zone from the left-hand display. An "A" will appear in the selected zone.

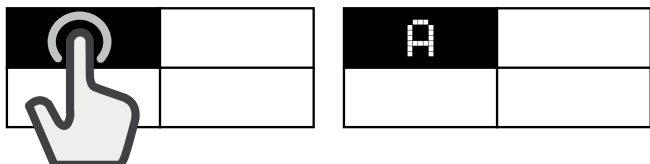

8. In the right-hand display, the instructions to follow will appear (e.g. "Add Oil" or "Add food"). At the end of each stage, the user must confirm in order to proceed with cooking.
9. If necessary, the pre-set power level can be changed at any time, using the + and - buttons.
10. When cooking is complete, press the "STOP" button to turn off the cooking zone. If multiple zones have been used during cooking, you must first select the cooking zone you want to switch off.

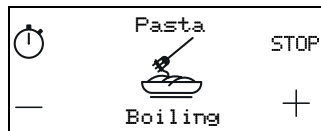

Please note: The "My menu" function can be activated even when one or more cooking zones are already active.

To activate the My menu function for more than one cooking zone:

After activating the "My menu" function for the first cooking zone, press the Active cook button again, and repeat the activation process for a new cooking zone. Zones that are already active cannot be selected.

Please note: You can use up to 4 zones with the "My menu" function, provided that the power level setting selected allows for this. The zones cannot be combined to form a larger area.

To cook traditionally when the My menu function is active:

When the "My menu" function is active, you can select the cooking zone that you wish to activate from the left-hand display, and set the power level for this zone, before proceeding with using this in the normal way.

Selectable options

FOOD CATEGORY		COOKING METHOD
	Meat	Grilling, Pan frying, Boiling
	Fish	Grilling, Pan frying, Boiling
	Vegetables	Grilling, Pan frying, Boiling
	Sauces and soups	Sauces (Tomato, Béchamel) Soups (Searing, Simmering, Creamy soups)
	Dessert	Custard, Panna cotta, Melted chocolate, Pancake, Rice pudding
	Eggs	Fried eggs, Omelette, Boiling (Boiled eggs, Soft-boiled), Frittata, Scrambled
	Cheese	Grilling, Pan frying, Fondue
	Pasta	Boiling, Pan frying, Risotto, Rice pudding
	Beverage	Milk, Water, Moka
	Custom	Boiling, Grilling, Pan frying, Simmering, Melting

MAIN COOKING METHODS

(Each method may include additional options)

MELTING

To bring food to the ideal temperature for melting and to maintain the condition of the food without risk of burning. This method does not damage delicate foods such as chocolate, and prevents them from sticking to the pot. The rate of cooking can be adjusted at any time using the "+" and "-" buttons on the right-hand display.

SIMMERING

For slow-cook dishes and for slowly evaporating liquid, maintaining the condition of the food without risk of burning. This method does not damage food, and prevents it from sticking to the pot. The quality and type of pot can affect performance or cooking times.

The rate of cooking can be adjusted at any time using the "+" and "-" buttons on the right-hand display.



BOILING*

To efficiently heat water and alert the user when it begins to boil, via an audible and visual signal.

While awaiting confirmation from the user, the system keeps the water at a controlled simmer, preventing spills and wasted energy. Whilst this function is active, an audible alarm warns the user if the pot is empty (no water) or if it has boiled dry.

Only add salt after the boiling alert has sounded.



PAN FRYING*

To preheat or season an empty pot or pan. An audible and visual signal indicates that the ideal temperature has been reached for food to be added to the pot or pan. While awaiting confirmation from the user, the system keeps the accessory at a controlled heat, preventing the pan from reaching damaging temperatures and avoiding energy wastage.

For optimum conditions, use this function with pots and seasoning at room temperature.

Dedicated accessories must be used for this function.

Do not use the lid - to protect against splashes, a splash guard is recommended. It is advisable to use oils that are suitable for frying when cooking with this function, such as seed oils of various types. When using different oils, always take extra care to supervise cooking during first use.



GRILLING*

This function allows for optimum grilling of a range of foods, according to their thickness. When the ideal temperature has been reached for food to be added, the hob beeps. The hob then stabilises the temperature throughout cooking, keeping it constant. Once the user has confirmed that food has been added, cooking begins.

It is advisable to prepare the food during the heating stage, adding it as soon as you hear the beep.

For optimum conditions, use this function with pots and seasoning at room temperature.

If you are not using the wire rack designed for this purpose, take extra care when first using the grill function, as the quality of the base may affect heating times. Accessories with very thin bases can reach very high temperatures in a short time.



MOKA*

This function allows "moka" stove-top coffee makers to be heated automatically. The heating cycle can be activated by selecting the function in the menu, and a beep will sound when the coffee is ready. The function is programmed to switch off automatically, preventing spills. When using for the first time, always check that the conditions described are met. For optimum conditions, use this function with the coffee maker and water at room temperature.

***For these functions, the use of dedicated accessories is recommended:**

- for boiling: **WMF SKU: 07.7524.6380**
- for pan frying: **WMF SKU: 05.7528.4021**
- for grilling: **WMF SKU: 05.7650.4291**
- for Moka, Bialetti: **MOKA INDUZIONE 3TZ ANTRACITE**

Please note: Try not to move the pot or pan during the first minute of heating, in order to allow the hob to function optimally.

ACTIVE HEAT

This function divides the hob into four cooking zones, activating these simultaneously at a pre-set power level. It allows you to move pots from one area to another, to allow you to continue cooking at different temperatures.

To activate the Active heat function:

1. Place the pot in position.
2. Press the "Active cook" button.
3. Select "Active heat" from the manage functions display and confirm.



4. The four cooking zone panes appear on the left-hand display, with the corresponding power level (low, medium, high).
5. If you wish to add more pots, use the "Place a pot" command $\square+$.
6. To exit this function, press "STOP".

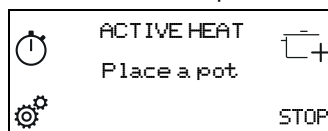

To change the power of a cooking zone:

1. Select cooking zone.
2. Select the desired power level by dragging your finger across the slide touchscreen, which will remain visible for 1 second.
3. The word corresponding to the power level selected (low, medium, high) reappears.

Please note: The changed settings are saved until you change them again or reset them.

TOTAL FLEXI

This function allows you to use the entire hob as a single cooking area.

To activate the Total flexi function:

1. Place the pot in position.
2. Press the "Active cook" button.
3. Select "Total flexi" from the manage functions display and confirm.



4. Set the desired power level from the slide touchscreen. The power level set appears on the left-hand display.
5. If you wish to add more pots, use the "Place a pot" command $\square+$.
6. To exit this function, press "STOP".

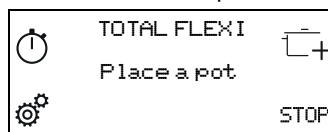

INDICATORS



RESIDUAL HEAT INDICATOR

When the letter "H" appears in one of the cooking zone selection display panes, this means that the corresponding cooking zone is still hot. When the cooking zone has cooled, the "H" disappears.

COOKING TABLE

POWER LEVEL		TYPE OF COOKING	RECOMMENDED USE
Max. heat setting	P	Fast heating	Indicating cooking experience and habits Ideal for rapidly increasing the temperature of food to a fast boil (for water) or for rapidly heating cooking liquids.
	14 - 18	Frying, boiling	Ideal for browning, starting to cook, frying deep-frozen products, bringing liquids to the boil quickly.
		Browning, sautéing, boiling, grilling	Ideal for sautéing, maintaining a lively boil, cooking and grilling.
	10 - 14	Browning, cooking, stewing, sautéing, grilling	Ideal for sautéing, maintaining a gentle boil, cooking and grilling, and preheating accessories.
		Cooking, stewing, sautéing, grilling, cooking until creamy	Ideal for stewing, maintaining a gentle boil, cooking and grilling (for longer periods).
	5 - 9	Cooking, simmering, thickening, creaming	Ideal for slower-cook recipes (rice, sauces, roast, fish) with liquids (e.g. water, wine, broth, milk), and for creaming pasta.
			Ideal for slow-cook recipes (quantities under 1 litre: rice, sauces, roasts, fish) with liquids (e.g. water, wine, broth, milk).
	1 - 4	Melting, thawing	Ideal for softening butter, gently melting chocolate, thawing small items.
		Keeping food warm, creaming risotto	Ideal for keeping small portions of just-cooked food or serving dishes warm and for creaming risotto.
Zero power	Off	-	Hob in stand-by or off mode (possible end-of-cooking residual heat, indicated by an "H").

MAINTENANCE AND CLEANING



WARNING

- Do not use steam cleaning equipment.
- Before cleaning, make sure the cooking zones are switched off and that the residual heat indicator ("H") is not displayed.

Important:

- Do not use abrasive sponges or scouring pads as they may damage the glass.
- After each use, clean the hob (when it is cool) to remove any deposits and stains from food residue.
- Sugar or foods with a high sugar content can damage the hob and must be immediately removed.
- Salt, sugar and sand could scratch the glass surface.
- Use a soft cloth, absorbent kitchen paper or a special hob cleaner (follow the Manufacturer's instructions).
- Spills of liquid in the cooking zones can cause the pots to move or vibrate.
- After cleaning the hob, dry thoroughly.

TROUBLESHOOTING

- Check that the electricity supply has not been shut off.
- If you are unable to turn the hob off after using it, disconnect it from the power supply.
- If alphanumeric codes appear on the display when the hob is switched on, consult the following table for instructions.

Please note: The presence of water, liquid spilled from pots or any objects resting on any of the hob buttons can accidentally activate or deactivate the control panel lock function.

Error code	Description	Possible causes	Cure
C81, C82	The control panel switches off because of excessively high temperatures.	The internal temperature of electronic parts is too high.	Wait for the hob to cool down before using it again.
F02, F04	The connection voltage is wrong.	The sensor detects a discrepancy between the appliance voltage and that of the mains supply.	Disconnect the hob from the mains and check the electrical connection.
F01, F06, F12, F13, F25, F34, F35, F36, F37, F41, F47, F58, F61, F76	Disconnect the hob from the power supply. Wait a few seconds then reconnect the hob to the power supply. If the problem persists, call the service centre and specify the error code that appears on the display.		

SOUNDS PRODUCED DURING OPERATION

Induction hobs may whistle or creak during normal operation. These noises actually come from the cookware and are linked to the characteristics of the pan bottoms (for example, when the bottoms are made from different layers of material or are irregular).

These noises may vary according to the type of cookware used and to the amount of food it contains and are not the symptom of something wrong.

VERIFIED COOKING

A table below has been created specially to make it possible for inspection bodies to use our products.

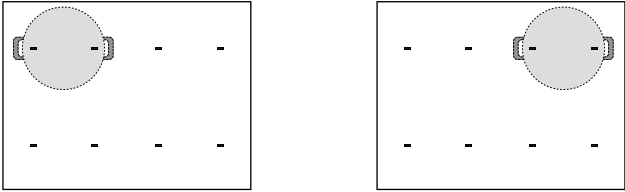
Verified cooking	Verified cooking positions
Heat distribution, "Pancakes" test acc. to EN 60350-2 §7.3	
Heat performance, "French fries" test acc. to EN 60350-2 §7.4	
Melting and keep warm, "chocolate"	
Simmering, "rice pudding"	

ECO-DESIGN: The test was carried out in accordance with regulations, by selecting all of the cooking zones on the hob to form a single area, or by using the Flexifull function.

AFTER-SALES SERVICE

BEFORE CALLING THE AFTER-SALES SERVICE:

1. See if you can solve the problem by yourself with the help of the suggestions given in the **TROUBLESHOOTING**.
2. Switch the appliance off and back on again to see if the fault persists.

IF AFTER THE ABOVE CHECKS THE FAULT STILL OCCURS, GET IN TOUCH WITH THE NEAREST AFTER-SALES SERVICE.

To receive assistance, call the number shown on the warranty booklet or follow the instructions on the website **www.hotpoint.eu**.

When contacting our Client After sales service, always specify:

- a brief description of the fault;
- the type and exact model of the appliance;

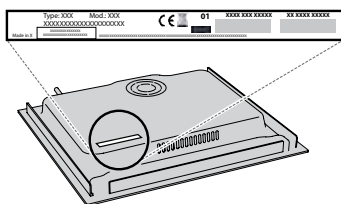

- the serial number (number after the word SN on the rating plate located under the appliance). The serial number is also indicated in the documentation;



Mod. **XXX XXX**

Ind.C. **XXXX XXXX XXXX**

Prod.N. **86999XXXXXXX** S.N. **XXXX XXXX XXXX**

- your full address;
- your telephone number.

If any repairs are required, please contact an authorized after-sales service (to guarantee that original spare parts will be used and repairs carried out correctly).

In the case of flush-mounted installation, call the After Sales Service to request assembly of screws kit 4801 211 00112.

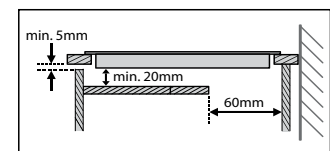
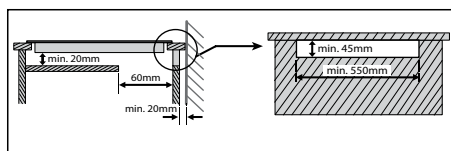
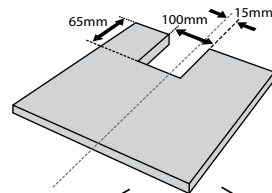
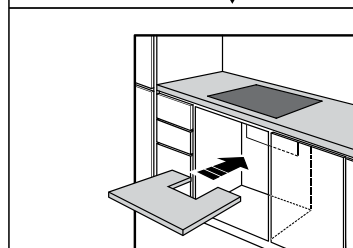
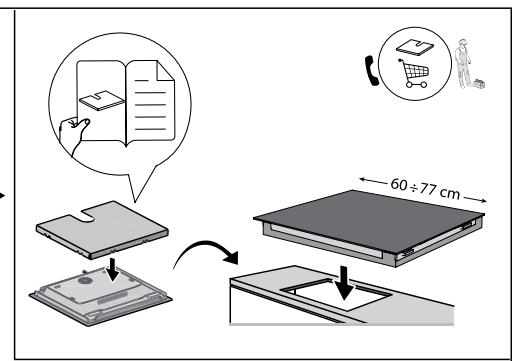
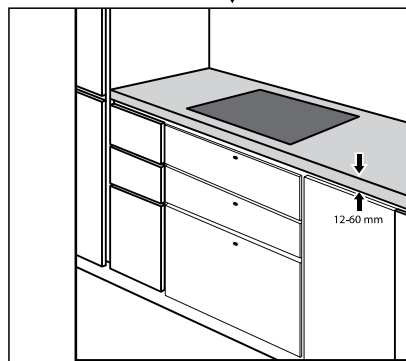
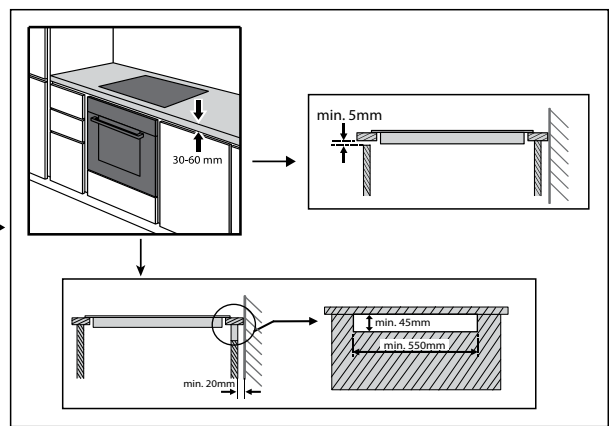
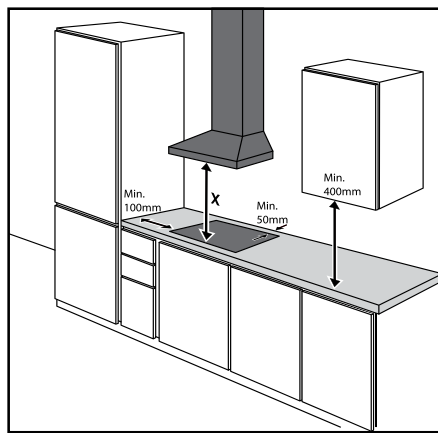
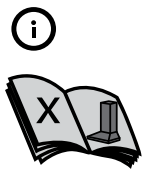
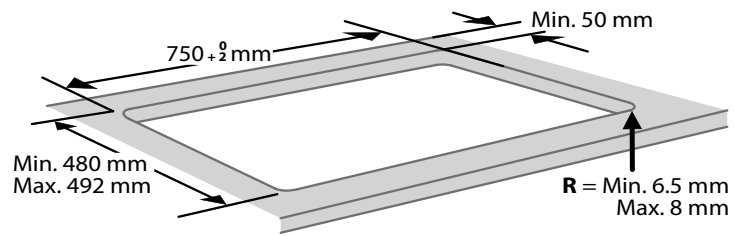
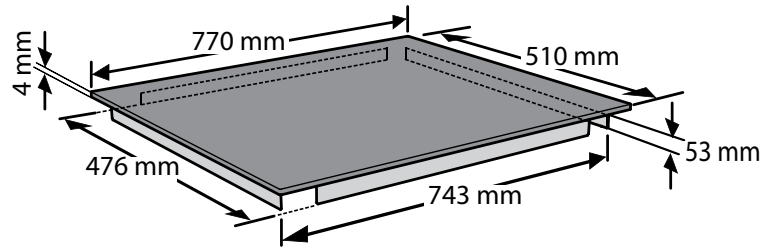

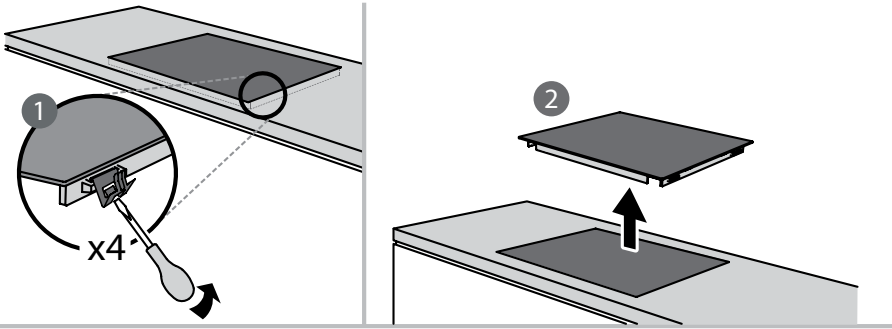
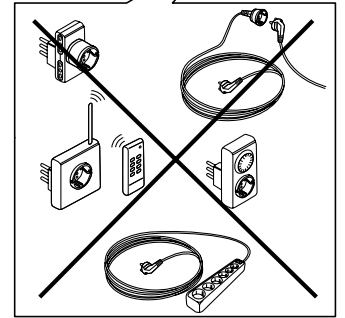
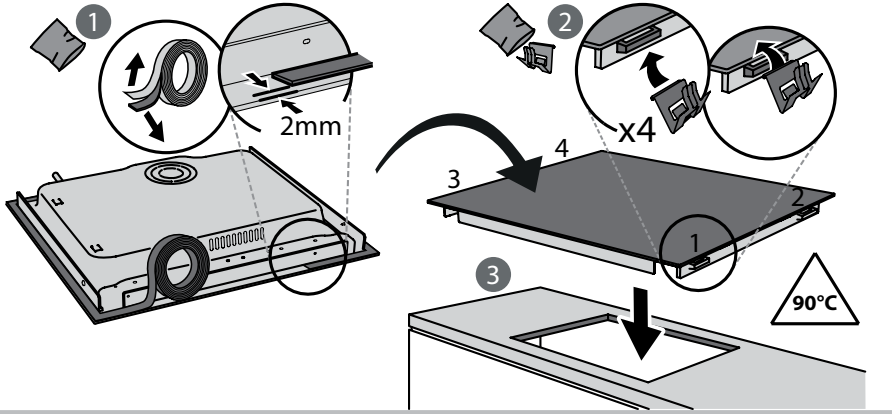
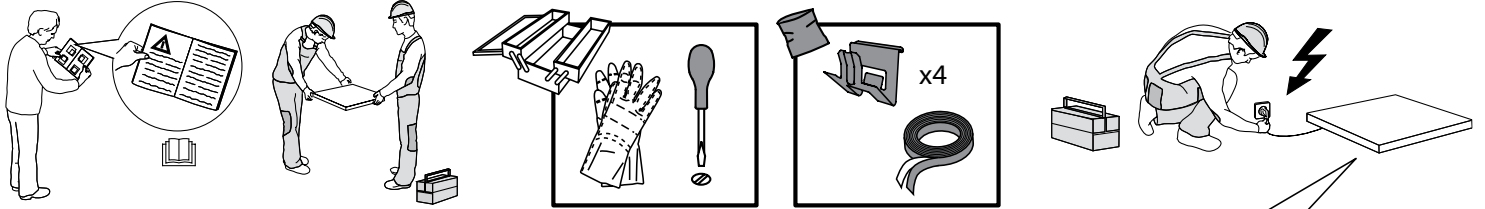

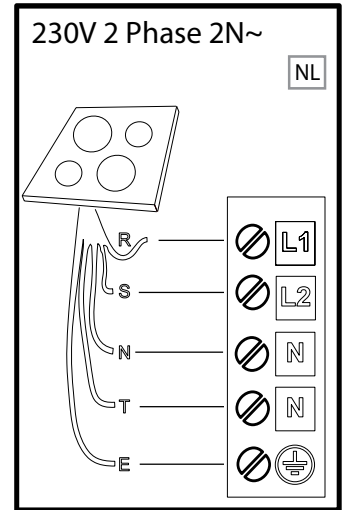
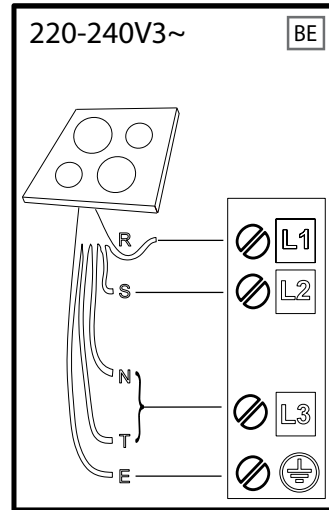
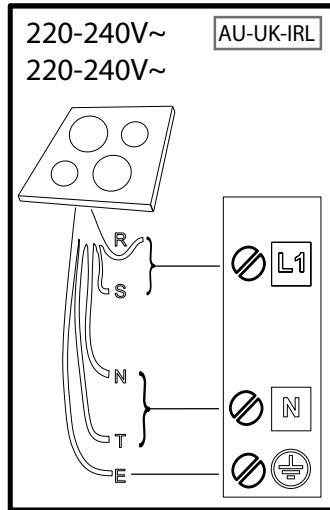
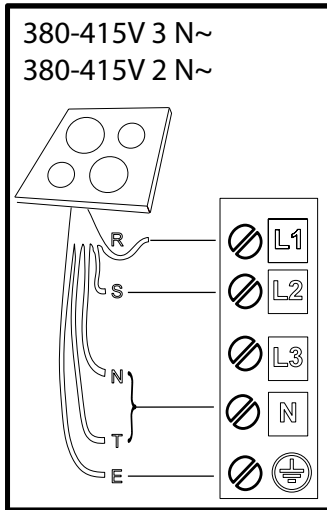

R

black-nero-negro-preto-μαύρος-must-melns-juodas-czarny-schwarz-noir-zwart-negru
чёрно-црн-črna-crno-черный-чорний-қара-černá-čierna-fekete-svart-musta-svart-sort
siyah-dubh

S

brown-marrone-marrón-marrom-каφέ-pruun-brūns-rudas-brązowy-braunen-brun-bruin
maro-кафяв-браон-rjava-smeđ-коричневый-коричневий-қоңыр-hnědý-hnedý-barna
brunt-ruskea-brunt-brun-kahverengi-donn

T

blue (gray)-blu (grigio)-azul (gris)-azul (cinza)-μπλε (γκρι)-sinine (hall)-zila (pelēka)
mėlyna(pilkas)-niebieski (szary)-blau (grau)-bleu (gris)-blauw (grijs)-albastru (gri)
синьо (сиво)-плава (сива)-modro(sivo)-plava (siva)-синий (серый)-синий (сірий)
көк (сұр)-modrý (šedá)-modrý(sivá)-kék (szürke)-blá (grá)-sininen (harmaa)-blá (grá)
blåt (gråt)-mavi (gri)-gorm (liath)



=

E

yellow/green-giallo/verde-amarillo/verde-amarelo/verdekίτρινο/πράσινο-kollane/roheline
dzeltens/zaļš-geltona/žalia-žółty/zielony-gelb/grün-jaune/vert-geel/groen-galben/verde
жълто/зелено-жудо/зелена-rumeno/zeleno-žuto/zelena-желтый/зеленый-gul/grønn
жовтий/зелений-жасыл/сары-žlutá/zelená-žltá/zelená-sárga/zöld-keltainen/vihreä
gul/grön-gul/grøn-sarı/yeşil-buı/glas

N

blue-blu-azul-azul-μπλε-sinine-zila-mėlyna-niebieski-blau-bleu-blauw-albastru-синьо
плава-modro-plava-синий-синий-көк-modrý-modrý-kék-blá-sininen-blá-blåt-mavi-gorm



400011503572