

AKP 671/IX

12NC: 857767101500

EAN code: 8003437935848

Whirlpool

SENSING THE DIFFERENCE

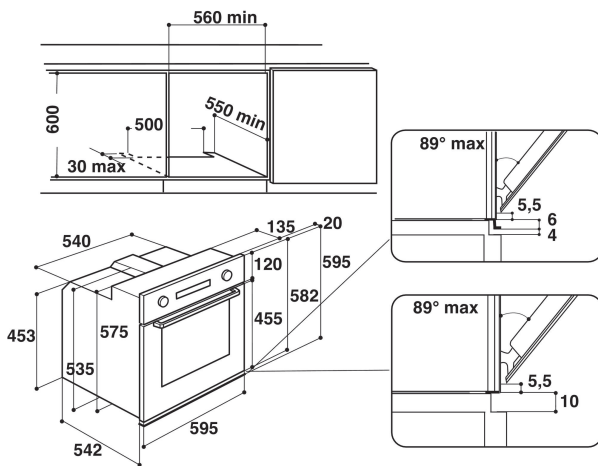

MAIN FEATURES

Product group	Oven
Commercial code	AKP 671/IX
Main colour of product	Inox
Construction type	Built-in
Type of control	Mechanical and electronic
Type of control setting and signalling devices	-
Are any hobs controls integrated?	Ne
Which kind of hobs can be controlled?	-
Automatic programmes	Ano
Current (A)	16
Voltage (V)	230
Frequency (Hz)	50
Length of Electrical Supply Cord (cm)	120
Plug type	Ne
Depth with open door 90 degree (mm)	-
Height of the product	595
Width of the product	595
Depth of the product	564
Minimum niche height	0
Minimum niche width	0
Niche depth	0
Net weight (kg)	33
Usable volume (of cavity)	60
Noise level (dB(A) re 1 pW)	0
Integrated Cleaning system	Ne
Grids	1
Trays	3

TECHNICAL FEATURES

Timer	Programmable
Time control	Electronic
Time-setting options	Start and Stop
Safety device	-
Interior light	-
Number of interior lights	1
Position of interior lights	Rear
Oven guides	Grids
Probe	Ne

ENERGETICKÝ ŠTÍTEK

Energy input	Electric
Type of energy	Electricity
Energy efficiency class - cavity 1	A
Energy consumption conventional (kWh)	1.1
Energy consumption forced air convection (kWh)	0.79