

ADG 422

12NC: 851123910000

EAN code: 8003437220623



SENSING THE DIFFERENCE

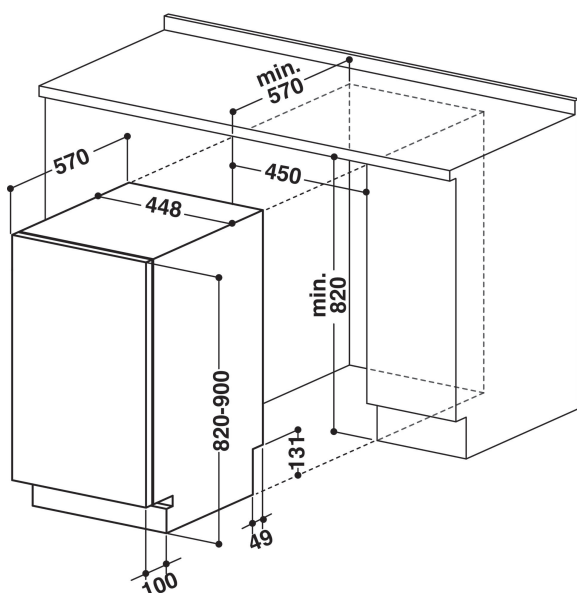

MAIN FEATURES

| | |
|--|----------------------|
| Construction type | Vstavaná |
| Installation type | Plne vstavaná |
| Type of control | Electronic |
| Type of control setting and signalling devices | - |
| Removable work top | N/A |
| Door decor panel | N/A |
| Main colour of product | Strieborná |
| Connection rating (W) | 1900 |
| Current (A) | 13 |
| Voltage (V) | 220-240 |
| Frequency (Hz) | 50 |
| Length of Electrical Supply Cord (cm) | 130 |
| Plug type | Schuko |
| Length inlet hose (cm) | 155 |
| Length outlet hose (cm) | 150 |
| Adjustable plinth | Nie |
| Height of removable worktop (mm) | 0 |
| Adjustable feet | Yes - all from front |
| Height of the product | 820 |
| Width of the product | 448 |
| Depth of the product | 550 |
| Depth with open door 90 degree (mm) | - |
| Minimum niche height | 820 |
| Maximum niche height | 900 |
| Minimum niche width | 450 |
| Maximum niche width | 600 |
| Niche depth | 570 |
| Net weight (kg) | 31.50 |
| Gross weight (kg) | 33.50 |

TECHNICAL FEATURES

| | |
|---|------------|
| Automatic programmes | Áno |
| Maximum temperature for water intake (°C) | 60 |
| Start delay options | Continuous |
| Start delay time max. (h) | 12 |
| Progress indicator | - |
| change to: | Nie |
| Salt light indicator | Áno |
| Rinse aid light indicator | Áno |
| Safety device | Áno |
| Adjustable upper basket | Áno |
| Largest loadable dish upper basket (cm) | 0 |
| Largest loadable dish lower basket (cm) | 0 |

ENERGETICKÝ ŠTÍTK

| | |
|--|------|
| Energy efficiency class - NEW (2010/30/EC) | A++ |
| Energy consumption annual (kWh/annum) - NEW (2010/30/EC) | 211 |
| Duration of the left-on mode - NEW (2010/30/EC) | 0 |
| Power consumption in left-on mode - NEW (2010/30/EC) | 5 |
| Power consumption in off-mode - NEW (2010/30/EC) | 0.50 |
| Water consumption annual (l/annum) - NEW (2010/30/EC) | 2520 |
| Noise level (dB(A) re 1 pW) | 45 |