

MN 212 IX HA

12NC: F096678

GTIN (EAN) code: 8007842966787

Hotpoint

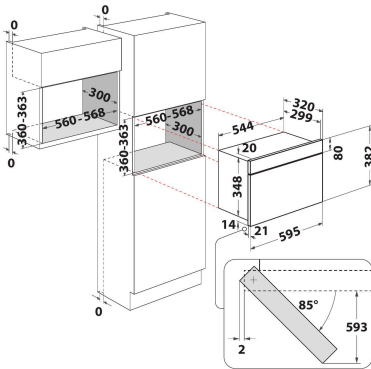

MAIN FEATURES

Product group	Microwave
Commercial code	MN 212 IX HA
Main colour of product	Stainless steel
Type of micro-wave oven	MW only
Construction type	Built-in
Type of control	Electronic
Type of control settings	LED
Additional cooking method Grill	No
Хрупкаво	No
Steam	Yes
Additional cooking method Fan cooking	No
Clock	Yes
Automatic programmes	No
Height of the product	382
Width of the product	595
Depth of the product	320
Minimum niche height	360
Minimum niche width	556
Niche depth	300
Net weight (kg)	21
Cavity capacity (l)	22
Turntable	Yes
Turntable diameter (mm)	250
Integrated Cleaning system	No

TECHNICAL FEATURES

Current (A)	10
Voltage (V)	230
Frequency (Hz)	50
Length of Electrical Supply Cord (cm)	135
Plug type	Schuko
Timer	Yes
Grill power (W)	0
Type of grill	N/A
Cavity material	Painted
Interior light	Yes
Additional cooking method Grill	No
Position of interior lights of the cavity	Right side

ENERGY LABEL

6th Sense / Dynamic Intelligence	No
Number of power levels	4
Maximum micro-wave power (W)	750
Размразяване на хляб	No
Размразяване	Yes
Старт	Yes