

HTU32X

12NC: F032592

GTIN (EAN) code: 8007842325928

Hotpoint

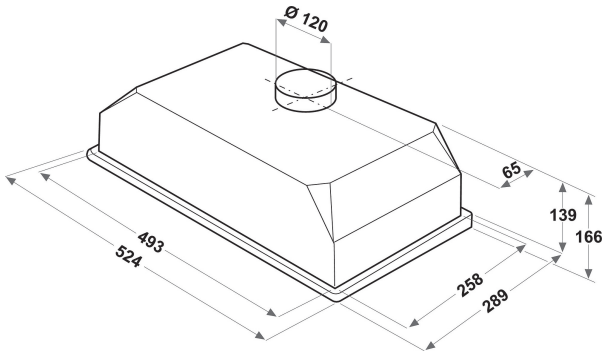

MAIN FEATURES

Product group	Hood
Colour body	Grey
Material body	Stainless steel
Colour chimney	-
Material chimney	-
Typology	Built-in/Built-under
Installation type	Built-in
Type of control	Mechanical
Type of control settings	-
Decor panel options	-
Motor location	Integrated motor in hood body
Operating Mode	Convertible
Electrical connection rating (W)	156
Current (A)	0,8
Voltage (V)	220-240
Frequency (Hz)	50/60
Length of Electrical Supply Cord (cm)	-
Plug type	No
Chimney height (mm)	-
Height of product, without chimney (mm)	0
Height of the product	166
Width of the product	524
Depth of the product	289
Minimum niche height	0
Minimum niche width	0
Niche depth	0
Net weight (kg)	4.4

TECHNICAL FEATURES

Type of manual control devices	Slider
Type of automatic control devices	-
Number of motors	1
Total power of the motors (W)	100
Number of speed settings: boost option availability	3
Boost presence	No
Maximum output air extraction (m ³ /h)	175
Boost position air extraction (m ³ /h)	0
Maximum output recirculating air (m ³ /h)	115
Boost position output recirculating (m ³ /h)	0
Light Control Type	On/Off
Number of lights	2
Type of lamps used	Halogen
Total power of the lamps (W)	56
Diameter of air outlet (mm)	120
No-return airflow flap	No
Grease filter material	Washable aluminium
Odour filter	Yes

PERFORMANCES

Sound power at min. speed (2010/30/EU)	48
Sound power at max. speed (2010/30/EU)	58
Noise level with boost position (dB(A) re 1 pW)	0