

AKM 516/JA

12NC: 857151638700

EAN code: -

Whirlpool

SENSING THE DIFFERENCE

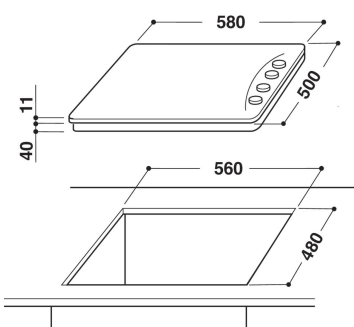

MAIN FEATURES

Product group	Hob
Construction type	Вбудована
Type of control	Mechanical
Type of control setting and signalling devices	N/A
Number of gas burners	4
Number of electric cooking zones	0
Number of electric plates	0
Number of radiant plates	0
Number of halogen plates	0
Number of induction plates	0
Number of electric warming zones	0
Location of control panel	Hob Lateral
Basic surface material	Enamelled
Main colour of product	Jasmine
Electrical connection rating (W)	0
Gas connection rating (W)	7300
Current (A)	0
Voltage (V)	230
Frequency (Hz)	50
Length of Electrical Supply Cord (cm)	0
Plug type	Hi
Gas connection	Cilindric
Width of the product	580
Height of the product	41
Depth of the product	500
Minimum niche height	30
Minimum niche width	560
Niche depth	480
Net weight (kg)	7.50
Automatic programmes	Hi

TECHNICAL FEATURES

Power on indicator	Hi
Plate on indicator	0
Type of regulation	Semirapid
Type of lid	Glass
Residual heat indicator	without
Main on/off switch	Hi
Safety device	Yes
Timer	Hi

ENERGY LABEL

Energy input

Gas