

ART 866/A+

12NC: 856426496000

EAN code: 8003437038099

Whirlpool

SENSING THE DIFFERENCE

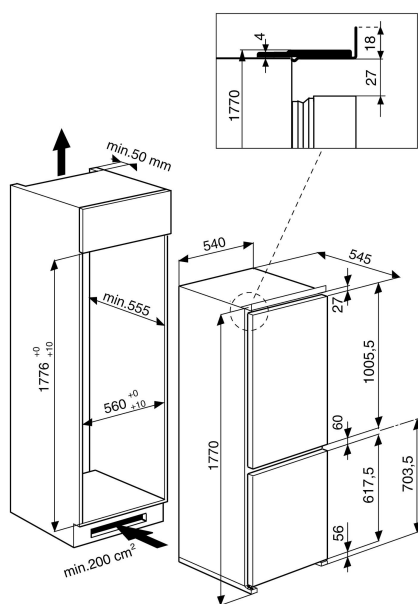

MAIN FEATURES

Product group	Kombinovaná chladnička
Installation type	Built-in
Type of control	Electronic
Construction type	Built-in
Main colour of product	White
Connection rating (W)	160
Current (A)	16
Voltage (V)	220-240
Frequency (Hz)	50
Number of compressors	1
Length of Electrical Supply Cord (cm)	245
Plug type	Schuko
Total unit net capacity (l)	265
Star Rating	4
Height of the product	0
Width of the product	540
Depth of the product	545
Maximum adjustability feet	0
Net weight (kg)	58

TECHNICAL FEATURES

Defrost process fridge section	Automatic
Defrost process freezer section	Manual
Fast cooling switch	Ne
Fast freezing function	Ano
Door opened indicator freezer	Ne
Temperature adjustable	-
Temperature adjustable freezer	Ano
Interior ventilator fridge section	Ano
Number of freezing drawers	3
Automatic motor-driven ice-maker	Ne
Number of shelves in fridge compartment	4
Material of the shelves	Glass With Profile
Thermometer fridge section	None
Thermometer freezer section	None
Number of temperature zones	1

ENERGETICKÝ ŠTÍTEK

Energy efficiency class - NEW (2010/30/EC)	A+
Energy consumption annual (kWh/annum) - NEW (2010/30/EC)	304
Refrigerator Net capacity (l) - NEW (2010/30/EC)	194
Freezer Net capacity (l) - NEW (2010/30/EC)	0
Freezing capacity (kg/24h) - NEW (2010/30/EC)	9
Climate class	T
Noise level (dB(A) re 1 pW)	37
Frost free system	Ne