

ACM 828/BA

12NC: 855782801030

GTIN (EAN) code: 8003437828058

Whirlpool

SENSING THE DIFFERENCE

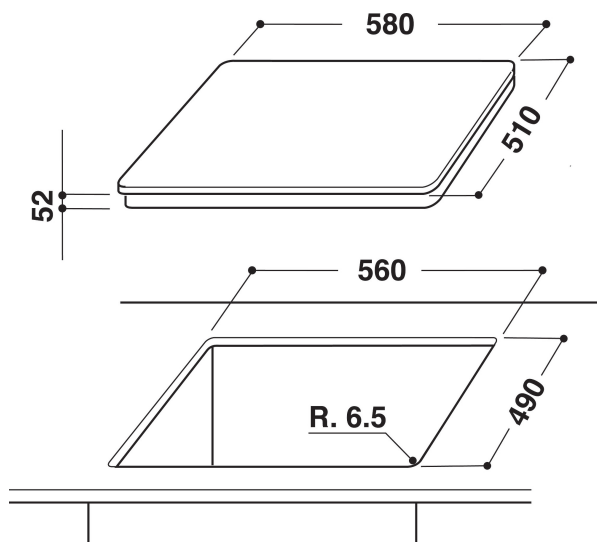
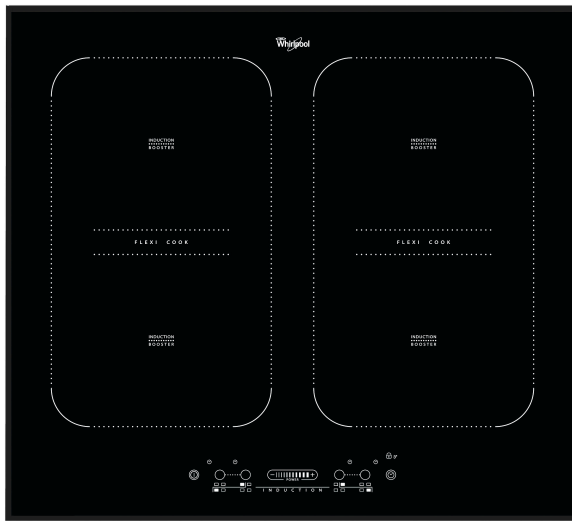

- 4 induction cooking zones
- FlexiCook
- Residual heat indicator
- Child lock
- On/Off Switch
- 60 cm hob
- Timer
- Slider touch control
- Black Glass Hob
- 4 Boosters
- 4 Plate on Indicator
- Total power declared: 7.2 kW
- Power on indicator
- Supply cord included
- Dimensions HxWxD: 56x580x510 mm
- Niche dimensions HxWxD: 60x560x490 mm
- Electrical Connection Rating: 7200 W

Whirlpool induction glass-ceramic hob - ACM 828/BA

4 induction rings. flexiCook zone technology, allowing you to combine multiple burners into a single cooking zone, for larger pots and pans. Intuitive slider, for effortless control of your appliance settings. This Whirlpool induction glass-ceramic Hob features: An elegant technology, that heats the pan, not the hob, reducing energy dispersion and providing perfect cooking results. Electric power supply.



Induction technology

Faster, energy-efficient cooking. Induction technology heats the pan, not the hob, reducing energy dispersion by 10%, and providing perfect cooking results.



FlexiCook

Flexibility and performance. FlexiCook provides flexible cooking space for pots and pans of any size.



Slider

Intuitive cooking. The intuitive touch-sensitive Slider allows you to control the power for each hob whilst the illuminated display shows you which cooking zones are currently being used.



Flexible Cooking

Automatic power settings. Select the cooking function on your touch display and your hob will automatically adjust the power level accordingly.



Front Controls

Complete control over your cooking. Easily accessible and genuinely intuitive, the controls are conveniently positioned on the front panel of your hob, providing a frictionless cooking experience.



Booster

Enjoy super fast boiling times with the Booster cooking zone.



Touch control

Cooking at the press of a button. Thanks to TouchControl, the precise control of your hobs is at your finger tips. The sensor power regulation does without the 10 phases on most dials and thus allows for simpler cleaning and care for your hob.

ACM 828/BA

12NC: 855782801030

GTIN (EAN) code: 8003437828058

Whirlpool

SENSING THE DIFFERENCE

MAIN FEATURES

Product group	Hob
Construction type	Built-in
Type of control	Electronic
Type of control settings	-
Number of gas burners	0
Number of electric cooking zones	4
Number of electric plates	0
Number of radiant plates	0
Number of halogen plates	0
Number of induction plates	4
Number of electric warming zones	0
Location of control panel	Front
Basic surface material	Glass
Main colour of product	Black
Electrical connection rating (W)	7200
Gas connection rating (W)	0
Gas type	N/A
Current (A)	31,3
Voltage (V)	230
Frequency (Hz)	50/60
Length of Electrical Supply Cord (cm)	0
Plug type	No
Gas connection	N/A
Width of the product	580
Height of the product	56
Depth of the product	510
Minimum niche height	30
Minimum niche width	560
Niche depth	490
Net weight (kg)	12.5
Automatic programmes	No

TECHNICAL FEATURES

Power on indicator	Yes
Number of indicators	4
Type of regulation	Stepless energy regulated
Type of lid	Without
Residual heat indicator	Separate
Main on/off switch	Yes
Safety device	-
Timer	Yes

PERFORMANCES

Energy input	Electric
--------------	----------