

ADG 422

12NC: 851123910000

EAN code: 8003437220623

Whirlpool

SENSING THE DIFFERENCE

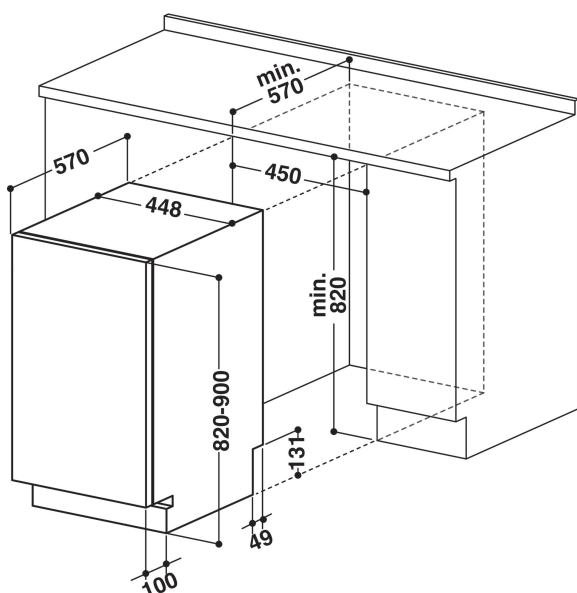

MAIN FEATURES

Construction type	Built-in
Installation type	Plne vestavná
Type of control	Electronic
Type of control setting and signalling devices	-
Removable work top	N/A
Door decor panel	N/A
Main colour of product	Stříbrná
Connection rating (W)	1900
Current (A)	13
Voltage (V)	220-240
Frequency (Hz)	50
Length of Electrical Supply Cord (cm)	130
Plug type	Schuko
Length inlet hose (cm)	155
Ledningslængde (cm)	150
Adjustable plinth	Ne
Height of removable worktop (mm)	0
Adjustable feet	Yes - all from front
Height of the product	820
Width of the product	448
Depth of the product	550
Depth with open door 90 degree (mm)	-
Minimum niche height	820
Maximum niche height	900
Minimum niche width	450
Maximum niche width	600
Niche depth	570
Net weight (kg)	31.50
Gross weight (kg)	33.50

TECHNICAL FEATURES

Automatic programmes	Ano
Maximum temperature for water intake (°C)	60
Start delay options	Continuous
Start delay time max. (h)	12
Progress indicator	-
Digital countdown indicator	Ne
Salt light indicator	Ano
Rinse aid light indicator	Ano
Safety device	Ano
Adjustable upper basket	Ano
Largest loadable dish upper basket (cm)	0
Largest loadable dish lower basket (cm)	0

ENERGETICKÝ ŠTÍTEK

Energy efficiency class - NEW (2010/30/EC)	A++
Energy consumption annual (kWh/annum) - NEW (2010/30/EC)	211
Duration of the left-on mode - NEW (2010/30/EC)	0
Power consumption in left-on mode - NEW (2010/30/EC)	5
Power consumption in off-mode - NEW (2010/30/EC)	0.50
Water consumption annual (l/annum) - NEW (2010/30/EC)	2520
Noise level (dB(A) re 1 pW)	45