

1. Plaque rapide Ø 180 - 2000 W
2. Plaque normale Ø 145 - 1000 W
3. Plaque rapide Ø 180 - 1500 W
4. Plaque normale Ø 145 - 1000 W
5. Bouton de commande plaque rapide Ø 180
6. Bouton de commande plaque normale Ø 145
7. Bouton de commande plaque rapide Ø 180
8. Bouton de commande plaque normale Ø 145
9. Voyant de fonctionnement des plaques électriques









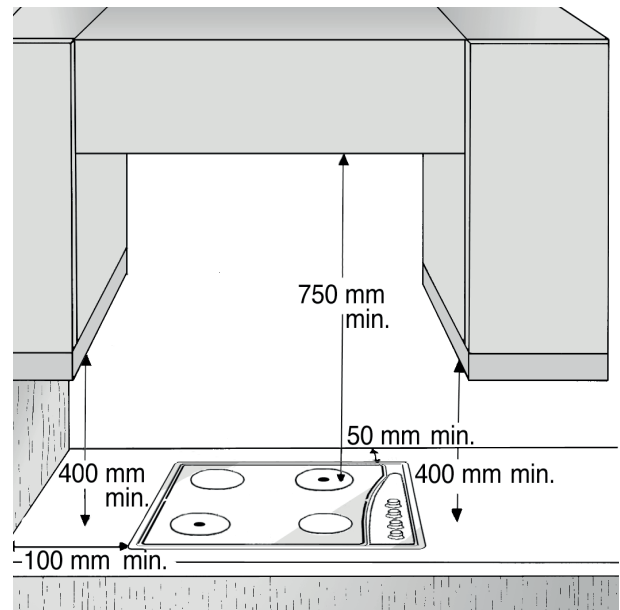
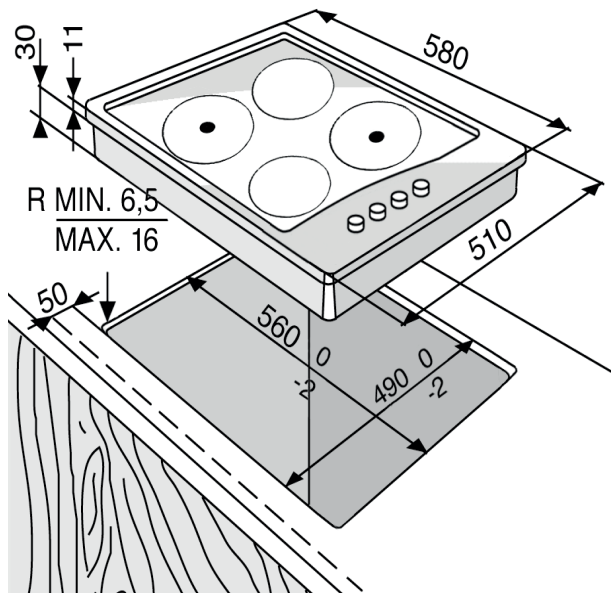





Fonctionnement des plaques électriques :

- Réglez le bouton sur les positions de 1 à 6, qui correspondent aux différentes températures.
- Pour éteindre la plaque, remettez le bouton sur la position « 0 ».

DIMENSIONS DE LA TABLE DE CUISSON ET DU PLAN DE TRAVAIL (mm)



REMARQUE : Si vous installez une hotte au-dessus du plan de cuisson, veuillez à respecter la distance indiquée dans le manuel d'utilisation de la hotte.

TENSION D'ALIMENTATION	CONDUCTEURS: NOMBRE ET DIMENSION	BRANCHEMENTS ÉLECTRIQUES												
230V ~ + 	3 x 2,5 mm ²	<table style="border: none;"> <tr><td>1</td><td>2</td><td>3</td><td></td></tr> <tr><td>○</td><td>○</td><td>○</td><td>○</td></tr> <tr><td>L</td><td></td><td>N</td><td></td></tr> </table>	1	2	3		○	○	○	○	L		N	
1	2	3												
○	○	○	○											
L		N												
230V 3 ~ + 	4 x 1,5 mm ²	<table style="border: none;"> <tr><td>1</td><td>2</td><td>3</td><td></td></tr> <tr><td>○</td><td>○</td><td>○</td><td>○</td></tr> <tr><td>L1</td><td>L2</td><td>L3</td><td></td></tr> </table>	1	2	3		○	○	○	○	L1	L2	L3	
1	2	3												
○	○	○	○											
L1	L2	L3												
400V 2N + 	4 x 1,5 mm ²	<table style="border: none;"> <tr><td>1</td><td>2</td><td>3</td><td></td></tr> <tr><td>○</td><td>○</td><td>○</td><td>○</td></tr> <tr><td>L1</td><td>L2</td><td>N</td><td></td></tr> </table>	1	2	3		○	○	○	○	L1	L2	N	
1	2	3												
○	○	○	○											
L1	L2	N												

TYPE: PLETP 230V~/400V 2N ~ 50Hz 6,0 kW

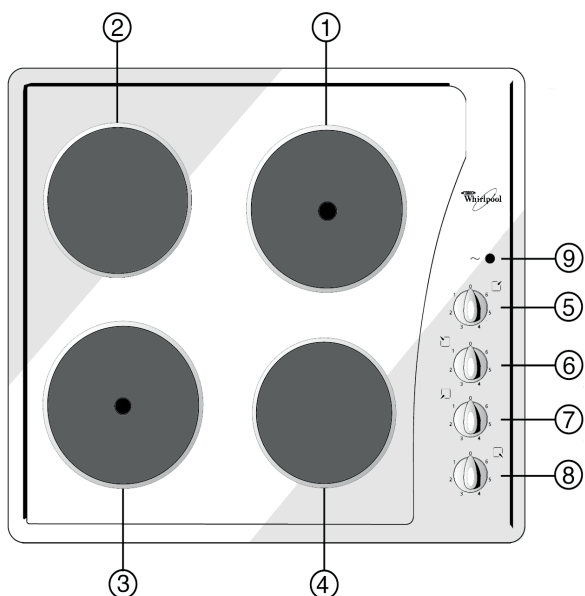

1. Rapid hotplate Ø 180 - 2000 W
2. Normal hotplate Ø 145 - 1000 W
3. Rapid hotplate Ø 180 - 1500 W
4. Normal hotplate Ø 145 - 1000 W
5. Rapid hotplate control knob Ø 180
6. Normal hotplate control knob Ø 145
7. Rapid hotplate control knob Ø 180
8. Normal hotplate control knob Ø 145
9. Hotplate operation lamp



Operation of electric hotplates :

- Set the knob to one of positions 1-6, which correspond to different temperatures.
- To switch off the hotplate, set the knob to position "0".

