

# AKZM 762/IX

12NC: 852576201000

GTIN (EAN) code: 8003437819865

Whirlpool

SENSING THE DIFFERENCE

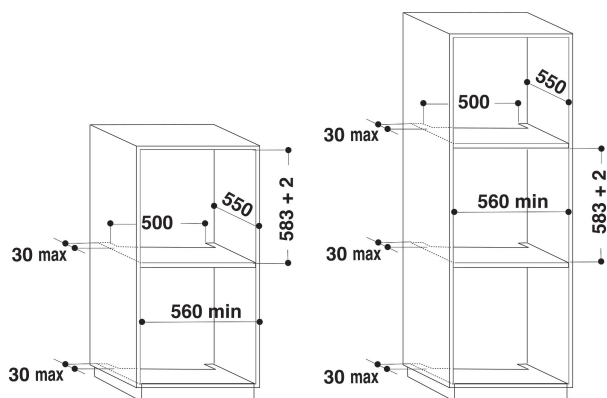

## MAIN FEATURES

Product group	Oven
Commercial code	AKZM 762/IX
Main colour of product	Nerez
Construction type	Built-in
Type of control	Mechanical and electronic
Type of control settings	-
Are any hobs controls integrated?	Ne
Which kind of hobs can be controlled?	-
Automatic programmes	Ano
Current (A)	16
Voltage (V)	220-240
Frequency (Hz)	50/60
Length of Electrical Supply Cord (cm)	90
Plug type	Ne
Depth with open door 90 degree (mm)	-
Height of the product	595
Width of the product	595
Depth of the product	564
Minimum niche height	0
Minimum niche width	0
Niche depth	0
Net weight (kg)	36.5
Usable volume (of cavity)	73
Integrated Cleaning system	Ne
Grids of the cavity	2
Trays	1

## TECHNICAL FEATURES

Timer	-
Time control	Electronic
Time-setting options	-
Safety device	-
Interior light	Ano
Number of interior lights of the cavity	1
Position of interior lights of the cavity	Rear
Oven guides of the cavity	Grids
Probe of the cavity	Ne

## ENERGETICKÝ ŠTÍTEK

Energy input	Electric
Type of energy of the cavity	Elektrický
Energy efficiency class - NEW (2010/30/EU)	A+
Energy consumption per cycle conventional - NEW (2010/30/EU)	0.91
Energy consumption per cycle forced air convection - NEW (2010/30/EU)	0.7