

ADG 6353 A+ PC FD

12NC: 854263501000

EAN code: 8003437240713



SENSING THE DIFFERENCE

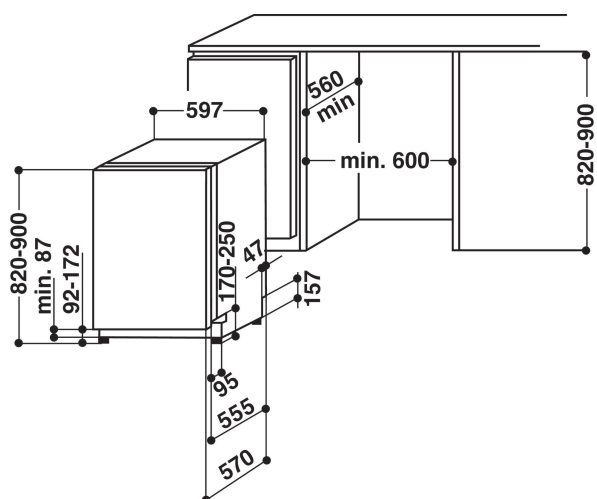

MAIN FEATURES

Construction type	Vstavaná
Installation type	Plne vstavaná
Type of control	Mechanical and electronic
Type of control setting and signalling devices	LED
Removable work top	Nie
Door decor panel	N/A
Main colour of product	Strieborná
Connection rating (W)	2200
Current (A)	10
Voltage (V)	220-230
Frequency (Hz)	50
Length of Electrical Supply Cord (cm)	150
Plug type	Schuko
Length inlet hose (cm)	150
Length outlet hose (cm)	200
Adjustable plinth	Nie
Height of removable worktop (mm)	0
Adjustable feet	Yes - all from front
Height of the product	820
Width of the product	597
Depth of the product	555
Depth with open door 90 degree (mm)	1150
Minimum niche height	820
Maximum niche height	900
Minimum niche width	600
Maximum niche width	600
Niche depth	560
Net weight (kg)	41
Gross weight (kg)	42.20

TECHNICAL FEATURES

Automatic programmes	Áno
Maximum temperature for water intake (°C)	60
Start delay options	One time fixed
Start delay time max. (h)	8
Progress indicator	Nie
change to:	Nie
Salt light indicator	Áno
Rinse aid light indicator	Áno
Safety device	N/A
Adjustable upper basket	Áno
Largest loadable dish upper basket (cm)	0
Largest loadable dish lower basket (cm)	0

ENERGETICKÝ ŠTÍTK

Energy efficiency class - NEW (2010/30/EC)	A+
Energy consumption annual (kWh/annum) - NEW (2010/30/EC)	295
Duration of the left-on mode - NEW (2010/30/EC)	3
Power consumption in left-on mode - NEW (2010/30/EC)	1.50
Power consumption in off-mode - NEW (2010/30/EC)	0.50
Water consumption annual (l/annum) - NEW (2010/30/EC)	3220
Noise level (dB(A) re 1 pW)	46