

ACM 795/BA

12NC: 859991007700

GTIN (EAN) code: 8003437825569

Whirlpool

SENSING THE DIFFERENCE

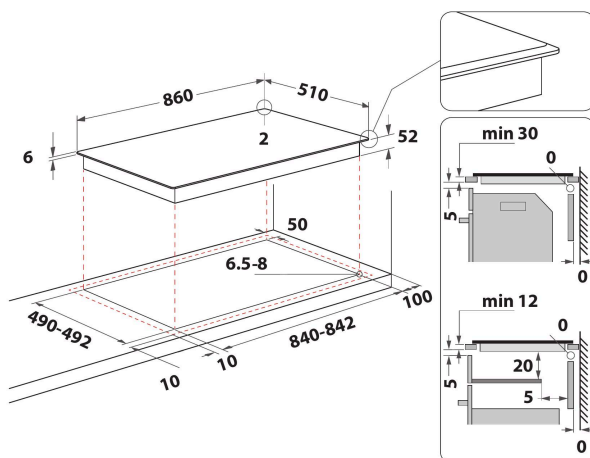
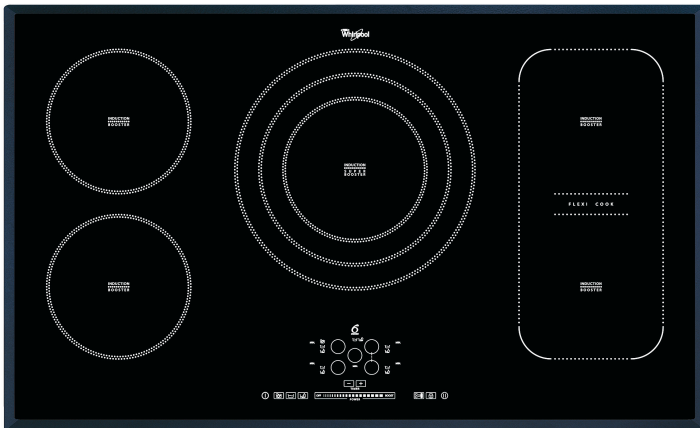

- 6TH Sense Technology
- 5 induction cooking zones
- FlexiCook
- Residual heat indicator
- Child lock
- On/Off Switch
- Simmering function
- Melting function
- 90 cm hob
- Timer
- Slider touch control
- Black Glass Hob
- 5 Boosters
- 1 Plate on Indicator
- Total power declared: 10.2 kW
- Power on indicator
- Supply cord included

Whirlpool induction glass-ceramic hob - ACM 795/BA

5 induction rings. flexiCook zone technology, allowing you to combine multiple burners into a single cooking zone, for larger pots and pans. Intuitive slider, for effortless control of your appliance settings. 6th SENSE technology, that allows you to automatically set the optimum temperature and power for simmering, melting or boiling, at the touch of a button. This Whirlpool induction glass-ceramic Hob features: An elegant technology, that heats the pan, not the hob, reducing energy dispersion and providing perfect cooking results.

Induction technology

Faster, energy-efficient cooking. Induction technology heats the pan, not the hob, reducing energy dispersion by 10%, and providing perfect cooking results.

FlexiCook

Flexibility and performance. FlexiCook provides flexible cooking space for pots and pans of any size.

Slider

Intuitive cooking. The intuitive touch-sensitive Slider allows you to control the power for each hob whilst the illuminated display shows you which cooking zones are currently being used.

6TH SENSE

Enjoy ideal cooking results. 6TH SENSE automatically sets the ideal temperature and power for simmering, melting, or boiling, at the touch of a button.

Flexible Cooking

Automatic power settings. Select the cooking function on your touch display and your hob will automatically adjust the power level accordingly.

Melting

Perfect low-heat cooking. The Melting function allows you to cook at very low temperatures, providing you with the ideal solution for melting chocolate, butter or for cooking light, delicate sauces.

Front Controls

Complete control over your cooking. Easily accessible and genuinely intuitive, the controls are conveniently positioned on the front panel of your hob, providing a frictionless cooking experience.

Booster

Enjoy super fast boiling times with the Booster cooking zone.

Boiling

Automatic Boiling Function

ACM 795/BA

12NC: 859991007700

GTIN (EAN) code: 8003437825569

Whirlpool

SENSING THE DIFFERENCE

MAIN FEATURES

Product group	Hob
Construction type	Built-in
Type of control	Electronic
Type of control settings	-
Number of gas burners	0
Number of electric cooking zones	5
Number of electric plates	0
Number of radiant plates	0
Number of halogen plates	0
Number of induction plates	5
Number of electric warming zones	0
Location of control panel	Front
Basic surface material	Glass
Main colour of product	Black
Electrical connection rating (W)	10200
Gas connection rating (W)	0
Gas type	N/A
Current (A)	26
Voltage (V)	230
Frequency (Hz)	50/60
Length of Electrical Supply Cord (cm)	120
Plug type	No
Gas connection	N/A
Width of the product	860
Height of the product	56
Depth of the product	510
Minimum niche height	30
Minimum niche width	840
Niche depth	490
Net weight (kg)	16.6
Automatic programmes	Yes

TECHNICAL FEATURES

Power on indicator	Yes
Number of indicators	1
Type of regulation	Stepless energy regulated
Type of lid	Without
Residual heat indicator	Separate
Main on/off switch	Yes
Safety device	-
Timer	Yes

PERFORMANCES

Energy input	Electric
--------------	----------