

ARG 590/3

12NC: 853459010000

GTIN (EAN) code: 8003437125911

Whirlpool

SENSING THE DIFFERENCE

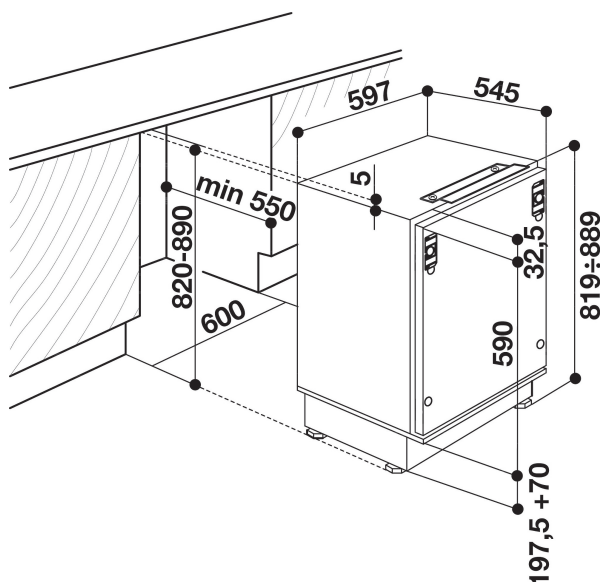

MAIN FEATURES

Grup produs	Combina frigorifica
Cod comercial	ARG 590/3
GTIN (EAN) code	8003437125911
Tipul constructiei	Incorporabil
Tipul instalatiei	Built-under
Tip control	Mecanic
Type of control settings	Mecanic
Culoare principala a produsului	Alb
Putere de conexie electrica (W)	100
Curent (A)	16
Voltaj (V)	220-240
Frecventa (Hz)	50
Length of Electrical Supply Cord (cm)	245
Tip priza	Schuko
Capacitate neta	129
Stele	4
Numarul sistemelor de racire independente	1
Inaltimea produsului	815
Dimensiune pachet produs	596
Adancimea produsului	545
Adancime cu usa deschisa la 90 de grade (mm)	-
Reglajul maxim al piciorului	0
Greutate neta (kg)	32
Balama usa	Usa reversibila

TECHNICAL FEATURES

Temperature adjustable	-
Semnal de alarma	Fara semnal
Sectiune frigider pentru procesul de decongelare	Automat
Fast cooling possibility	Fara
Ventilator interior al frigiderului	Fara
Rafturi pentru sticle	Fara
Usa care poate fi blocata	-
Numarul rafturilor din frigider	3
Numarul rafturilor reglabile in frigider	2
Materialul rafturilor	Sticla
Thermometer fridge section	Nici unul

ENERGY LABEL

Energy efficiency class - NEW (2010/30/EU)	A
Energy consumption annual (kWh/annum) - NEW (2010/30/EU)	230
Refrigerator Net capacity (l) - NEW (2010/30/EU)	111
Freezer Net capacity (l) - NEW (2010/30/EU)	18
Freezing capacity (kg/24h) - NEW (2010/30/EU)	2
Temperature rise time (h)	14
Clasa climatica	N
Nivel zgomot (dB(A) re 1pW)	38
Sistemul Frost Free	Fara
Temperatura ambientala maxima	0
Temperatura ambientala minima	0